

SR23 Series
Digital Controller
Instruction Manual
(Detailed version)

Servo output
(Positioning proportional control)

Thank you for purchasing the Shimaden SR23 Series Digital Controller. Check that the delivered product is the correct item you ordered. Do not begin operating this product until you have read and thoroughly understood the contents of this Instruction Manual (Detailed version).

SHIMADEN CO., LTD.

MSR023-E03-C
Dec. 2017

Request

Make sure that this Instruction Manual (Detailed version) is given to the final user of the device.

Keep this manual at the work site during operation of the SR23 Series.

Preface

This Instruction Manual describes the basic functions and how to use "Servo output" SR23 Series Controllers. For details on "2-input: 1-output/2-output" and "1-input: 1-output/2-output " refer to separate manuals.

This Instruction Manual is meant for those will be involved in the wiring, installation, operation and routine maintenance of the SR23 Series. This manual describes the handling, installation and wiring procedures for operation.

While using this device, you should always follow the instructions written in this manual.

For safety precautions and potential damage to equipment and/or facilities, additional instructions are indicated by the following headings.

Safety Precautions



Warning

The SR23 Series digital controllers are control instruments designed for industrial use to control temperature, humidity and other physical values.

It must not be used in any way that may adversely affect the safety, health or working conditions of those who come into contact with the effects of its use. When used, adequate and effective safety countermeasures must be provided at all times by the user. No warranty, express or implied, is valid when this device is used without the proper safety countermeasures.



Warning

- ◆ Before you start to use this device, install it in a control panel or the like and avoid touching the terminals.
- ◆ Do not open this device's case, and touch the boards or inside of the case with your hands or a conductor. The user should never repair or modify this device. Doing so might cause an accident that may result in death or serious bodily injury from electric shock.
- ◆ This servo output product is a position proportional controller for a control motor with limit switches. Do not use it for a motor without limit switches, or a motor with misaligned limit switches, because a failure or damage might happen to the motor.



Caution

To avoid damage to connected peripheral devices, facilities or the product itself due to malfunction of this device, safety countermeasures such as proper installation of the fuse or installation of overheating protection must be taken before use. No warranty, express or implied, is valid in the case of use resulting in an accident without having taken the proper safety countermeasures.

- ◆ The warning mark on the plate affixed on the casing of this device warns you not to touch charged parts while this device is powered ON. Doing so might cause an electric shock.
- ◆ A means for turning the power OFF such as switch or a breaker must be installed on the external power circuit connected to the power terminal on this device.
Fasten the switch or breaker at a position where it can be easily operated by the operator, and indicate that it is a means for powering this device OFF
- ◆ This device does not have a built-in fuse. Install a fuse that conforms to the following rating in the power circuit connected to the power terminal.
Fuse rating/characteristics: 250 VAC 1.0A/medium lagged or lagged type
- ◆ When wiring this device, tighten the terminal connections firmly.
- ◆ Use the device with the power voltage and frequency within their rated ranges.
- ◆ Do not apply a voltage or current outside of the input rating to the input terminal.
Doing so might shorten the service life of this device or cause it to malfunction.
- ◆ The voltage and current of the load connected to the output terminal should be within the rated range.
Exceeding this range may cause the temperature to rise which might shorten the service life of this device or cause it to malfunction.
- ◆ This device is provided with ventilation holes for heat to escape. Prevent metal objects or other foreign matter from entering these ventilation holes as this may cause this device to malfunction. Do not block these ventilation holes or allow dirt and dust to stick to these holes. Temperature buildup or insulation failure might shorten the service life of this device or cause it to malfunction.
- ◆ Repeated tolerance tests on voltage, noise, surge, etc. may cause this device to deteriorate.
- ◆ Never remodel this device or use it a prohibited manner.
- ◆ To ensure safe and proper use of this device, and to maintain its reliability, observe the precautions described in this manual.
- ◆ Do not operate the keys on the front panel of this device with a hard or sharp-tipped object. Be sure to operate the keys with your fingertips.
- ◆ When cleaning this device, do not use paint thinner or other solvents. Wipe gently with a soft, dry cloth.
- ◆ It takes 30 minutes to display the correct temperature after applying power to the digital controller. (Therefore, turn the power on more than 30 minutes prior to the operation.)

Check before use

This device has been fully checked for quality assurance before shipment from the factory. However, you are requested to make sure that there are no errors, damages or shortages in the delivered items by confirming the model code, external appearance of the device and the number of accessories.

Confirmation of model codes

Referring to the table below check the model codes affixed to the case of the product to check if the respective codes indicate what was specified when you ordered the product.

Checking accessories

Make sure that your product package has all of the following items

Standard accessories

- (1) Instruction Manual (A3 size paper ×4)
- (2) Mounting fixture (w/ 2 screws)
- (3) Terminal cover
- (4) Unit decal

Optional accessories

- (1) Terminal resistor (when the RS-485 communication option is selected)

Options (sold separately)

The following table shows the options available for this product.

Model Name	Model No.	Specification
Infrared Communication Adapter	S5004	USB 1.1
Shunt resistor	QCS002	250Ω±0.1%
Relay Unit	AP2MC	Converts open collector output to 2-point contact.
SV No. Selector	KA251	BIN code, switchable between SV1 to SV10

Setup tool "Parameter Assistant" /USB driver can be downloadable FREE from the Shimaden website shown as below.

■ Servo Output specification

Item	Code	Specification		
1. Series	SR23-	96 x 96 mm DIN size, high-performance digital controller		
2. Basic functions	MS	Universal-input, 1-input servo output, 3 event outputs		
3. Control Output *1	Y	Contact, rating: 240V AC 2A, CR absorber built-in		
	R	Contact, rating: 240V AC 2A		
4. Control Output 2	N-	None		
5. Remote Setting Input	Standard	06	0 to 10 V DC, Input resistance: approx. 500 k Ω	Non-insulated input
		04	4 to 20 mA DC, Receiving resistance: 250 Ω	
	05	1 to 5 V DC, Input resistance: approx.500 k Ω		
	Insulated input	Standard	14	4 to 20 mA DC, Receiving resistance 250 Ω
			15	1 to 5 V DC, Input resistance: approx.500 k Ω
			16	0 to 10 V DC, Input resistance: approx.500 k Ω
0			None	
6. Analog Output 1	Standard	3	0 to 10 mV DC, Output resistance: 10 Ω	
		4	4 to 20 mA DC, Load resistance: max.300 Ω	
		6	0 to 10 V DC, Load current: max. 2 mA	
		0	None	
7. Analog Output 2/Sensor Power Supply	Standard	3	0 to 10 mV DC, Output resistance: 10 Ω	
		4	4 to 20 mA DC, Load resistance: max.300 Ω	
		6	0 to 10 V DC, Load current: max.2 mA .	
		8	Sensor power supply 24 V DC 25mA	
8. External Input /Output control signals (DI/DO) *2	Standard	0	4 DI, 5 DO (SV No. switching not available)	
		1	10 DI, 9 DO (SV No. switching available)	
9. Communication function	Standard	0	None	
		5	RS-485	SHIMADEN protocol / MODBUS (ASCII / RTU) protocol
		7	RS-232C	
10. Remarks	Standard	0	Standard firmware	
		1-9	Customized firmware	
		A-Z		

*1 Y: This must be selected when directly controlling the motor.

R: This must be selected when controlling the motor through auxiliary relay, PLC or the like.

*2 When switching the SV No. by DI, 10 points of DI (CODE 1) are required.

Contents

1	INSTALLATION & WIRING	1
1-1	Installation Site	1
1-2	External Dimensions and Panel Cutout	1
1-3	Mounting.....	2
1-4	Rear Terminal Arrangement Diagrams	3
1-5	Wiring	5
	(1) Precautions for wiring	5
	(2) Connection example.....	6
2	NAMES & FUNCTIONS OF PARTS ON FRONT PANEL	7
3	BASIC OPERATIONS	11
3-1	Power ON.....	11
3-2	Switching LCD Screen Display and Moving the Cursor.....	12
	(1) Switching the screen display.....	12
3-3	Changing and Registering Data.....	13
	(1) Entering numerical values.....	13
	(2) Selecting setup items.....	14
4	CONTROL FUNCTION BLOCK DIAGRAMS	15
4-1	Servo output (with/without feedback).....	15
5	SETUP	17
5-1	Parameter Setup Procedure.....	17
6	OUTPUT SPECIFICATION & KEY LOCK	19
6-1	Confirming the Output Specification	19
6-2	Releasing the Key Lock.....	20
	(1) Key lock screen display	20
	(2) Releasing the key lock	20
7	INPUT SETTINGS	21
7-1	Infrared Communication	21
7-2	Measuring Range	22
	(1) Range setting.....	22
	(2) Range scaling	23

7-3	Unit.....	26
7-4	Decimal Point Position.....	26
	(1) Decimal point position	26
	(2) Switching the lowest digit past the decimal point	27
7-5	Cold Junction Compensation.....	28
	(1) Thermocouple cold junction compensation	28
8	I/O AUXILIARY SETTINGS.....	29
8-1	PV Compensation Value	29
	(1) PV bias	29
	(2) PV filter	29
	(3) PV slope	29
8-2	Square Root Extraction Operation.....	30
	(1) Enabling the square root extraction operation.....	30
	(2) Low cut	30
8-3	Ten-Segment Linearizer Approximation	31
	(1) Enabling ten-segment linearizer approximation	31
	(2) Setting input points	31
8-4	Compensating Analog Output	33
9	SV VALUE & REMOTE SV VALUE	35
9-1	Setting the SV Value	35
	(1) SV limiter	35
	(2) Set value (SV)	35
9-2	Setting the Remote SV Value.....	36
	(1) Monitoring the remote SV.....	36
	(2) Remote tracking	36
	(3) Remote mode.....	37
9-3	Setting the Remote SV Compensation Value.....	38
	(1) Remote ratio	38
	(2) Remote bias	39
	(3) Remote filter	39
	(4) Remote scale.....	40
9-4	Setting the Remote PID No. and Square Root Extraction Operation.....	41
	(1) Setting the remote PID No.....	41
	(2) Enabling remote square root extraction operation function	41
	(3) Low cut	41
9-5	Setting the Ramp.....	42
	(1) Ramp value	42
	(2) Ramp unit time	42
	(3) Ramp ratio	43
	(4) Executing ramp control.....	43

10	PID SETTING	45
10-1	Proportional Band (P)	45
10-2	Integral Time (I)	45
10-3	Derivative time (D).....	46
10-4	Manual Reset (MR)	46
10-5	Action Hysteresis (DF).....	47
10-6	Set Value Function (SF)	47
10-7	Output Limit Value (OUT1L to OUT1H)	48
10-8	Zone PID	49
	(1) Selecting Zone PID	49
	(2) Zone hysteresis.....	50
	(3) PID zone	50
10-9	Auto Tuning Point.....	51
11	EVENT & DO SETTING	53
11-1	Monitor Screens	53
	(1) DO monitor.....	53
	(2) Logic monitor	53
11-2	EVENT/DO Action	53
	(1) Output characteristics	55
	(2) Hysteresis	56
	(3) Delay time	56
	(4) Inhibit action.....	57
	(5) Event action at inhibit.....	57
11-3	Event Logic Operations	58
	(1) Logic operation mode (Log MD)	58
	(2) Assigning logic operation input (SRC1, SRC2).....	58
	(3) Logic operation input logic (Gate1, Gate2)	59
11-4	Timers/Counters	59
	(1) Timer time	59
	(2) Counter	60
	(3) Assigning input (SRC).....	60
	(4) Mode (Log MD)	60
12	OPTION SETTING (DI, AO, COM)	61
12-1	DI.....	61
	(1) DI monitor screen.....	61
	(2) Selecting DI action	61
12-2	Analog Output.....	63
	(1) Analog output type	63
	(2) Scaling analog output	63

12-3	Communication	64
	(1) Setting communication	64
	(2) Communication mode (COM).....	65
13	SERVO SETUP.....	67
13-1	Overview of Setup Procedure.....	67
13-2	Control Output (Servo Output).....	68
	(1) Action characteristics.....	68
	(2) Output at standby	68
	(3) Output at input error	69
	(4) Output at feedback potentiometer error.....	69
	(5) Rate-of-change limiter	70
13-3	Externally Switching Servo Preset Value.....	71
	(1) Mechanism and action of external switching.....	71
	(2) Setting Servo preset value	72
13-4	Setting Servo Operations	72
	(1) Setting Servo feedback	72
	(2) Setting Servo Dead Band.....	73
	(3) Setting motor timing.....	73
	(4) Setting Servo action on start-up	74
13-5	Servo Adjustment	75
	(1) Points for ZERO/SPAN adjustment and operation	75
	(2) ZERO/SPAN automatic adjustment.....	77
	(3) ZERO/SPAN manual adjustment	79
	(4) Adjustment of Dead Band (DB)	81
13-6	Servo Functions.....	82
	(1) Priority of actions at Servo output.....	82
	(2) MAN actions at servo output	82
	(3) Interrelation between assignment of preset output and control action	82
	(4) Output limiter	82
	(5) Servo Action	83
	(6) Interrelation between Dead Band (DB) and hysteresis	85
14	KEY LOCK SETTING.....	87
14-1	Setting Key Lock.....	87
	(1) Displaying the key lock screen	87
	(2) Key lock.....	87
15	MONITORING, EXECUTING & STOPPING OPERATION.....	89
15-1	Flow of Basic Screen.....	89
	(1) Control output (OUT1/Posi).....	89
	(2) Output with preset value (Preset1 to 7).....	90

15-2	Operations in Basic Screen	91
	(1) Switching the SV No.	91
	(2) Output monitor screen	91
16	OPERATIONS DURING CONTROL.....	93
16-1	Monitoring Control	93
	(1) Basic screen	93
	(2) Output monitor	93
16-2	Switching the Execution SV No.	93
16-3	Setting the Execution SV No.	94
16-4	Externally Switching the SV No.	95
16-5	Auto Tuning	96
	(1) Executing and Stopping Auto Tuning.....	96
	(2) Selecting the PID tuning mode	97
16-6	Self Tuning	97
16-7	Setting Control Output (MAN).....	98
	(1) Switching auto/manual.....	98
	(2) Output value.....	98
	(3) MAN key operations.....	99
16-8	Control Standby (STBY)	100
16-9	Pausing/Resuming Ramp Control (RAMP).....	101
16-10	Tuning Functions	102
	16-10-1 Auto tuning (AT)	103
	16-10-2 Self tuning.....	105
	(1) Self tuning: by step response (St).....	105
	(2) Self tuning: by hunting suppression (Hu)	107
17	ERROR DISPLAYS.....	109
17-1	Operation Check Abnormalities at Power ON.....	109
17-2	PV Input Abnormalities	109
17-3	REM Input Abnormalities	110
17-4	Feedback potentiometer error	110
18	LIST OF PARAMETERS.....	111
18-1	Basic Screen Group (group 0).....	111
18-2	Execution Screen Group (group 1)	111
18-3	SV Setup Screen Group (group 2).....	112
18-4	PID Screen Group (group 3).....	113
18-5	EVENT/DO Screen Group (group 4)	114
18-6	DI/Options Screen Group (group 5).....	116
18-7	Communication (group 5)	117

18-8	Control Output Screen Group (group 6)	118
18-9	Unit/Range Screen Group (group 7).....	119
18-10	Lock, etc Screen Group (group 8)	120
19	PARAMETER SETUP RECORD SHEETS	121
19-1	Product Model Code	121
19-2	SV Parameters	121
19-3	PID Parameters	122
19-4	EVENT/DO Parameters.....	123
19-5	DI/Options Parameters	124
19-6	Control Output Parameters.....	124
19-7	Unit Measuring Range Parameters	125
19-8	Lock, etc. Parameters.....	126
20	SPECIFICATIONS	127
20-1	Display.....	127
20-2	Setting	128
20-3	Input	129
20-4	Control.....	130
	(1) Control output	130
	(2) Servo output	130
20-5	Event Output	131
20-6	External Control Output (DO)	132
20-7	External Control Input (DI).....	132
20-8	Logic Operation Functions.....	133
20-9	Analog Output (option)	133
20-10	Sensor Power Supply (option).....	134
20-11	Communication (option)	135
20-12	Infrared Communication	136
20-13	General Specifications.....	136

This page left intentionally blank.

LCD Flow Chart

The following figure shows how to progress through the LCD screen hierarchy on this device.

- Standard screen Screens that are always displayed
- Non-standard screen Screens that are displayed depending on options/setup values.

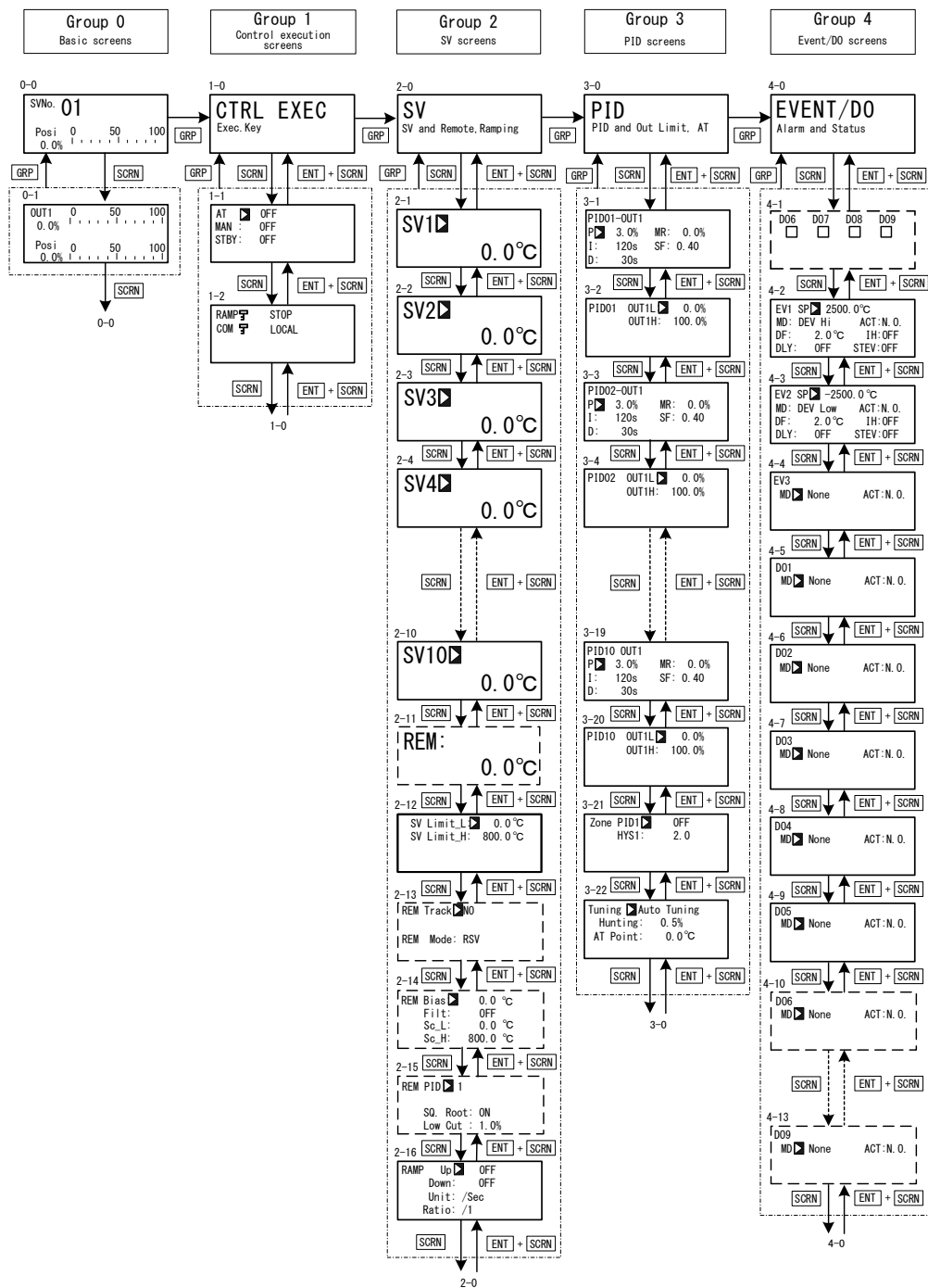

When the **DISP** key is pressed at a screen other than the 0-0 basic screen, the 0-0 basic screen is returned to.

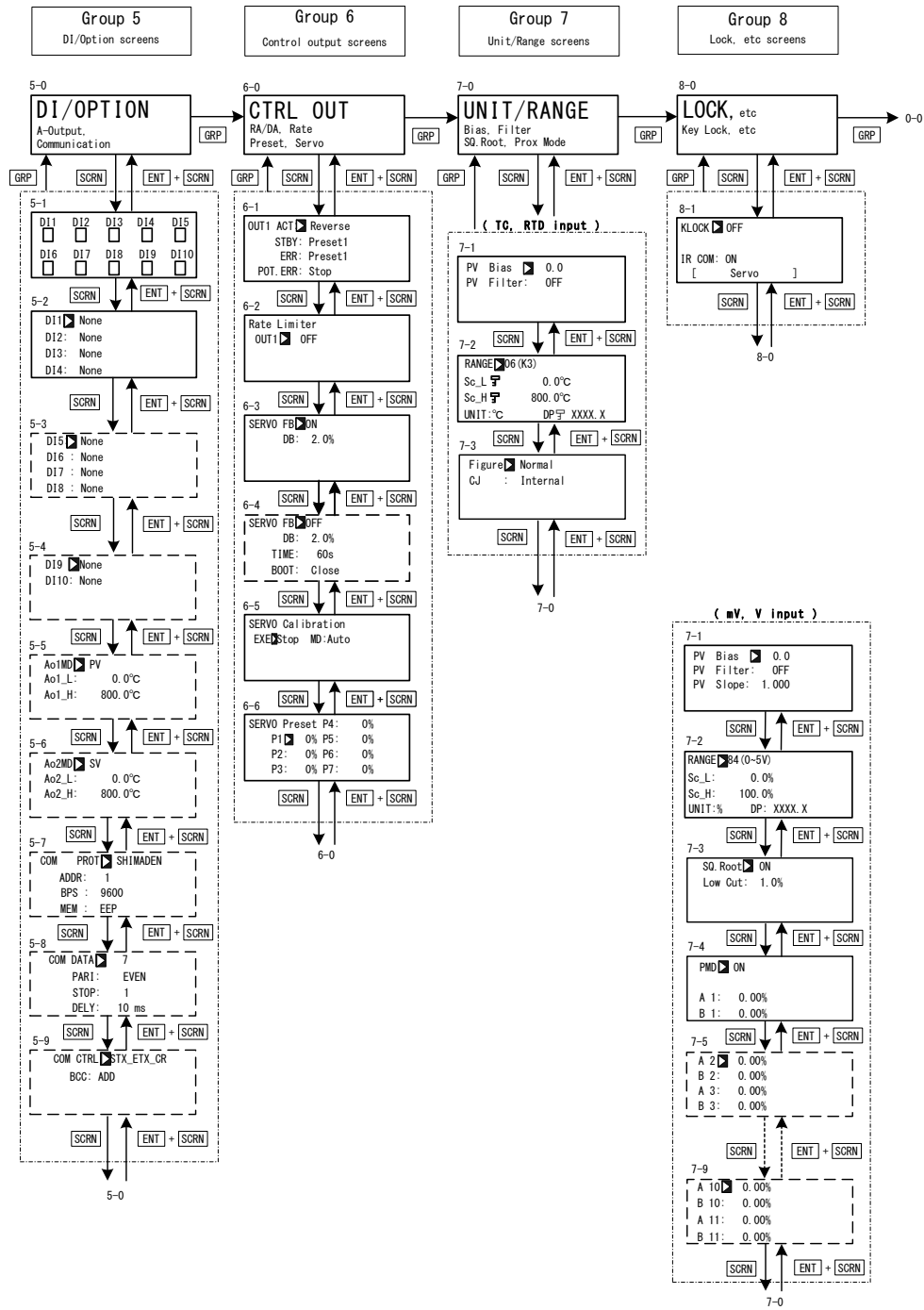

This page left intentionally blank.

1 INSTALLATION & WIRING

1-1 Installation Site



Caution

Do not use this device in the following sites. Doing so might result in malfunction or damage to this device and in some cases cause fire and/or dangerous situations.

- ◆ Locations that are filled with or generate inflammable gas, corrosive gas, dirt and dust, smoke, etc.
- ◆ Locations that are subject to water droplets, direct sunlight or strong radiated heat from other equipment
- ◆ Locations where the ambient temperature falls below -10°C or rises above 50°C
- ◆ Locations where dew condensation forms and the humidity reaches 90% or more
- ◆ Near equipment that generates high-frequency noise
- ◆ Near heavy current circuits or locations likely to be subject to inductive interference
- ◆ Locations subject to strong vibration and impact
- ◆ Locations exceeding an elevation of 2000 m

1-2 External Dimensions and Panel Cutout

■ External dimensions

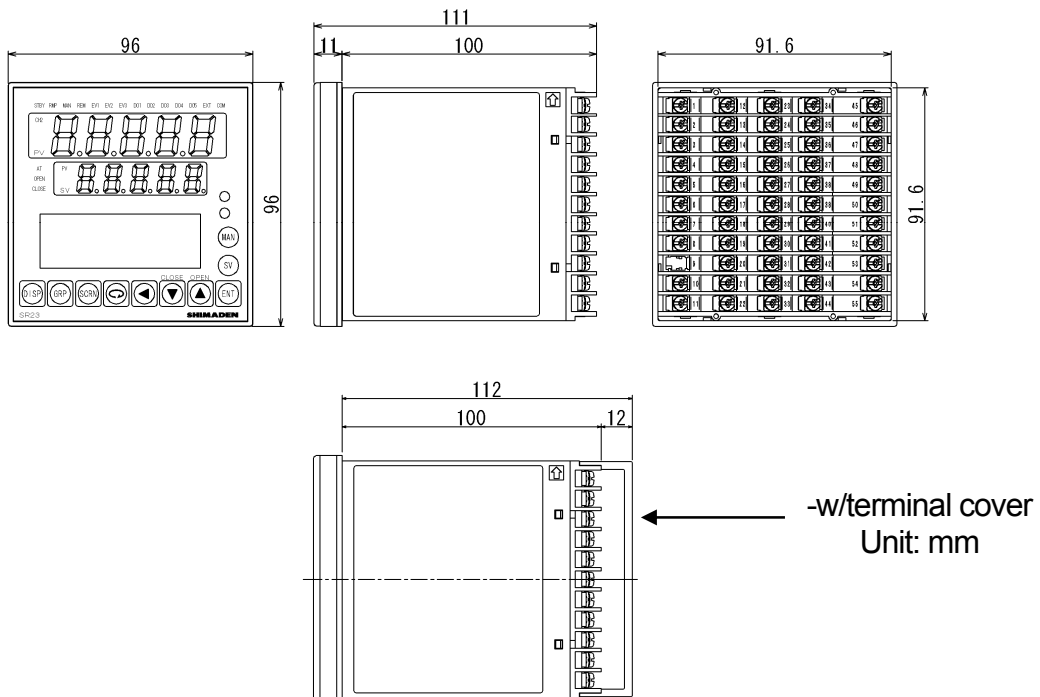

■ Panel cutout

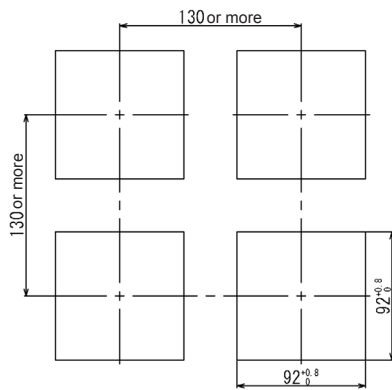

Unit: mm

1-3 Mounting



Caution

To ensure safety and maintain the functions of this device, do not disassemble this device.
If this device must be disassembled for replacement or repair, contact your dealer.

Follow the procedure below to mount this device on a panel.

1. Drill mounting holes referring to the panel cutout dimensions described in the previous section.
The applicable thickness of the mounting panel is 1.0 to 8.0 mm.
2. Press this device into the panel from the front of the panel.
3. Insert the mounting fixtures at the top and bottom of this device, and tighten the screws from behind to fasten the device in place.
4. Over-tightening the screws may deform or damage the device housing.
Take care not to tighten the screws too tight.
5. After completing wiring after installation, attach the terminal cover.

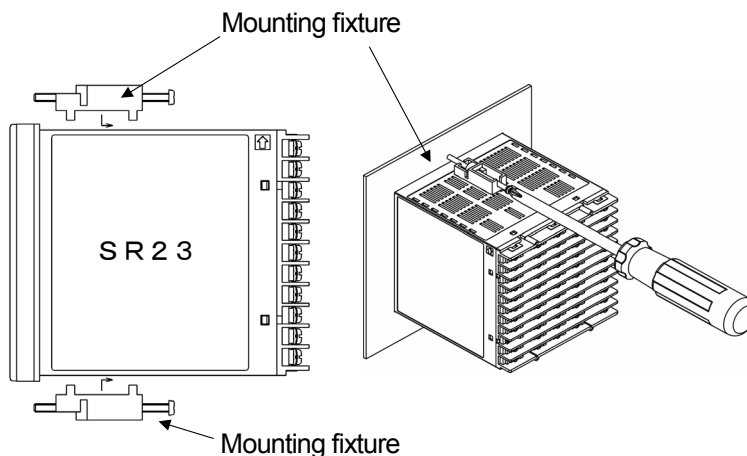

1-4 Rear Terminal Arrangement Diagrams

■ Contact output model

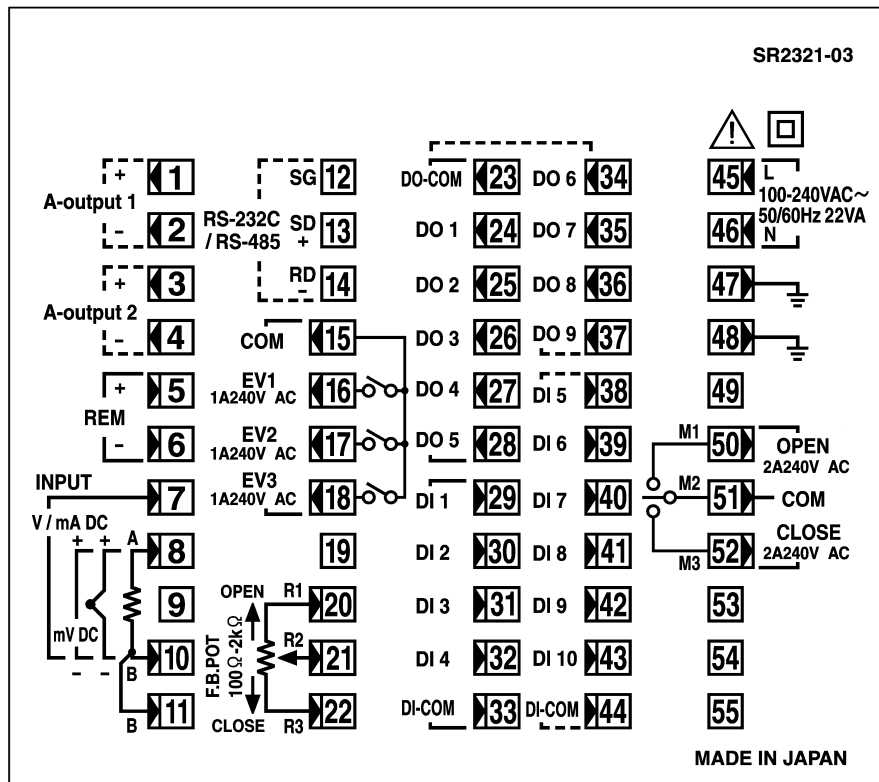

Terminal No.	Symbol	Description	
1	+	Analog output 1 (option)	
2	-		
3	+	Analog output 2 or Sensor power supply (option)	
4	-		
5	+	Remote input	
6	-		
8	+	mV, Thermocouple input	PV input
10	-		
8	A	RTD input	
10	B		
11	B		
7	+	V, mA input	
10	-		
45	L	Power supply	
46	N		

Terminal No.	Symbol	Description
34	DO6	External control output DO
35	DO7	
36	DO8	Open collector output (option)
37	DO9	
38	DI5	External input DI5 to DI10 (option)
39	DI6	
40	DI7	
41	DI8	
42	DI9	
43	DI10	
44	COM	
12	SG	Communication function (option)
13	SD +	
14	RD -	
15	COM	Event output
16	EV1	
17	EV2	
18	EV3	

47		Grounding (internal shorting across terminals)	
48			
49		NC	
50	M1	Open	Control Output
51	M2	COM	
52	M3	Close	
53		NC	
54			
55			
23	COM	External control output DO (standard feature)	
24	DO1		Darlington output
25	DO2		
26	DO3		
27	DO4		Open collector output
28	DO5		
29	DI1	External control output DI (standard feature)	
30	DI2		
31	DI3		
32	DI4		
33	COM		

19		NC
20	R1	Feedback potentiometer input
21	R2	
22	R3	

A receiving resistor of 1/2W 250Ω 0.1% is attached across input terminals (7-10) for use for the 0 to 20 mA, and 4 to 20mA inputs.

1-5 Wiring

(1) Precautions for wiring



Caution

- ◆ To prevent electric shock, always turn off and disconnect this device from the power supply before starting wiring.
- ◆ Do not touch wired terminals or charged parts with your hands while the power is supplied.

Pay attention to the following points when performing wiring:

- ◆ Check that the wiring is free from mistakes according to "1-4 Rear Terminal Arrangement Diagrams."
- ◆ Use crimped terminals that accommodate an M3 screw and that have a width of 6.2 mm or less.
- ◆ For thermocouple input, use a compensation wire compatible with the type of thermocouple.
- ◆ For RTD input, the resistance of a single lead wire must be 10Ω or less and the three wires must have the same resistance.
- ◆ The input signal lead must not be passed along the same conduit or duct as that for high-voltage power lines.
- ◆ Shield wiring (single point grounding) is effective against static induction noise.
- ◆ Short interval twisted pair wiring is effective against electromagnetic induction noise.
- ◆ When wiring, use wire or cable (minimum 1 mm^2 cross-sectional area) of 600 V grade PVC insulated wire or equivalent wire having the same rating.
- ◆ For wiring the ground, ground the ground terminal with the earth resistance at less than 100Ω and with wire 2 mm^2 or thicker.
- ◆ Two earth terminals are provided, each connected internally. One is for the ground connection, and the other is for connecting the shield of the signal lead. Do not use the earth terminals for crossover wiring of the power system ground lead.
- ◆ If this device is considered as being susceptible to noise caused by the power supply, attach a noise filter to prevent abnormal functioning.
Install a noise filter onto a grounded panel, and make the wire connecting the noise filter output and the power supply terminal on this controller as short as possible.

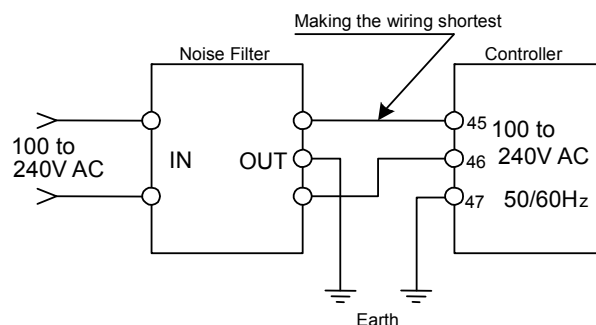

Recommended noise filter : RSEL-2003W from TDK

(2) Connection example

This instrument is designed to connect a control motor directly via the terminal M1, M2, and M3.

AC relay may have built-in CR absorber to protect its contact. DC relay use is recommended, because if AC relay is used as auxiliary relay, it cannot recover from magnetic excitation.

The terminal 47 and 48 are ground terminals.

One of these terminals should be connected to ground. Use another terminal in case the shield of the signal lead is running short.

Do not use the ground terminals for the power system ground lead.

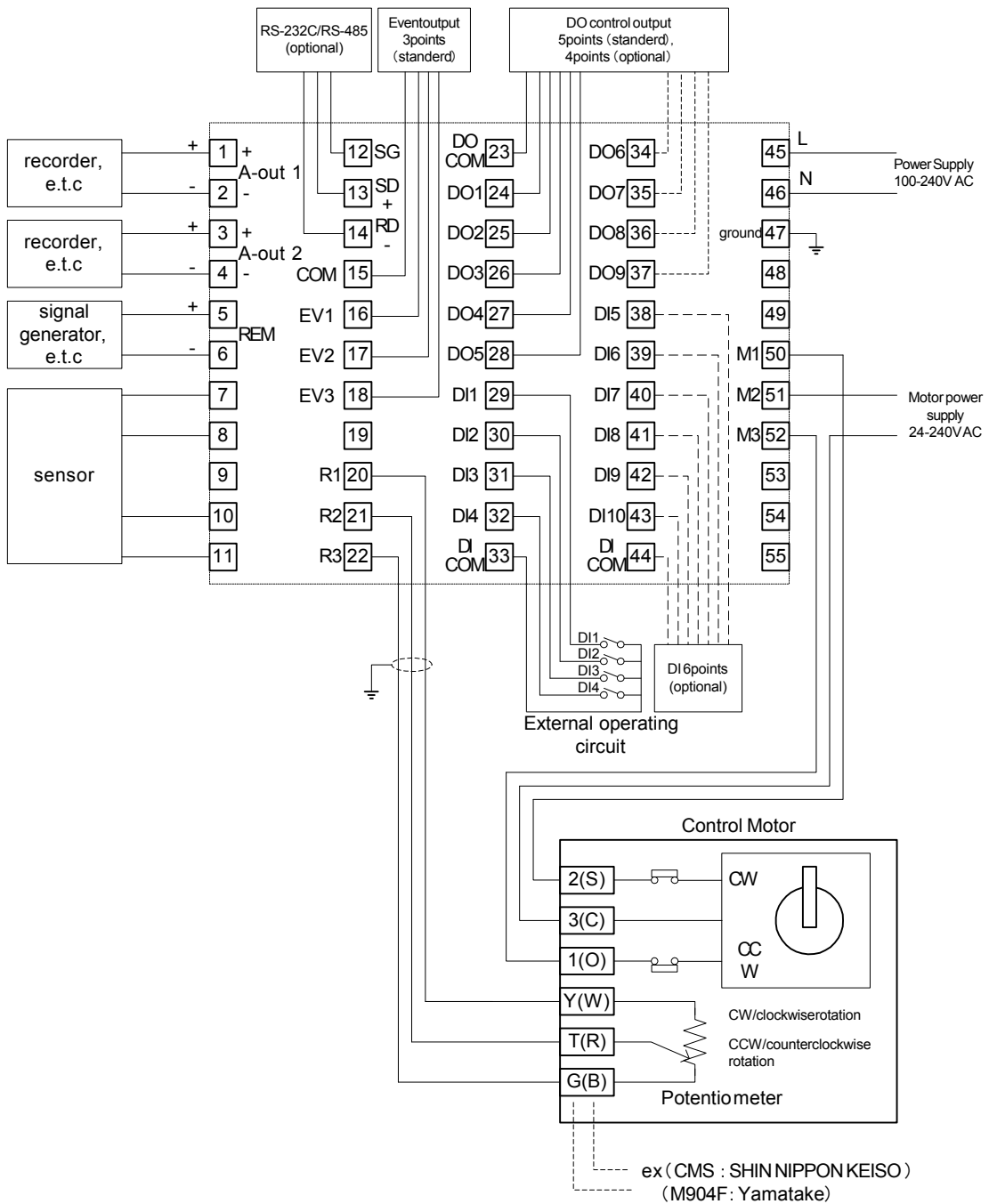

As for how to connect motor, refer to the manuals/documents of motors.

2 NAMES & FUNCTIONS OF PARTS ON FRONT PANEL

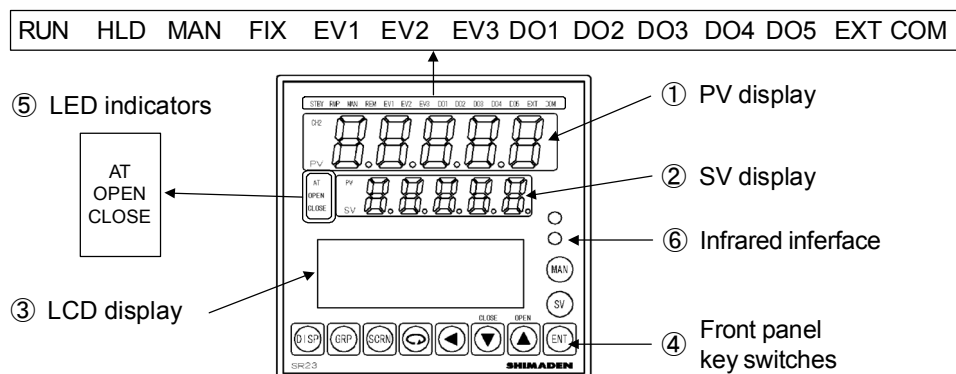

① PV display

Displays the measured value (PV value).

Displays an error message when an error (e.g. scale over) occurs.













② SV display

Displays the target set value (SV value).

③ LCD display (21 characters x 4 lines, max.)

SV No. display	Displays the current target setting value (SV) No..
Output (OUT) display	Displays the control output (OUT or Posi) value by a numerical value and a bar graph as a percentage (%).
Screen title display	Displays the screen group title in the respective screen group top screen.
Setup parameter display	Displays the parameters that can be selected and displayed by front key operation.

④ Front panel key switches

	(Display key)	Displays the basic screen.
	(Group key)	Changes the screen group. Or, returns to the screen group top screen.
	(Screen key)	Switches the parameter display screen in a screen group.
	(Parameter key)	Selects the parameter to set up or change. The parameter to be changed is indicated by the cursor (▶).
	(Shift key)	Moves the digit in set numerical values.
	(Down/CLOSE key)	Decrements parameters and numerical values during setup. When it is under the Manual mode, close output is set to on.
	(Up/OPEN key)	Increments parameters and numerical values during setup. When it is under the Manual mode, open output is set to on.
	(Entry key)	Registers data or parameter numerical values.
	(SV key)	Switches the execution SV No. in the basic screen. In screens other than the basic screen, the execution SV No. can be switched when the display is switched to the basic screen.
	(Manual key)	Used for manual output (MAN). Switches to the output monitor screen whichever screen is displayed. With the output monitor displayed, you can use the   keys to switch to manual output.

■Status lamps

STBY	green	Blinks when output is set to standby (STBY=ON) by control execution/standby.
RMP	green	Blinks during execution of ramp control, and lights while ramp control is paused.
MAN	green	Blinks when control output is set to manual operation (MAN).
REM	green	Lights when remote setting (REM) is set in SV No. selection.
EV1	orange	Lights during EV1 action.
EV2	orange	Lights during EV2 action.
EV3	orange	Lights during EV3 action.
DO1	orange	Lights during DO1 action.
DO2	orange	Lights during DO2 action.
DO3	orange	Lights during DO3 action.
DO4	orange	Lights during DO4 action.
DO5	orange	Lights during DO5 action.
EXT	green	Lights when external switch setting (EXT) is set when multi-SV No. selection (SV select) is switched to.
COM	green	Lights when communication (COM) mode is selected.
AT	green	Blinks during execution of auto tuning or lights during holding of auto tuning.
OPEN	green	Lights when open output is on, and goes out when it is OFF.
CLOSE	green	Lights when close output is on, and goes out when it is OFF.

This page left intentionally blank.

3 BASIC OPERATIONS

3-1 Power ON

When the power is turned ON, the basic screen is displayed after the initial screen is displayed on the LCD for about three seconds.

When the SR23 is powered ON for the first time, check on screen to make sure that this device is the one you ordered.

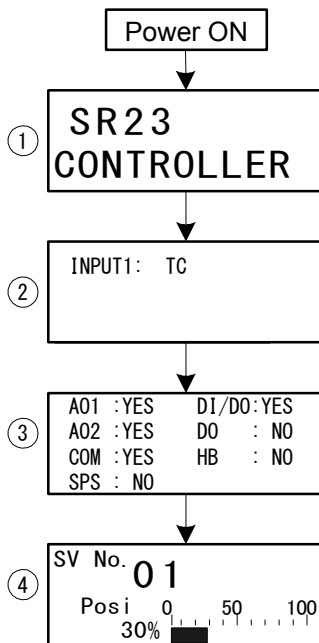

- ① The series name is displayed.
- ② The I/O type is displayed.
The figure shows a thermocouple (TC) set for Input 1.
- ③ The installation status of option functions is displayed.
The figure shows that Analog Output 1, Analog Output 2 and the communication function are installed (YES), the sensor power supply is not installed (NO), DI (10 points) and DO (9 points) are installed (YES), and DO 13 points and the heater break alarm are not installed (NO).
- ④ Basic screen (Monitor Group top screen)
This is a screen example of “with feedback” specification, and shows that the position of SV No.1 is outputting at 30%.

The details displayed on screen vary according to specifications, or according to preset function specifications.

The basic screen is the "SV No., output value, and position display screen.

Note

- ◆ The actually installed numbers for external DI or DO can be confirmed with the above ③ screen.

LCD Display		Actual numbers	
DI/DO	DO	DI	DO
NO	NO	4	5
YES	NO	10	9

3-2 Switching LCD Screen Display and Moving the Cursor

(1) Switching the screen display

For details on moving between screens, see "LCD Flow Chart" in the preface.

The operation screens of this device are configured so that screens are displayed in order from the most frequently used screen in regular use.

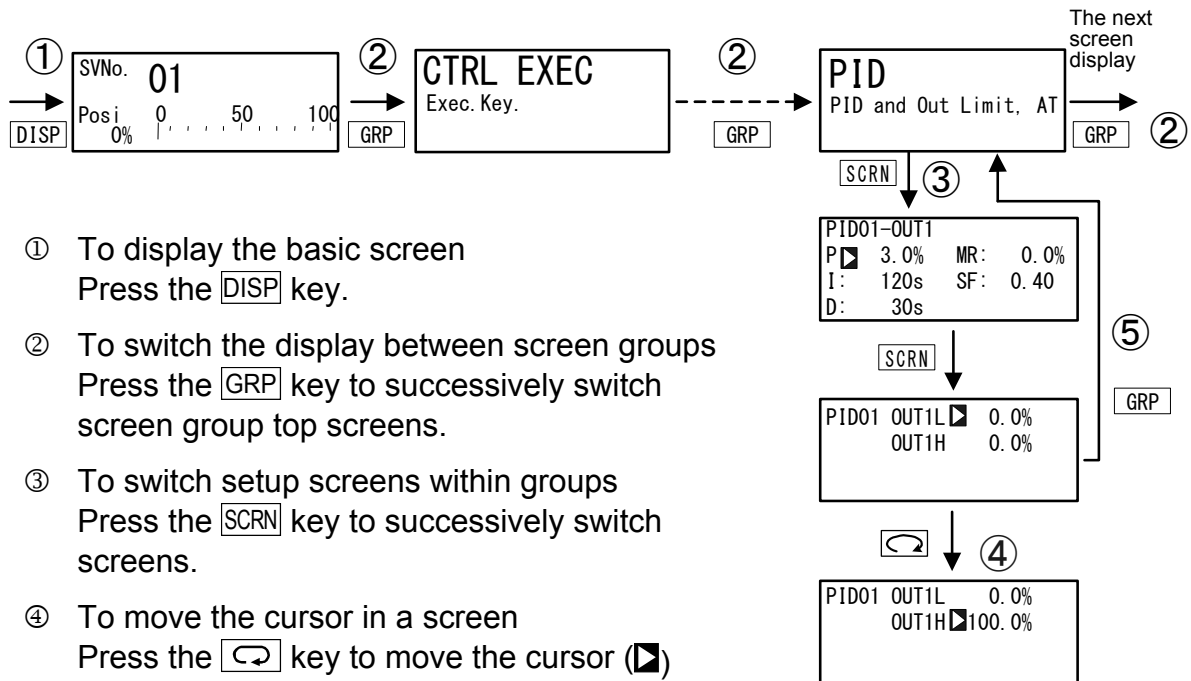









- ① To display the basic screen
Press the **DISP** key.
- ② To switch the display between screen groups
Press the **GRP** key to successively switch screen group top screens.
- ③ To switch setup screens within groups
Press the **SCRN** key to successively switch screens.
- ④ To move the cursor in a screen
Press the **↔** key to move the cursor (▣ blinking) when there are two or more parameters in the same screen.
- ⑤ To display the top screen
Press the **GRP** key in a respective parameter setup screen other than the basic screen group to switch to the top screen of a screen group.

3-3 Changing and Registering Data

Basically, set up and change parameters while confirming the LCD screen display.

(1) Entering numerical values

1. When there are two or more parameters, press the  key to move the cursor () to the parameter to be changed.
2. Press the  or ,  keys. The smallest digit of the numerical value blinks.
3. Press the  key again. Move the blinking section in the numerical value to the digit to be changed, and change the value using the  or  key.
4. Press the  key. The numerical value is fixed and registered, and stops blinking.



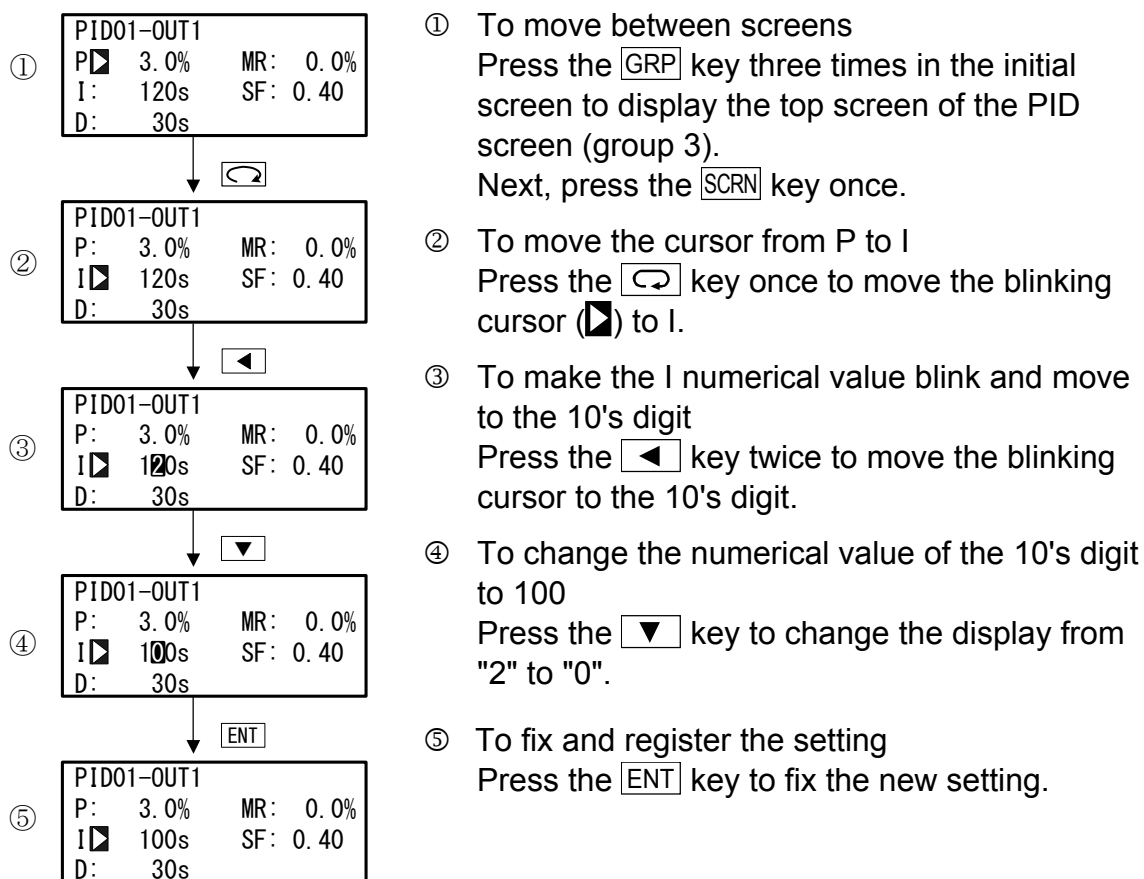

■ Changing a numerical value setting (example)

The following shows the procedure for changing the value of PID parameter I to 100 s.



(2) Selecting setup items

The settings of parameters marked by a  key mark cannot be changed.

1. When there are two or more parameters, press the  key to move the cursor () to the parameter to be changed.
2. Change the parameter settings by the  or  key, check the setting, and press the  key to fix and register settings. The character stops blinking.

■Selecting a parameter (example)

The following shows the procedure for changing control output to manual.

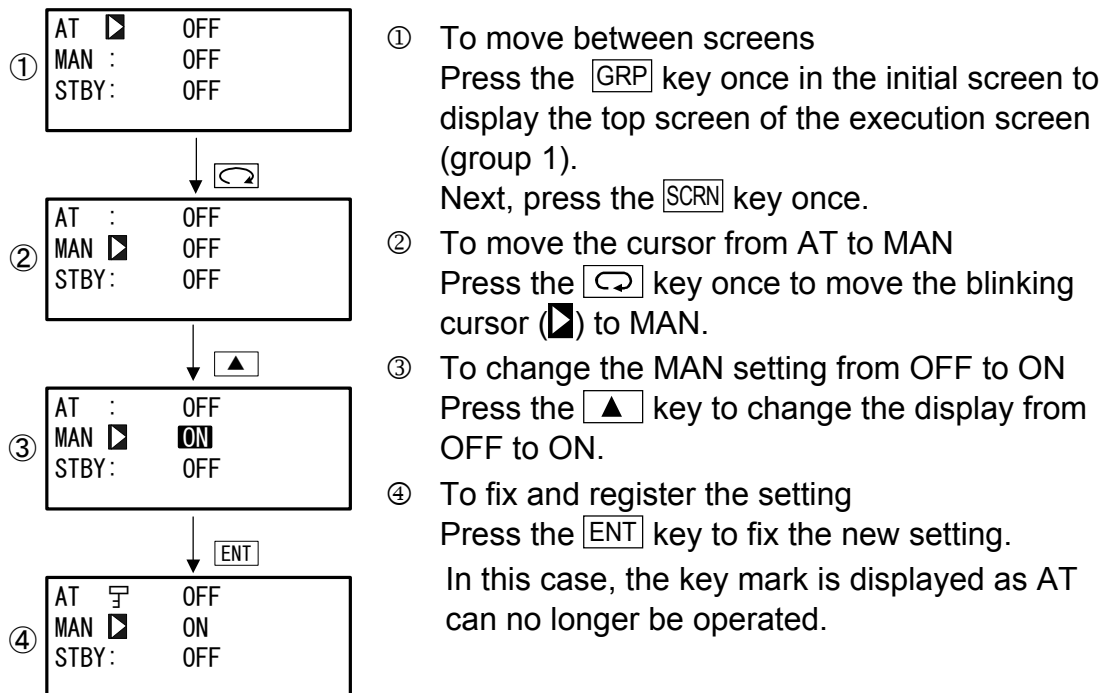

4 CONTROL FUNCTION BLOCK DIAGRAMS

4-1 Servo output (with/without feedback)

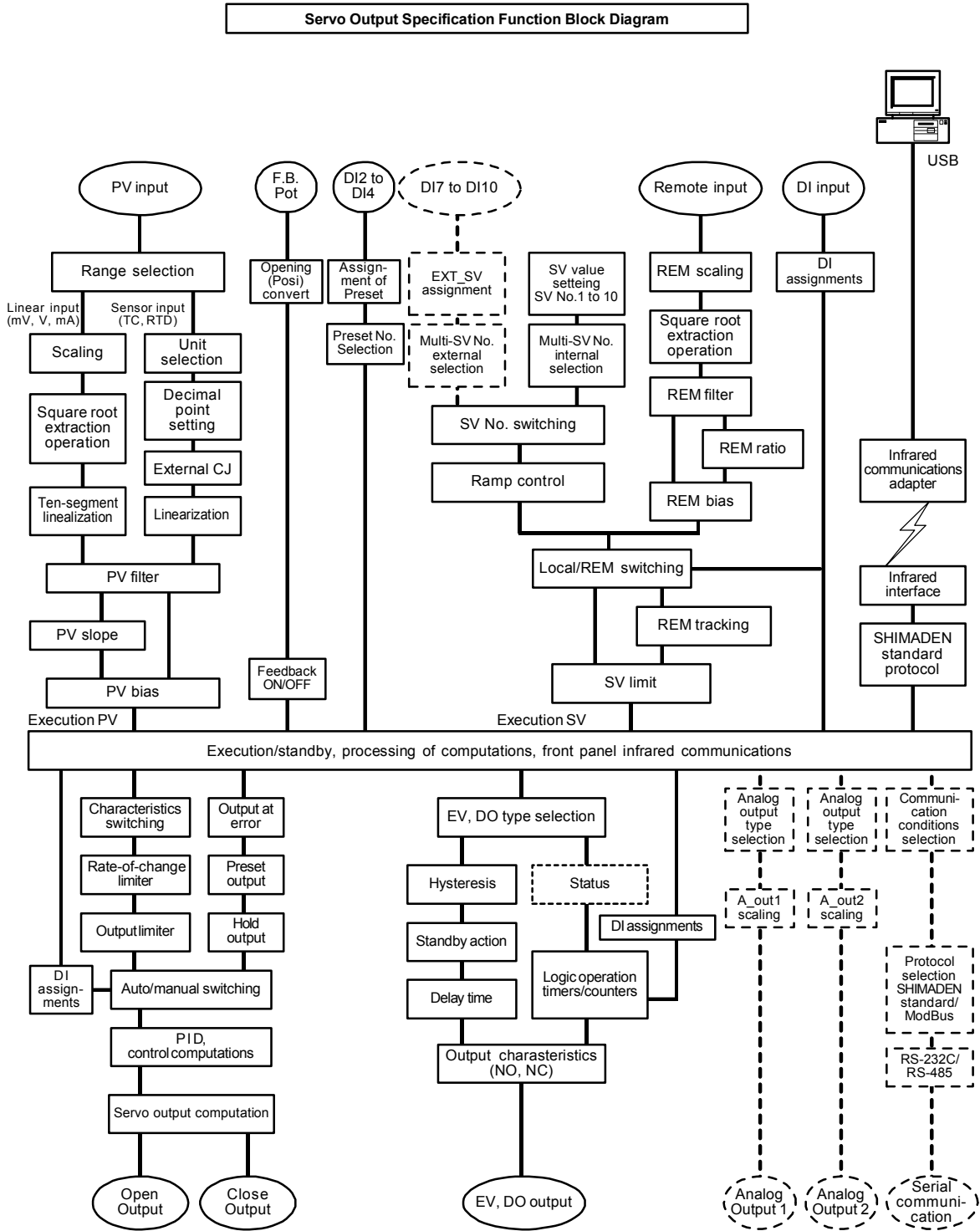

This page left intentionally blank.

5 SETUP

5-1 Parameter Setup Procedure

Follow the procedure below to set up this device or change device settings when you use this device for the first time, change the operation parameters during use, or the control target device has been changed, for example.

Caution

With some operations, when you initialize this device, all parameter settings return to their factory defaults.
Before you initialize this device, note down and retain settings as required.

It is assumed that experienced personnel familiar with basic operation of this device will set up this device.

Users other than device manufacturers should thoroughly familiarize themselves with the functions to be used before they start to operate or set up this device.

Basic operations and setup of this device are described in detail from Chapter 6 onwards by each screen group.

Some screens and parameters are not displayed when option functions are not added on or when option functions are not selected.

For an overview of operation screens and how to move between screens, see "LCD Flow Chart" in the preface. For an overview of setup parameters, see "18 List of Parameters."

Set up parameters in the order shown below.

1. Confirm the Output Specification and Release the Key Lock.
Perform this as necessary.
For details, see "Chapter 6."
2. Input Settings.
For details, see "Chapter 7."
3. I/O Auxiliary Settings.
For details, see "Chapter 8."
4. Set up the SV Value and Remove SV Value.
For details, see "Chapter 9."
5. PID Settings.
For details, see "Chapter 10."
6. EVENT/DO Settings.
For details, see "Chapter 11."
7. Option Settings (DI, AO, HB, COM).
For details, see "Chapter 12."

8. Servo Functions Settings

After basic parameters are set or changed, set servo relating parameters.
For details, see "Chapter 13".

9. Key Lock Setting.

After parameters including option functions are set or changed, set the key lock as necessary to prevent inadvertent operation.
For details, see "Chapter 14."

10. Monitoring, Executing & Stopping operation.

For details, see "Chapter 15."

11. Operations During Control.

For details, see "Chapter 16."

6 OUTPUT SPECIFICATION & KEY LOCK

Perform the following as necessary.

6-1 Confirming the Output Specification

The output specification is displayed at the bottom row of the key lock, setting screen (No.8-1).

To call up the LOCK, etc. screen group (group 8) from the basic screen, press the **[GRP]** key.

Press the **[SCRN]** key in the LOCK, etc. screen group to switch to the screens for making and changing setups.

The following is an example of screen transitions with “Feedback on”.

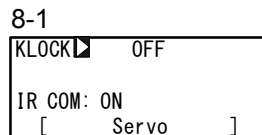
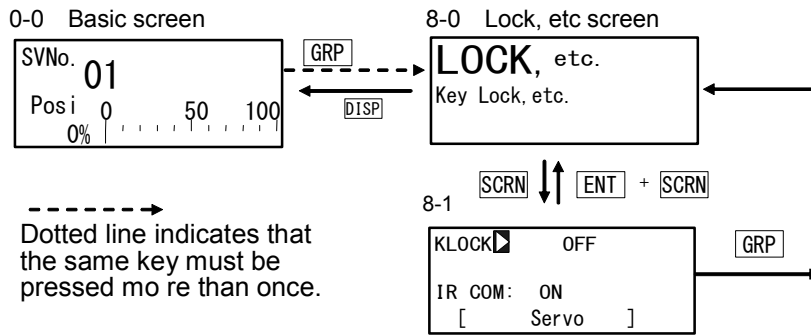

Servo: Servo output specification

6-2 Releasing the Key Lock

(1) Key lock screen display

To call up the LOCK, etc. screen group (group 8) from the basic screen, press the **GRP** key.

Press the **SCRN** key in the LOCK, etc. screen group to switch to the screens for making and changing setups.

The following is an example of screen transitions “with feed back” specification.

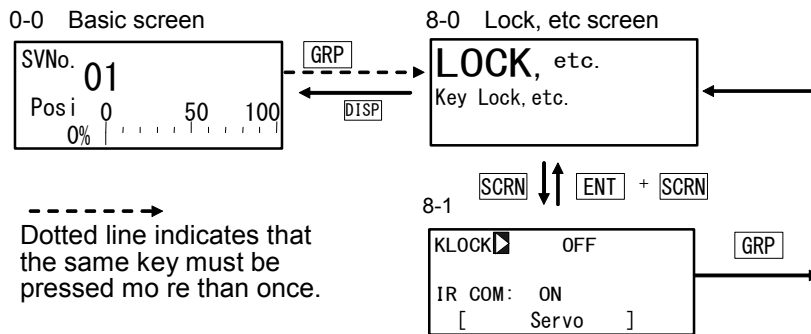

Select parameters in screens by pressing the **↻** key.

Set parameters by pressing the **◀**, **▼** or **▲** key, and press the **ENT** key to fix and register settings.

(2) Releasing the key lock

When the key lock is applied, the **🔒** (key mark) is displayed at the relevant parameter on the LCD screen indicating that the parameter cannot be set or its settings changed. The following shows the procedure for releasing the key lock.

8-1		Setting range	OFF, LOCK1, LOCK2, LOCK3
		Initial value	OFF

- OFF Releases the key lock
- LOCK1 Locks parameters other than SV related, AT, MAN, or EVENT/ DO action point
- LOCK2 Locks parameters other than SV related parameters
- LOCK3 Locks all parameters (excluding the key lock parameter itself)

For details on parameters that are locked, see "18 List of Parameters.

7 INPUT SETTINGS

7-1 Infrared Communication

Allow the infrared communication using S5004 (Infrared Communication Adapter, selling separately). IR COM should be ON before the instrument parameters are set via infrared communication.

Parameter Assistant Software is also used for this communication. For details, see "Parameter Assistant Instruction Manual" which can be accessed from its Help menu.

8-1

Setting range ON, OFF

Initial value ON

KLOCK : OFF
IR COM <input checked="" type="checkbox"/> ON
[Servo]

ON Infrared communication by S5004 is available.

OFF Infrared communication by S5004 is not available.

7-2 Measuring Range

Before performing setup or changes to the setup, set control action to the standby mode (STBY: ON).

For details on control standby operation, see "16-8 Control Standby (STBY)."

(1) Range setting

Set the code No. to RANGE referring the Measuring Range Code Table below.

7-2

RANGE	06 (K3)
Sc_L	0.0°C
Sc_H	800.0°C
UNIT:°C	DP XXX.X

Setting range 01 to 19, 31 to 58, 71 to 77, 81 to 87

Initial value 06 (K3)
K T/C 0.0 to 800°C

When the current input is 4 to 20 mA or 0 to 20 mA, select RANGE No.85 (1 to 5V) or 84 (0 to 5V), and attach a receiving resistor of 250Ω 0.1% across input terminals for use.

When the range is changed in the above screen, the following confirmation message will be displayed.

Press the key to select YES, and press the key to apply the setting.

WARNING Params Initialize proceed? NO	→	WARNING Params Initialize proceed? YES
---	---	--

Caution

- ◆ When the range is changed, the above warning message will be displayed, and parameters will be initialized.
For details on parameters that are initialized, see "18 List of Parameters"

(2) Range scaling

Set the measuring range (scaling) when the selection range is voltage input and current input (corresponding to code Nos.71 to 77, 81 to 87). Sc_L is scaling of the lower limit side of PV, and Sc_H is scaling of the higher limit side of PV. Before performing setup or changes to the setup, set control action to the standby mode (STBY: ON).

For details on control standby operation, see "16-8 Control Standby (STBY)."

The key mark is displayed and this item cannot be set in the case of RTD or thermocouple input.

Reverse scaling is not possible.

7-2

RANGE:	86 (0~10 V)
Sc_L	0.0 %
Sc_H:	100.0 %
UNIT: %	DP: XXXX.X

Settable range	-19999 to 30000 digit
Measuring range	Minimum span: 10 digit Maximum span: 30000 digit Any setting within the above ranges is possible. (Note that Sc_L < Sc_H)
Initial value	Sc_L: 0 digit, Sc_H: 1000 digit

The maximum span is $(Sc_H - Sc_L) \leq 30000$.

When an Sc_L is set that causes the span to exceed 30000, a value that does not exceed span is automatically set to Sc_H.

When scaling is changed in the above screen, the following confirmation message will be displayed.

Press the key to select YES, and press the key to apply the setting. The range will be changed.

WARNING Params Initialize proceed? NO	→	WARNING Params Initialize proceed? YES
---	---	--

Caution

- ◆ When the range is scaled, the above warning message will be displayed, and parameters will be initialized. For details on parameters that are initialized, see "18 List of Parameters."
-

■Measuring Range Code Table

Input Type	Sensor Type	Code	Symbol	Measuring range	Measuring range	
Universal Input	Thermo couple	B *1	01	B	0.0 to 1800.0 °C	0 to 3300 °F
		R	02	R	0.0 to 1700.0 °C	0 to 3100 °F
		S	03	S	0.0 to 1700.0 °C	0 to 3100 °F
		K	04	K1	-100.0 to 400.0 °C	-150.0 to 750.0 °F
		K	05	K2	0.0 to 400.0 °C	0.0 to 750.0 °F
		K	06	K3	0.0 to 800.0 °C	0.0 to 1500.0 °F
		K	07	K4	0.0 to 1370.0 °C	0.0 to 2500.0 °F
		K *2	08	K5	-200.0 to 200.0 °C	-300.0 to 400.0 °F
		E	09	E	0.0 to 700.0 °C	0.0 to 1300.0 °F
		J	10	J	0.0 to 600.0 °C	0.0 to 1100.0 °F
		T *2	11	T	-200.0 to 200.0 °C	-300.0 to 400.0 °F
		N	12	N	0.0 to 1300.0 °C	0.0 to 2300.0 °F
		PL II	13	PLII	0.0 to 1300.0 °C	0.0 to 2300.0 °F
		PR40 - 20 *3	14	PR40-20	0.0 to 1800.0 °C	0 to 3300 °F
		WRe5-26	15	WRe5-26	0.0 to 2300.0 °C	0 to 4200 °F
		U	16	U	-200.0 to 200.0 °C	-300.0 to 400.0 °F
		L	17	L	0.0 to 600.0 °C	0.0 to 1100.0 °F
		K *4	18	K	10.0 to 350.0 K	10.0 to 350.0 K
		AuFe-Cr *5	19	AuFe - Cr	0.0 to 350.0 K	0.0 to 350.0 K
	RTD	Pt100 (old) JIS/IEC		31	Pt 1	-200.0 to 600.0 °C
			32	Pt 2	-100.00 to 100.00 °C	-150.0 to 200.0 °F
			33	Pt 3	-100.0 to 300.0 °C	-150.0 to 600.0 °F
			34	Pt 4	-60.00 to 40.00 °C	-80.00 to 100.00 °F
			35	Pt 5	-50.00 to 50.00 °C	-60.00 to 120.00 °F
			36	Pt 6	-40.00 to 60.00 °C	-40.00 to 140.00 °F
			37	Pt 7	-20.00 to 80.00 °C	0.00 to 180.00 °F
			38	Pt 8 *6	0.000 to 30.000 °C	0.00 to 80.00 °F
			39	Pt 9	0.00 to 50.00 °C	0.00 to 120.00 °F
			40	Pt10	0.00 to 100.00 °C	0.00 to 200.00 °F
			41	Pt11	0.00 to 200.00 °C	0.0 to 400.0 °F
			42	Pt12 *7	0.00 to 300.00 °C	0.0 to 600.0 °F
			43	Pt13	0.0 to 300.0 °C	0.0 to 600.0 °F
			44	Pt14	0.0 to 500.0 °C	0.0 to 1000.0 °F

Input Type	Sensor Type	Code	Symbol	Measuring range	Measuring range
Universal Input	RTD JPt100 (old)JIS	45	JPt 1	-200.0 to 500.0 °C	-300.0 to 900.0 °F
		46	JPt 2	-100.00 to 100.00 °C	-150.0 to 200.0 °F
		47	JPt 3	-100.0 to 300.0 °C	-150.0 to 600.0 °F
		48	JPt 4	-60.00 to 40.00 °C	-80.00 to 100.00 °F
		49	JPt 5	-50.00 to 50.00 °C	-60.00 to 120.00 °F
		50	JPt 6	-40.00 to 60.00 °C	-40.00 to 140.00 °F
		51	JPt 7	-20.00 to 80.00 °C	0.00 to 180.00 °F
		52	JPt 8 *6	0.000 to 30.000 °C	0.00 to 80.00 °F
		53	JPt 9	0.00 to 50.00 °C	0.00 to 120.00 °F
		54	JPt10	0.00 to 100.00 °C	0.00 to 200.00 °F
		55	JPt11	0.00 to 200.00 °C	0.0 to 400.0 °F
		56	JPt12 *7	0.00 to 300.00 °C	0.0 to 600.0 °F
		57	JPt13	0.0 to 300.0 °C	0.0 to 600.0 °F
		58	JPt14	0.0 to 500.0 °C	0.0 to 900.0 °F
Voltage (mV)	-10 to 10 mV	71	-10 to 10 mV	Initial value: 0.0 to 100.0 Measuring range: Any value in the following ranges can be set by the scaling function. Scaling range: -19999 to 30000 digit Span: 10 to 30000 digit Scale over occurs when the input measured value exceeds 32000.	
	0 to 10 mV	72	0 to 10 mV		
	0 to 20 mV	73	0 to 20 mV		
	0 to 50 mV	74	0 to 50 mV		
	10 to 50 mV	75	10 to 50 mV		
	0 to 100 mV	76	0 to 100 mV		
	-100 to 100 mV	77	-100 to 100 mV		
Voltage (V)	-1 to 1 V	81	-1 to 1 V	When used with 0 to 20mA, 4 to 20mA current input, select either of measuring range codes 84 and 85, and attach a shunt resistor of 1/2W 250Ω±0.1% to the input terminals.	
	0 to 1 V	82	0 to 1 V		
	0 to 2 V	83	0 to 2 V		
	0 to 5 V	84	0 to 5 V		
	1 to 5 V	85	1 to 5 V		
	0 to 10 V	86	0 to 10 V		
-10 to 10 V	87	-10 to 10 V			
<p>*1: In the case of thermocouple B, accuracy is not guaranteed at temperatures 400°C and 750°F or below.</p> <p>*2: Accuracy at temperatures -100°C (-148°F) or below ±(0.5%FS+1 digit).</p> <p>*3: Accuracy is ±(0.3%FS+1°C).</p> <p>*4: Accuracy of thermocouple K is ±(0.75%FS+1K)/10.0 to 30.0K, ±(0.30%FS+1K)/30.0 to 70.0K, ±(0.25%FS+1K)/70.0 to 350.0K.</p> <p>*5: Accuracy of the AuFe-Cr thermocouple is ±(0.25%FS+1K).</p> <p>*6: Higher limit scale over occurs when the input measured value exceeds 32.000.</p> <p>*7: Higher limit scale over occurs when the input measured value exceeds 320.000.</p>					

7-3 Unit

Select the unit to be used in the preset measuring range.

Before performing setup or changes to the setup, set control action to the standby mode (STBY: ON).

For details on control standby operation, see "16-8 Control Standby (STBY)."

Only temperature (°C, °F) can be selected for RTD and TC input.

7-2

```
RANGE: 86(0~ 10V)
Sc_L:   0.0°C
Sc_H:   100.0°C
UNIT: °C DP: XXXX.X
```

RTD, TC

Setting range °C, °F

Initial value °C

Voltage, Current

Setting range °C, °F, %, None

Initial value %

When the unit is changed in the above screen, the following confirmation message will be displayed at TC and RTD input. At voltage or current input, this warning message will not be displayed.

Press the key to select YES, and press the key to apply the setting. The unit will be changed.

```
WARNING
Params Initialize
proceed? NO
```

```
WARNING
Params Initialize
proceed? YES
```

Caution

- ◆ When the unit is changed, the above warning message will be displayed, and parameters will be initialized.
For details on parameters that are initialized, see "18 List of Parameters."

7-4 Decimal Point Position

(1) Decimal point position

Set the decimal point position in the PV display screen when the selection range is voltage input and current input (corresponding to code Nos.71 to 77, 81 to 87).

Before performing setup or changes to the setup, set control action to the standby mode (STBY: ON).

For details on control standby operation, see "16-8 Control Standby (STBY)."

The key mark is displayed and this item cannot be set in the case of RTD or TC input.

7-2

```
RANGE : 86(0~ 10V)
Sc_L:   0.0%
Sc_H:   100.0%
UNIT : % DP: XXXX.X
```

Setting range xxxx.x to x.xxxx

Initial value xxxx.x

(2) Switching the lowest digit past the decimal point

The lowest digit past the decimal point of measuring ranges determined by the range setting can be set.

Note, however, that this function cannot be used for measurement ranges without digits past the decimal point.

This screen is not displayed in the case of voltage input and current input.

7-3

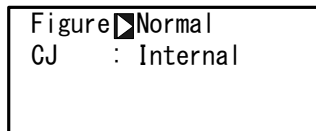

Setting range

Normal, Short

Initial value

Normal

Normal Displays the measuring range indicated in the Measuring Range Code Table.

Short Discards the lowermost digit past the decimal point of the measuring range indicated in the Measuring Range Code Table.

The EVENT/DO and PV Bias setting ranges do not change even if Figure is set to Short. When EVENT/DO and PV Bias is set with Figure set to Short and Normal is switched to, the values of EVENT/DO and PV Bias sometimes change.

When "Figure" is changed in the above screen, the following confirmation message will be displayed.

Press the key to select YES, and press the key to apply the setting.

"Figure" will be changed.



Caution

- ◆ When the lowest digit is changed, the above warning message will be displayed, and parameters will be initialized. For details on parameters that are initialized, see "18 List of Parameters."
-

7-5 Cold Junction Compensation

(1) Thermocouple cold junction compensation

Set whether to perform cold junction compensation during TC input (corresponding to code Nos. 01 to 19) internally or externally.

Normally, set to internal compensation. Set to external compensation when greater accuracy is required.

7-3

Figure: Normal
CJ <input checked="" type="checkbox"/> Internal

Setting range

Internal, External

Initial value

Internal

8 I/O AUXILIARY SETTINGS

8-1 PV Compensation Value

(1) PV bias

This item is used to compensate for error in the indicated temperature, for example, in the sensor/connected peripherals.

7-1

PV Bias	0.0
PV Filter	OFF
PV Slope	1.000

Setting range -10000 to 10000 digit

Initial value 0 digit

(2) PV filter

When the PV signal contains noise, the control result sometimes is adversely affected by fluctuation of PV signals.

The PV filter is used to decrease this influence and stabilize control.

7-1

PV Bias	0.0
PV Filter	OFF
PV Slope	1.000

Setting range OFF, 1 to 100s

Initial value OFF

PV filtering is performed by First Order Lag computation.

The filter time constant can be set up to 100 seconds.

When a large time constant is set, noise removal performance increases. However, in control systems having a fast response, noise removal is adversely affected.

(3) PV slope

This item sets the PV slope during voltage input and current input.

The screen is not displayed during RTD and TC input.

7-1

PV Bias	0.0
PV Filter	OFF
PV Slope	1.000

Setting range 0.500 to 1.500

Initial value 1.000

Execution $PV = A \times X + B$ where, A = PV slope, B=Bias, X = PV input

When this item is used in combination with square root extraction operation and linearizer approximation, this slope is applied to the result of square root extraction operation and linearizer approximation.

8-2 Square Root Extraction Operation

Signals having square root characteristics such as in the measurement of flow rates can be linearized.

This item is set during voltage input and current input.

This item is not displayed in the case of RTD or TC input.

(1) Enabling the square root extraction operation

The square root extraction operation function is valid when SQ.Root is set to ON.

7-3

SQ. Root <input checked="" type="checkbox"/> OFF
--

Setting range OFF, ON

Initial value OFF

(2) Low cut

This item functions only when the square root extraction operation function is enabled.

In square root operation, the PV fluctuates greatly by a slight fluctuation of the input value in the vicinity of signal zero.

"Low cut" is a function for outputting "0" (zero) to PV at the preset input value or lower.

Setting low cut prevents action from becoming unstable when there is noise on the input signal line.

7-3

SQ. Root <input checked="" type="checkbox"/> ON
Low Cut: 1.0%

Setting range 0.0 to 5.0%

Initial value 1.0%

The set value of low cut is 0.0 to 5.0% of the PV input range.

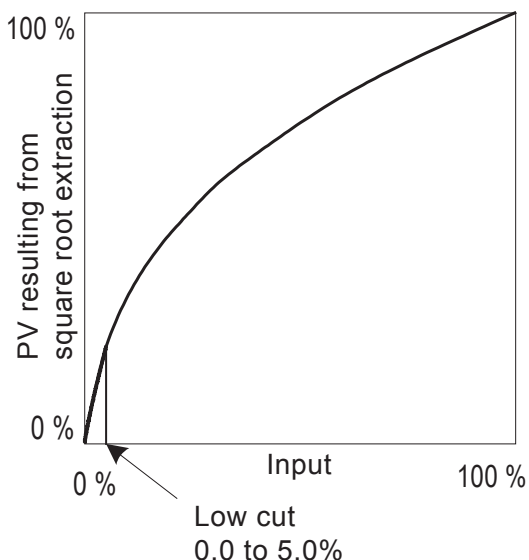

8-3 Ten-Segment Linearizer Approximation

(1) Enabling ten-segment linearizer approximation

This setting is only for voltage input and current input.

This function performs linearization based upon ten-segment approximation when the PV input is a non-linear signal.

7-4

PMD <input type="checkbox"/> OFF

Setting range OFF, ON
Initial value OFF

(2) Setting input points

Set the input points in the case of ten-segment linearizer approximation input.

Up to 11 points can be set. 11 points (B1 to B11) can be set for PV display (%) on PV 11 inputs (A1 to A11).

For each input point, B1 is set to A1, B2 for A2 and so forth until B11 is set to A11, and linear interpolation is executed between input points.

7-4~7-9

PMD: ON
A 1 <input type="checkbox"/> 0.00%
B 1: 0.00%

A10 <input type="checkbox"/> 90.00%
B10: 90.00%
A11: 100.00%
B11: 100.00%

Set the PV display value (B) to PV input value (A).

Setting range An, Bn: -5.00 to 105.00%
Initial value An, Bn: 0.00%
n=1 to 11

■ Ten-segment linearizer setting (example)

In the following figure, A1, B1 to A6, B6 are used to set input points with four intermediate points.

For before A1 and from A6 onwards, the ramps of (A1, B1) to (A2, B2) and the ramps of (A5, B5) to (A6, B6) are applied.

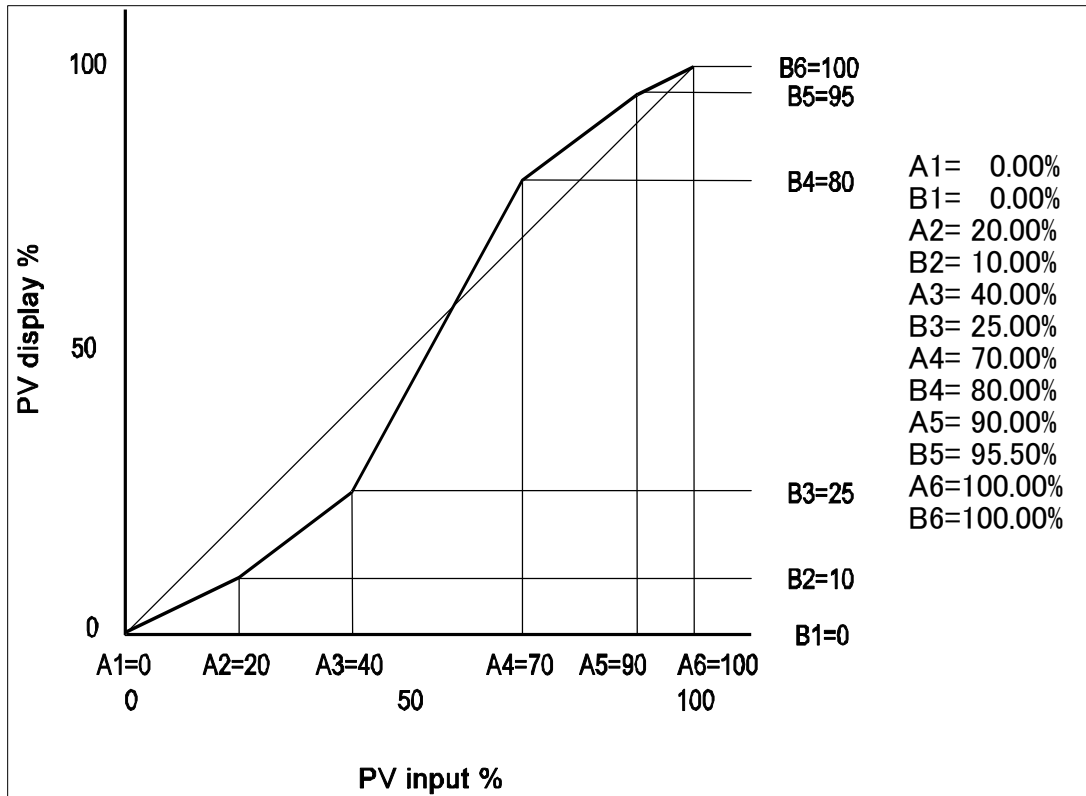

Caution

- ◆ Set so that the relationship $A_n < A_{(n+1)}$ is satisfied. When the relationship becomes $A_n \geq A_{(n+1)}$, $A_{(n+1)}$ onwards becomes invalid.

8-4 Compensating Analog Output

Error that occurs in analog output can be compensated.

1. Release the key lock if it is applied.
For details on how to release the key lock, see "6-2 Releasing the Key Lock."
2. Set controller control action to the standby mode (STBY: ON).
For details on control standby operation, see "16-8 Control Standby (STBY)."
3. Set the count value.
Call up the LOCK, etc. top screen (group 8) from the basic screen by the **GRP** key.

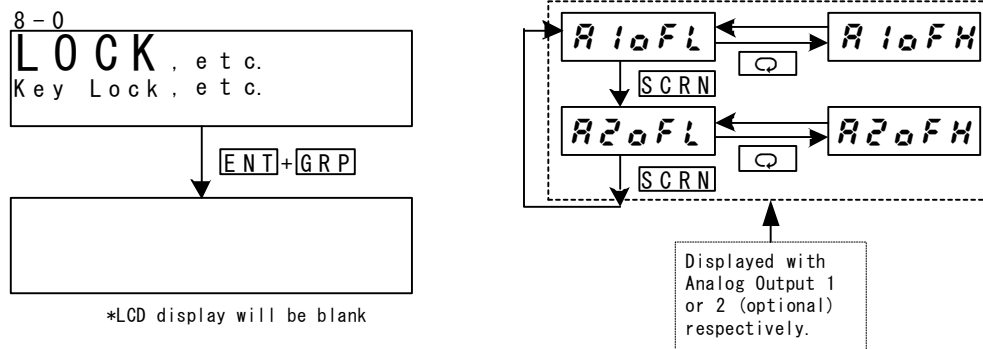

Move to the setup screen by holding the **ENT** key and pressing the **GRP** key for at least 3 seconds, and select the output to compensate by pressing the **SCRN** and **↻** keys. Set the count value currently displayed on the SV display with the **▼** or **▲** key, and press the **ENT** key to fix and register settings

PV Display	Description	PV Display	Description
<i>A1oFL</i>	Analog Output 1 lower limit value	<i>A1oFH</i>	Analog Output 1 higher limit value
<i>A2oFL</i>	Analog Output 2 lower limit value	<i>A2oFH</i>	Analog Output 2 higher limit value

When "0" is set, settings return to factory defaults.

4. When you have finished setting the above, press the **DISP** key to return to the LOCK, etc. screen.

This page left intentionally blank.

9 SV VALUE & REMOTE SV VALUE

9-1 Setting the SV Value

(1) SV limiter

The SV limiter is used to prevent input of wrong target set values. Set the lower limit value (SV L) and higher limit value (SV H) of the set value (SV) setting range.

2-12

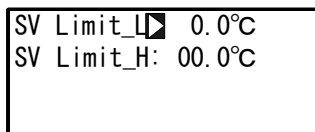

Setting range Within measuring range
SV Limit_L < SV Limit_H

Initial value

SV Limit_L: Lower limit value of measuring range

SV Limit_H: Higher limit value of measuring range

The SV limiter set here is valid on all execution SVs. The remote execution SV monitor is not influenced by the SV limiter, and indicates the value corresponding to the remote input value. The execution SV is restricted by the SV limit value.

Caution

- ◆ When the SV limiter is changed after the SV value is set, SV values that fall outside the limit are discarded, and sometimes the setting is disabled. To avoid this state, be sure to set the SV limiter before setting the SV value.

(2) Set value (SV)

For details on how to set and change the currently executing SV, see "16-3 Setting the Execution SV No." Operations in the SV setup screen are as follows:

1. Enter the set value by the ◀, ▼ or ▲ key.
2. Press the **ENT** key to fix and register the set value.

2-1



This screen is for setting the SV value of each SV No.

Setting range Within SV setting range

Initial value 0 or value of lower limit side of the measuring range, whichever is larger

9-2 Setting the Remote SV Value

(1) Monitoring the remote SV

The remote input signals are displayed in the REM set value monitor screen corresponding to the measuring range.

The remote SV value cannot be set by operating the front panel keys.

2-11

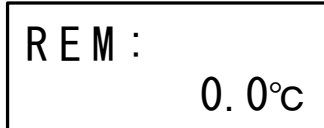

The remote SV monitor displays the values corresponding to the remote input values without being influenced by the SV limit.

(2) Remote tracking

This function copies the remote SV value to the local SV value of any SV No.

The control program can be run while the SV value is changed by the analog remote signal, and fixed-value operation can be switched to by the remote SV value at a certain moment in time.

2-13

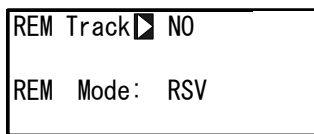

Selection item NO, YES

Initial value NO

■ Operation at REM Track: YES

When the execution SV is switched to by key operation from the remote SV, the remote SV value is written to the SV value of the newly switched to SV No.

When REM is assigned to DI, and the remote SV is switched to the execution SV by an external contact signal, the remote SV value is copied to the switch destination SV value.

When EXT is set by SV No. selection switching, and the execution SV selected by an external switch is switched to from the remote SV, the remote SV value is copied to the switch destination SV value.

Remote tracking does not function when the remote SV value results in a scale over error.

■ Operation at REM Track: NO

Remote tracking does not function.

(3) Remote mode

Various computations can be performed on remote signals, and the result taken as the remote SV.

In the RSV mode, the "Ratio:" row in the following screen is not displayed.

2-13

REM Track: NO
REM Mode <input checked="" type="checkbox"/> RT
Ratio: 1.000

Setting item	RSV, RT
Initial value	RST (Ratio is not displayed.)

RSV The remote input is used as the regular RSV (remote SV) input.

RT Computations are performed on the remote input signal values and used with ramp applied.

A bias can also be added to input signal values.

For details on RT, see "9-3 (1) Remote Ratio."

9-3 Setting the Remote SV Compensation Value

(1) Remote ratio

This item is valid only when RT is selected in the Remote Mode.

Set the value of A in the following formula for generating the remote SV (REM SV):

$$\text{REM SV} = A \times X + B$$

A: Remote ratio, B: Remote bias X: Remote input signal

2-13

REM Track: NO
REM Mode: RT
Ratio <input type="checkbox"/> 1.000

Setting range 0.001 to 30.000

Initial value 1.000

When ratio is set to remote (bias = 0)

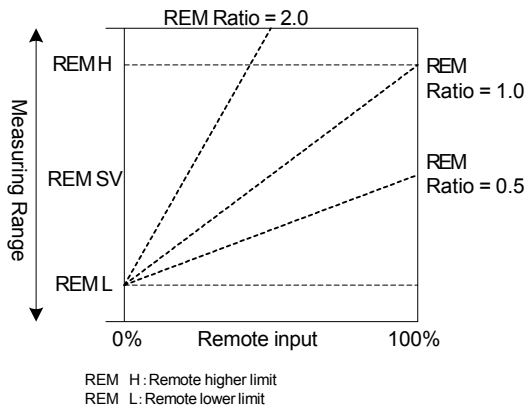

When ratio and bias are set to remote

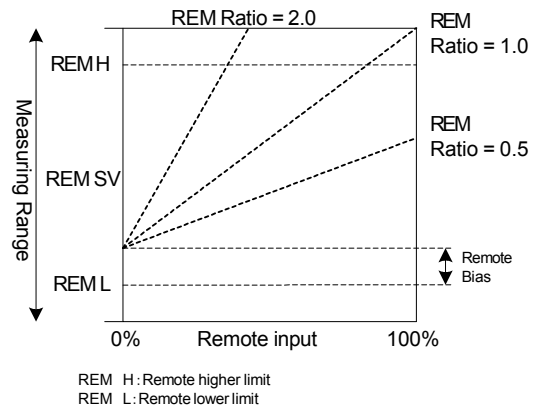

In the RT mode, generate the remote SV value by scaling the remote input signal, applying the remote ratio on the result of scaling, and applying a bias if required.

For details on remote bias, see "9-3 (2) Remote bias," and for details on remote scaling, see "9-3 (4) Remote scale."

Note

- ◆ When an extremely large remote ratio is set, the range that can be used as the remote signal input becomes extremely narrow, and when an extremely small remote ratio is set, the range of the remote SV becomes extremely narrow. Applying a large bias further narrows the usable range. Take the above points into consideration when using this function.
- ◆ The REM SV value obtained by generating and computing remote SV is subject to restrictions by the SV limit value.

(2) Remote bias

Set the value of B in the following formula for generating the remote SV (REM SV):

In RT mode REM SV = A x X + B
 In RSV mode REM SV = X + B

A: Remote ratio, B: Remote bias, X: Remote input signal

2-14

REM Bias	<input checked="" type="checkbox"/>	0.0 °C
Filt	<input type="checkbox"/>	OFF
Sc_L		0.0 °C
Sc_H		800.0 °C

The error of the remote input signal can be compensated.

Setting range -10000 to 10000 digit
 Initial value 0 digit

Though the remote bias can be set up to ±10000 Unit, the assured accuracy is the range 0 to 100% of the remote signal input value.

Take care to prevent the value that is actually used from exceeding this accuracy range.

(3) Remote filter

Noise on the remote input signal line sometimes causes unstable control.

For this reason, this device incorporates a remote filter function for reducing the influence of noise to stabilize control.

Filtering is performed by first order lag computation.

Here, set that time constant.

2-14

REM Bias	<input checked="" type="checkbox"/>	0.0 °C
Filt	<input checked="" type="checkbox"/>	OFF
Sc_L		0.0 °C
Sc_H		800.0 °C

Setting range OFF, 1 to 300
 Initial value OFF
 Unit : seconds

Setting a large time constant increases noise removal performance. This, however, sometimes adversely influences control systems that require a fast response speed.

(4) Remote scale

Set the range that is to be used as SV by the remote input signal.
Set scaling within the measuring range.

2-14

REM Bias:	0.0 °C
Filt:	OFF
Sc_L <input checked="" type="checkbox"/>	0.0 °C
Sc_H:	800.0 °C

Setting range

Within measuring range
(reverse scaling possible)
 $Sc_L \leq REM\ L, REM\ H \leq Sc_H$

Initial value

REM L:
REM H

Lower limit of measuring range
Higher limit of measuring range

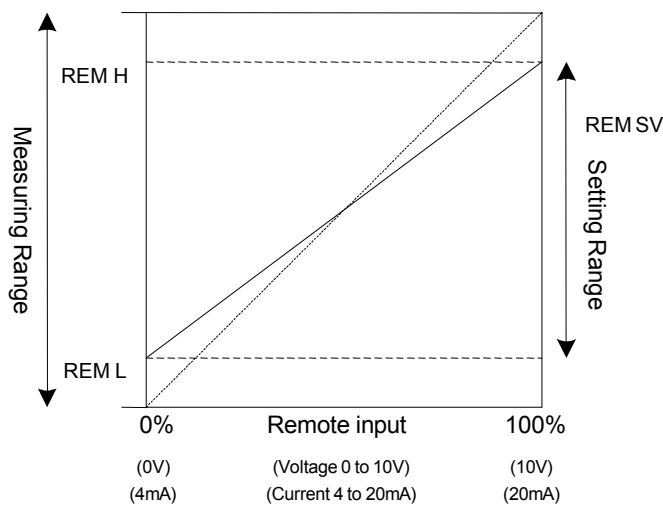

Set the value of remote input signal 0% to REM L.
Set the value of remote input signal 100% to REM H.

In the case of reverse scaling, set the value of remote input signal 0% to REM H, and the value remote input signal 100% to REM L.

9-4 Setting the Remote PID No. and Square Root Extraction Operation

Set square root extraction operation when remote signals undergo square root extraction operation to produce the execution SV, for example, in ratio control of flow rates.

(1) Setting the remote PID No.

The remote PID corresponding to the remote SV can be set.

Select the remote PID from PID No.1 to PID No.10.

Note, however, that the setting here becomes invalid when the zone PID function is in use.

2-15	Setting range	1 to 10
<div style="border: 1px solid black; padding: 5px;"> REM PID <input type="checkbox"/> 1 SQ. Root: OFF </div>	Initial value	1

(2) Enabling remote square root extraction operation function

The square root extraction operation is valid when SQ. Root is ON.

2-15	Setting range	OFF, ON
<div style="border: 1px solid black; padding: 5px;"> REM PID 1 SQ. Root <input type="checkbox"/> OFF </div>	Initial value	OFF

(3) Low cut

Low cut functions when square root extraction operation is valid.

In square root extraction operation, slight fluctuations of the input value near the signal zero cause the result to fluctuate considerably.

Low cut functions to set 0 (zero) to the REM signal when the input value is at the preset value or less.

This prevents action from becoming unstable when the REM input signal contains noise.

2-15	Setting range	0.0 to 5.0%
<div style="border: 1px solid black; padding: 5px;"> REM PID: 1 SQ. Root: ON Low Cut <input type="checkbox"/> 1.0% </div>	Initial value	1.0%
		If REM signal is 1.0% or below, the value is adjusted to 0.

9-5 Setting the Ramp

This function gradually changes the set value without subjecting the load to sudden change when the target set value (SV) is changed.

Here, set four items: ascending ramp value (RAMP Up), descending ramp value (RAMP Down), ramp unit (RAMP Unit), and ramp ratio (RAMP Ratio).

(1) Ramp value

Set the ascending ramp value (RAMP Up) and descending ramp value (RAMP Down).

Ascending ramp or descending ramp is automatically selected at ramp execution.

When the ascending/descending ramp values are changed during execution of ramp control, they are immediately reflected in control.

2-16

RAMP	Up	<input checked="" type="checkbox"/>	OFF
	Down	<input type="checkbox"/>	OFF
	Unit		/Sec
	Ratio		/1

Setting range RAMP Up : OFF, 1 to 10000

RAMP Down : OFF, 1 to 10000

Initial value RAMP Up : OFF

RAMP Down : OFF

(2) Ramp unit time

Set the unit times of ascending ramp value (RAMP Up) and descending ramp value (RAMP Down).

Set either seconds (Sec) or minutes (Min) as the unit time of the rate-of-change.

When the ramp unit time is changed during execution of ramp control, it is immediately reflected in control.

2-16

RAMP	Up	<input type="checkbox"/>	OFF
	Down	<input type="checkbox"/>	OFF
	Unit	<input checked="" type="checkbox"/>	/Sec
	Ratio		/1

Setting range /Sec, /Min

Initial value /Sec

(3) Ramp ratio

Set this to use an even gentler slope in ramp control.
 The amount of change per unit time can be set to 1/10 of the regular time.
 When the ramp ratio is changed during execution of ramp control, it is immediately reflected in control.

2-16		Setting range /1, /10 Initial value /1
RAMP	Up: OFF	
	Down: OFF	
	Unit: /Sec	
	Ratio: /1	

RAMP Ratio : /1 Ramp control is performed at the preset ramp unit time.
 RAMP Ratio : /10 Ramp control is performed at 1/10 of the amount of change per unit.

(4) Executing ramp control

Ramp control is executed by switching the execution SV No.
 For details on switching this SV No., see "16-2 Switching the Execution SV No."
 During execution of ramp control, the RMP status lamp blinks.
 To abort ramp control and immediately execute steady-state control for switching to the target SV value, press the **ENT** and **DISP** keys simultaneously in the basic screen (group 0).
 For details on operation of pausing/resuming ramp control, see "16-9 Pausing/Resuming Ramp Control (RAMP)."
 While ramp control is paused, the RMP status lamp lights.
 The following is an example of screen transition "without feedback".

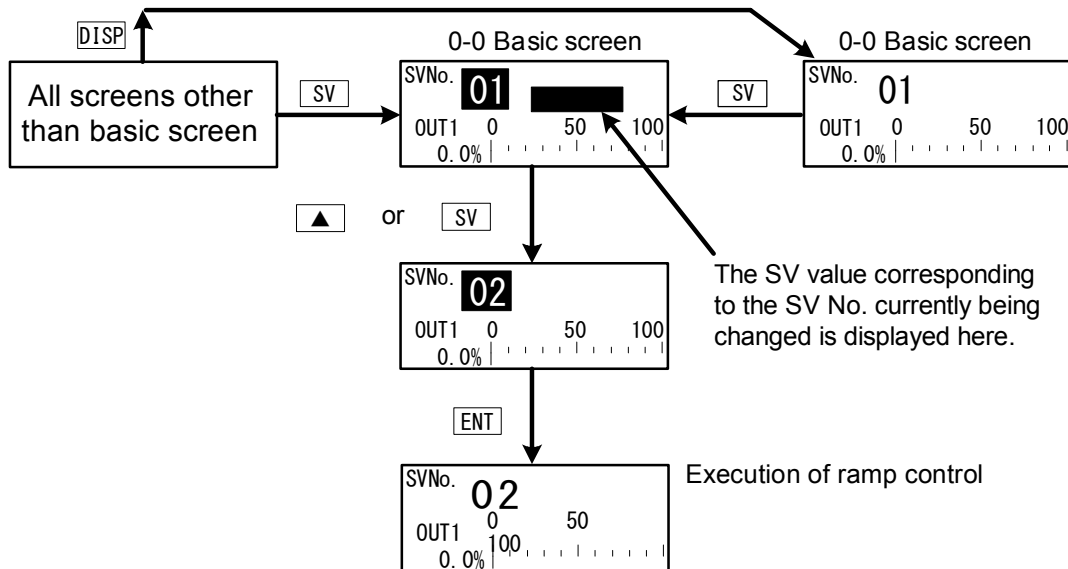

For execution of ramp control, the following conditions must be satisfied.

These conditions are common to both front panel keys and external switch input.

- ◆ Execution of auto tuning must not be in progress (AT: ON).
- ◆ The mode must not be standby (STBY: ON).
- ◆ RAMP Up or RAMP Down must not be OFF.

Note

- ◆ Ramp control is not performed when the SV No. is switched to the remote SV.
The same applies when the remote SV is switched to the local SV.
 - ◆ When the power is turned OFF during ramp control, and then turned back ON again, ramp control is stopped, and the execution SV is switched to the SV No. that was used as the target SV No.
-

10 PID SETTING

10-1 Proportional Band (P)

"Proportional band" refers to the range in which the size of the control output changes in proportion to the difference (deviation) between the measured value (PV) and the set value (SV).

Here, set the percentage (%) that control output is made to change with respect to the measuring range.

When a wide proportional band is set, the change in the control output with respect to deviation decreases, and the offset (constant deviation) increases.

When a narrow proportional band is set, the change in the control output increases, and the offset decreases. If too narrow a proportional band is set, hunting (vibration) occurs, and action becomes similar to that of ON-OFF control.

When P=OFF is set, control becomes ON-OFF control, and auto tuning cannot be executed.

3-1

PID01-OUT1			
P	3.0%	MR:	0.0%
I	120s	SF:	0.40
D	30s		

Setting range OFF, 0.1 to 999.9%

Initial value 3.0%

10-2 Integral Time (I)

Integral action is a function for correcting the offset (constant deviation) that occurs due to proportional action.

When a long integral time is set, offset correction action is weak, and it takes a long time to correct the offset. The shorter an integral time is set, the stronger the correction action becomes. However, if too short an integral time is set, hunting (vibration) occurs, and action becomes similar to that of ON-OFF control.

3-1

PID01-OUT1			
P	3.0%	MR:	0.0%
I	120s	SF:	0.40
D	30s		

Setting range OFF, 1 to 6000 s

Initial value 120 s

When auto tuning is executed with I=OFF, the manual reset (MR) value is computed and automatically set.

For details on automatic setting of MR, see "10-4 Manual Reset (MR)."

10-3 Derivative time (D)

Derivative action functions in two ways. It forecasts changes in the control output to reduce influence caused by external disturbance, and suppresses overshoot caused by integral action to improve control stability.

The shorter a derivative time is set, the weaker derivative action becomes. Alternatively, the longer a derivative time is set, the stronger derivative action becomes. However, if too long a derivative time is set, hunting (vibration) occurs, and action becomes similar to that of ON-OFF control.

3-1

PID01-OUT1	
P: 3.0%	MR: 0.0%
I: 120s	SF: 0.40
<input checked="" type="checkbox"/> D: 30s	

Setting range OFF, 1 to 3600 s
Initial value 30 s

When auto tuning is executed with D=OFF, computation is performed only by PI value (proportional and/or integral).

10-4 Manual Reset (MR)

This function sets I (integral time) to OFF, and manually corrects offset that occurs when control action is performed by P or P+D.

When a + side MR value is set, the control result shifts to the + side, and when a - MR value is set, the control action shifts to the - side. The amount of shift is proportional to the size of the numerical value that is set.

3-1

PID01-OUT1	
P: 3.0%	<input checked="" type="checkbox"/> MR: 0.0%
I: OFF	SF: 0.40
D: 30s	

Setting range -50.0 to 50.0 %
Initial value 0.0 %

■ Automatic setting of MR

When auto tuning is executed, the manual reset (MR) value is computed and automatically set.

During PID control, the MR is used as the target load ratio in PID initial computation.

For this reason, to reduce overshoot when the power is turned ON or STBY = ON is set to OFF, set a small MR value to lower this target load ratio.

When auto tuning is performed by PID control on this device, the load ratio is calculated so that offset is decreased even if there is no I action, and the value corresponding to the manual reset is automatically set.

This function enables control results superior to those enabled by regular PID control to be obtained.

10-5 Action Hysteresis (DF)

This item sets the hysteresis (DF) in ON-OFF control action when P is set to OFF. When a narrow hysteresis is set, chattering is more likely to occur on the output. When a wide hysteresis is set, chattering, etc. can be avoided and stable control action can be obtained, however, ON-OFF cycling increases.

3-1

PID01-OUT1	
P:	OFF
DF	2.0

Setting range 1 to 9999 digit
 Initial value 20 digit

10-6 Set Value Function (SF)

This function determines the strength for preventing overshooting that occurs during Expert PID control.

Set Value Function is valid only when integral action (PI or PID) is set.

3-1

PID01-OUT1	
P:	3.0% MR: 0.0%
I:	OFF SF 0.40
D:	30s

Setting range 0.00 to 1.00
 Initial value 0.40

SF = 0.00 Regular PID control is carried out, and the overshoot correction function is disabled.

SF → Small Overshoot correction is small.

SF → Large Overshoot correction is large.

■Reference: About PID action according to set value function (SF)

PID and PD action can be switched by the SF value during RAMP or REM.

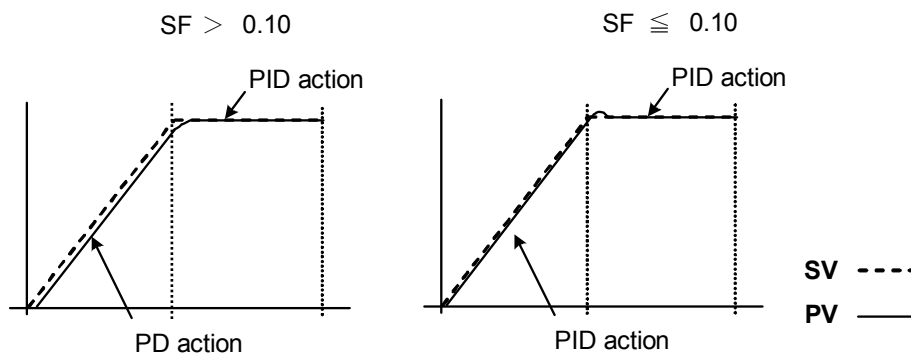

10-7 Output Limit Value (OUT1L to OUT1H)

This is the screen for setting the lower limit value and higher limit value of the control output value corresponding to the PID No.

Though regular control is performed using the initial values as they are, these lower limit and higher limit values are used for control that requires higher accuracy.

In a heating control specification, set a lower limit value when the return value is slow arriving due to overshoot at the upper side. For control targets whose temperature immediately drops when the temperature rise is slow and output is lowered, set a large higher limit value.

3-2

PID01	OUT1L ▣	0.0%
	OUT1H:	100.0%

Setting range Lower limit value : 0.0 to 99.9 %
 Higher limit value : 0.1 to 100.0 %
 (Lower limit value < Higher limit value)

Initial value Lower limit value : 0.0 %
 Higher limit value : 100.0 %

Note

- ◆ The output limiter is invalid during contact output or SSR drive voltage output when P=OFF is set and ON-OFF control is selected.

10-8 Zone PID

This function sets two or more zones in a measuring range and switches different PID values in each zone for use.

When this function is used, the optimum PID value can be set to each temperature range (zone) so that satisfactory controllability is obtained in a wide temperature range as two or more SVs can be used for performing ramp control.

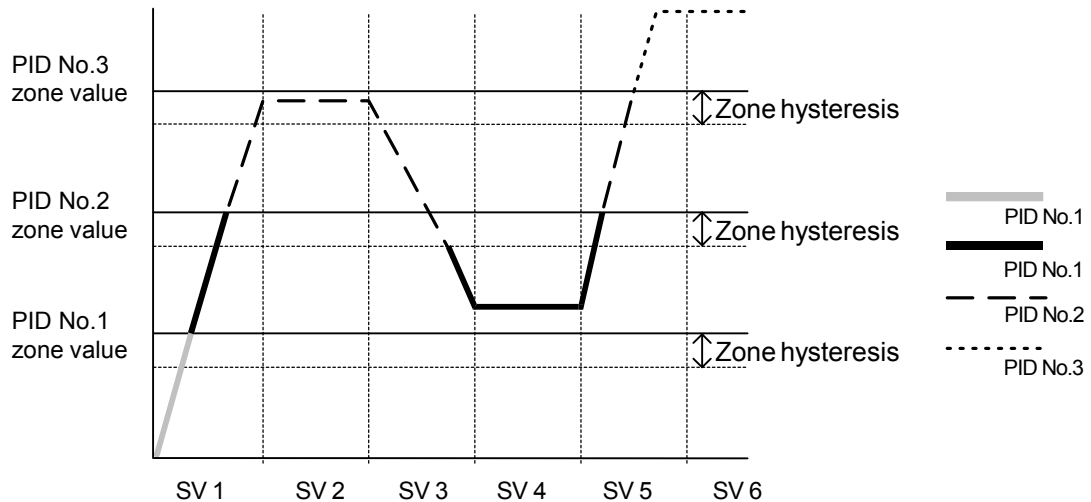

Note

- ◆ When the same zone value is set to multiple PID Nos., the PID No. having the smallest No. is executed.
- ◆ Even if the zone value or zone hysteresis is changed with the SV value inside zone hysteresis, the execution PID No. will not be changed until the SV No. leaves zone hysteresis.

(1) Selecting Zone PID

Select whether or not to use zone PID.

When this function is used, select whether to set the zone by SV or by PV.

3-21

Zone PID1	<input checked="" type="checkbox"/>	OFF
HYS1:		2.0

Setting range OFF, SV, PV

Initial value OFF

OFF Zone PID function is disabled.

PID No. is switched interlocked with the SV No.

SV Zone PID function of SV is used.

PV Zone PID function of PV is used.

(2) Zone hysteresis

The hysteresis can be set with respect to the zone set value.
This hysteresis is valid for all zone set values.

3-21

Zone PID1:	OFF
HYS1	2.0

Setting range 0 to 10000 digit
Initial value 20 digit

(3) PID zone

Set the zone (temperature range) to be used by the zone PID function for each PID No.

3-1

PID01-OUT1			
P:	3.0%	MR:	0.0%
I:	120s	SF:	0.40
D:	30s	ZN	0.0°C

Setting range Within measuring range
Initial value 0 digit

Note

- ◆ When the same zone value is set to two or more PID Nos., the PID having the smallest No. is executed.
- ◆ To use the Zone PID function, Zone hysteresis and Zone PID must be set.

10-9 Auto Tuning Point

To avoid hunting caused by limit cycle using the SV value in execution of PID auto tuning, set the AT action at the point where the PV leaves the SV value.

3-22

Tuning: Auto Tuning
Hunting: 0.2%
AT Point <input checked="" type="checkbox"/> 0.0°C

Setting range 0 to 10000 digit

Initial value 0 digit

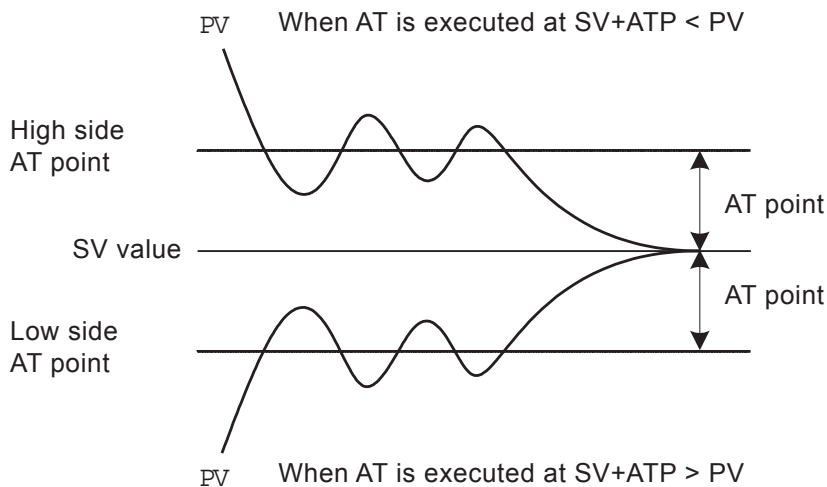

Note

- ◆ For the AT Point setting, the AT action points above and below the SV value as a deviation are automatically set.
- ◆ If auto tuning is executed when PV is outside the preset upper and lower AT action points, auto tuning is performed at the AT action point between the PV and SV.
- ◆ If auto tuning is executed when the PV value is inside the upper and lower AT action points, auto tuning is performed by the SV value.
- ◆ When AT Point is set to 0 (zero), the SV value becomes the AT action point.

This page left intentionally blank.

11 EVENT & DO SETTING

11-1 Monitor Screens

(1) DO monitor

4-1

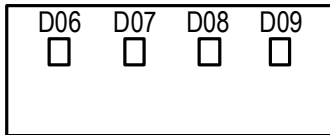

When a signal is output to DO, □ is lit reversed to ■. DO6 to DO9 are optional, and are not displayed when they are not available.

(2) Logic monitor

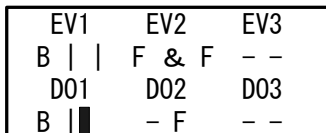

This screen is displayed when “LOGIC” is assigned to one or more EVENT/DOS.

LOGIC I: OR &: AND ^: XOR
 Input B: Buffer F: Flip flop I: Inverter
 Becomes white reversed on black in an active state.

In the screen above, Buffer and Inverter are assigned to DO1 to make the device perform OR operation on both inputs.

11-2 EVENT/DO Action

Note that if you have changed this setting, action set points (SP) and hysteresis (DF) parameters are initialized.
 Some of the types of events that can be assigned vary according to the EV No. and DO No. DO6 to DO9 are optional.
 Logic operations assignable to EV1 to EV3 and DO1 to DO3 are AND, OR and XOR.
 Logic operations assignable to DO4 and DO5 are Timers and Counters.
 Direct assignable to D06 to D09 with communication option.
 Posi.H, Posi.L, or POT.ER can be assigned when feedback potentiometer is used.

4-2

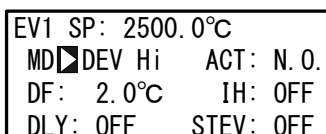

Setting range See List of Event (EVENT/DO) Assignments.
 Initial value EV1 : DEV Hi
 EV2 : DEV Low
 Others : NONE

■List of Event (EVENT/DO) Assignments

No.	Mode	Action	EV1 to EV3	DO1 to DO3	DO4 to DO5	DO6 to DO9
(1)	None	No action	○	○	○	○
(2)	DEV Hi	Higher limit deviation value	○	○	○	○
(3)	DEV Low	Lower limit deviation value	○	○	○	○
(4)	DEV Out	Outside higher/lower limit deviation	○	○	○	○
(5)	DEV In	Inside higher/lower limit deviation	○	○	○	○
(6)	PV Hi	PV higher limit absolute value	○	○	○	○
(7)	PV Low	PV lower limit absolute value	○	○	○	○
(8)	SV Hi	SV higher limit absolute value	○	○	○	○
(9)	SV Low	SV lower limit absolute value	○	○	○	○
(10)	AT	Auto tuning execution in progress	○	○	○	○
(11)	MAN	Manual operation in progress	○	○	○	○
(12)	REM	Remote operation in progress	○	○	○	○
(13)	RMP	Ramp control execution in progress	○	○	○	○
(14)	STBY	Control action not in progress	○	○	○	○
(15)	SO	PV, REM scale over	○	○	○	○
(16)	PV SO	PV scale over	○	○	○	○
(17)	REM SO	REM input scale over	○	○	○	○
(18)	LOGIC	Logic operation (AND, OR, XOR)	○	○	---	---
		Logic operation (Timer/Counter)	---	---	○	---
(19)	Direct	Direct output (with communication option)	---	---	---	○
(20)	Posi.H	Position higher limit absolute value	○	○	○	○
(21)	Posi.L	Position lower limit absolute value	○	○	○	○
(22)	POT.ER	Feedback potentiometer (R2) error	○	○	○	○

■ DLY can be set.

MD Indication	EVENT (DO) Type	Setting Range	Initial Value
DEV Hi	Higher limit deviation value	-25000 to 25000 digit	25000 digit
DEV Low	Lower limit deviation value	-25000 to 25000 digit	-25000 digit
DEV Out	Outside higher/lower limit deviation	0 to 25000 digit	25000 digit
DEV In	Inside higher/lower limit deviation	0 to 25000 digit	25000 digit
PV Hi	PV higher limit absolute value	Within measuring range	Measuring range higher limit value
PV Low	PV lower limit absolute value	Within measuring range	Measuring range lower limit value
SV Hi	SV higher limit absolute value	Within SV setting range	Higher limit value of SV
SV Low	SV lower limit absolute value	Within SV setting range	Lower limit value of SV
Posi.H	Position higher limit absolute value	0 to 100%	100%
Posi.L	Position lower limit absolute value	0 to 100%	0%

In the case of DEV Out and DEV In, two plus and minus action points are set when a deviation value is input.

■ **EVENT/DO Action Diagrams**

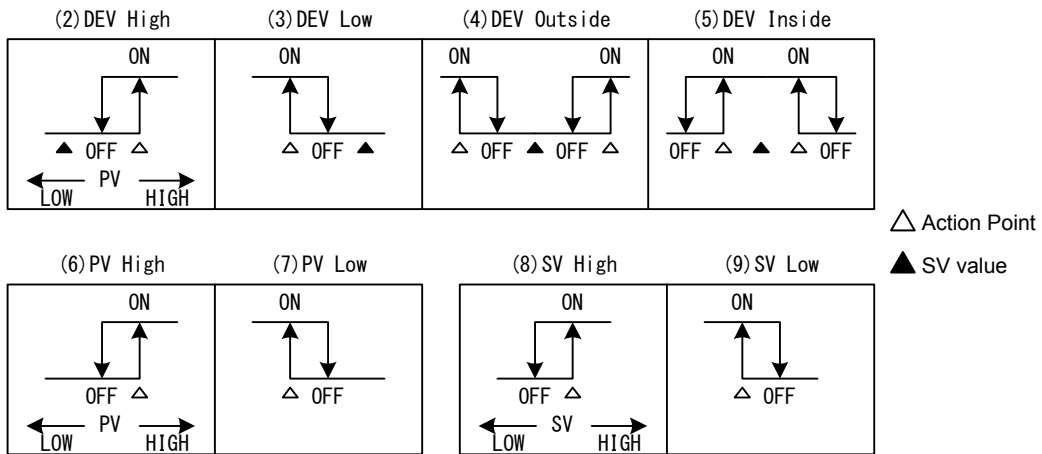

- ♦ ON/OFF in the diagrams indicate operation mode.
 EVENT/DO output conforms to the setting of output characteristics.(Open/Close)

Note

- ♦ If Posi.H, Posi.L, or POT.ER is assigned to EVENT/DO under the specification of "with feedback", then switched to "without feedback", the EVENT mode is changed to "None".

(1) **Output characteristics**

Select the output characteristics.

4-2

EV1 SP: 2500.0°C
MD: DEV Hi ACT <input checked="" type="checkbox"/> N.O.
DF: 2.0°C IH: OFF
DLY: OFF STEV: OFF

Setting range N.O., N.C.
 Initial value N.O

- N.O.(normally open) When EVENT/DO turns ON, contacts are closed or output transistor turns ON.
- N.C.(normally closed) When EVENT/DO turns ON, contacts are opened or output transistor turns OFF.

(2) Hysteresis

This item is displayed when event modes (2) to (9), (20) or (21) are selected in EVENT/DO action.

Set the hysteresis between ON action and OFF action.

Setting a wide hysteresis can avoid chattering, etc. and obtain stable action.

4-2

EV1 SP: 2500.0°C	
MD: DEV Hi	ACT N. O.
DF <input checked="" type="checkbox"/> 2.0°C	IH: OFF
DLY: OFF	STEV: OFF

For the case of (2) to (9)

Setting range 1 to 9999 digit

Initial value 20 digit

For the case of (20) or (21)

Setting range 0.1 to 5.0%

Initial value 0.1%

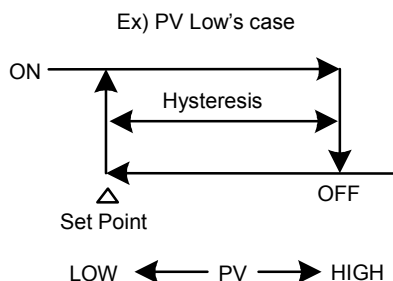

(3) Delay time

This item is displayed when event modes (2) to (9), (20) or (21) are selected in the EVENT/DO action.

This function delays the time until EVENT is output after generation of an event source.

4-2

EV1 SP: 2500.0°C	
MD: DEV Hi	ACT N. O.
DF: 2.0°C	IH: OFF
DLY <input checked="" type="checkbox"/> OFF	STEV: OFF

Setting range OFF, 1 to 9999 s

Initial value OFF

Note

- ◆ EVENT/DO is not output when the source of the signal output disappears during the delay time. When the source is generated again, the event delay time up till then is cleared, counting of the item is performed from the beginning.
- ◆ When the delay time is set to OFF, EVENT/DO is output at the same time that the source of EVENT/DO is generated.
- ◆ The delay time can be changed when an EVENT/DO output source is generated and it is within the delay time action. Note, however, that the delay time is measured not from the moment that it is changed but from the moment that the output source is generated.
- ◆ The delay time for EVENT/DO action becomes invalid when a scale over occurs.

(4) Inhibit action

This item is displayed when modes (2) to (9), (20) or (21) are selected in the EVENT/DO action.

Inhibit action does not output EVENT/DO even if the PV value is in the EVENT/DO action region, and outputs EVENT/DO when the PV value leaves the EVENT/DO action region and enters the EVENT/DO action region again at power ON or at STBY cancellation.

Select either of the following taking inhibit action and event action at a scale over into consideration.

4-2

EV1 SP: 2500.0°C
MD: DEV Hi ACT N.O.
DF: 2.0°C IH <input type="checkbox"/> OFF
DLY: OFF STEV: OFF

Setting range OFF, 1, 2, 3

Initial value OFF

OFF Inhibit action is not performed.

1 Inhibit action is executed at power ON or when the control state changes from standby to execution (STBY ON→OFF).

2 Inhibit action is executed at power ON, when the control state changes from standby to execution (STBY ON→OFF) or when the state of SV is changed.

3 Inhibit action is not performed. (Action OFF at scale over input error.)

Note

- ◆ When IH is set to 1 or 2, EVENT/DO action turns ON when a scale over error occurs on the EVENT/DO set side.
- ◆ When IH is set to 3, EVENT/DO action turns OFF when a scale over error occurs on the EVENT/DO set side.
- ◆ To output an alarm when a scale over error occurs with IH set to 3, assign scale over (SO) to other EVENT/DOs.

(5) Event action at inhibit

Select whether or not to perform event output during inhibit when event modes (2) to (9), (20) or (21) are selected.

4-2

EV1 SP: 2500.0°C
MD: DEV Hi ACT N.O.
DF: 2.0°C IH: OFF
DLY: OFF STEV <input checked="" type="checkbox"/> OFF

Setting range OFF, ON

Initial value OFF

OFF Event output becomes invalid during inhibit.

ON Event output becomes valid during inhibit.

11-3 Event Logic Operations

This function performs logic operations on inputs from two DIs and outputs the result to EVENT/DO.

This function sets a logic gate to each of the two inputs, performs logic operation (AND, OR or XOR) on these inputs, and outputs the result to EVENT/DO.

Events that can be selected are EV1 to EV3 and DO1 to DO3.

■ Event logic operation block diagram

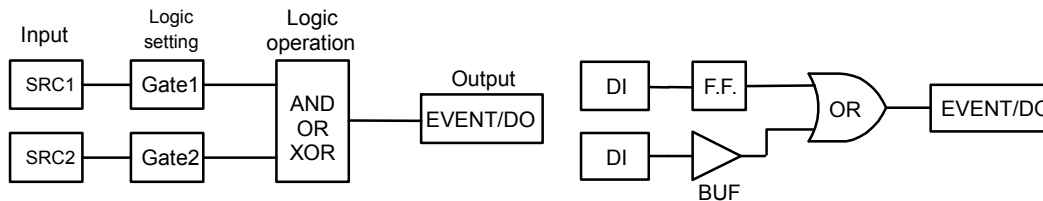

(1) Logic operation mode (Log MD)

The following screen is displayed when logic operation (LOGIC) is selected as the operation mode.

4-5

D01	Log MD	AND
	MD:	LOGIC ACT: N.O.
	SRC1:	None Gate1: BUF
	SRC2:	None Gate2: BUF

Setting range AND, OR, XOR
Initial value AND

AND	Logical product	EVENT/DO turn on when both of the two inputs turn on (logic 1).
OR	Logical sum	EVENT/DO turn on when either the two inputs turns on (logic 1).
XOR	Exclusive OR	EVENT/DO turn on when one of the two inputs turns on (logic 1) and the other turns off (logic 0).

(2) Assigning logic operation input (SRC1, SRC2)

Assign the DI No. to two inputs (SRC1 & SRC2) for logic operation.
DI that can be assigned are DI1 to DI10 (DI5 to DI10 are optional).

4-5

D01	Log MD:	AND
	MD:	LOGIC ACT: N.O.
	SRC1	None Gate1: BUF
	SRC2:	None Gate2: BUF

Setting range DI1 to DI10
Initial value None (no assignment)

Note

- ◆ When another function is assigned to DI and that DI signal is input, logic operation is executed and the function assigned to DI acts simultaneously.
- ◆ When logic operation input is set to None, the input logic becomes logic 0 regardless of the BUF, INV and FF settings.

(3) Logic operation input logic (Gate1, Gate2)

Set the logic of the two inputs for logic operation.

4-5

DO1	Log MD: AND
MD: LOGIC	ACT: N. O.
SRC1: None	Gate1: <input checked="" type="checkbox"/> BUF
SRC2: None	Gate2: BUF

Setting range BUF, INV, FF
Initial value BUF

BUF Buffer

DI input signals are handled as they are as input logic signals.

INV Inverter

DI input signals are reversed and the result is handled as the input logic signal.

FF Flip-flop

DI input signals are reversed and the result is handled as the input logic signal each time that the assigned DI turns ON.

When DI turns ON, that ON state is sustained even if it turns OFF later.

In this case, the input logic turns OFF when DI is ON next time.

Note

- ◆ The DI monitor indicator lights when an input signal is input. When Gate is set to INV, logic becomes Logic 1 when DI input is OFF, and Logic 0 when DI input is ON. For this reason, the logic state becomes the reverse of the DI monitor.
- ◆ When Gate is set to FF, the logic state is alternately switched between Logic 1 and Logic 0 each time that DI is input. For this reason, the logic state can be confirmed on the logic operation monitor.
- ◆ When DI assignment is set to None, no action is performed even if the DI signal is input.

11-4 Timers/Counters

With this timer/counter function, DI is taken as input and DO is taken as output.

When input is generated, and after it passes preset time/preset counts, DO is output.

The timers and counters operate regardless of the control action of this device, and output a one-shot pulse of one second.

Only DO4 and DO5 can be assigned for the timers and counters.

The following screen is displayed only when the operation mode is set to logic operation (LOGIC).

(1) Timer time

The time can be set within the range 1 to 5000 seconds only when the mode (Log MD) is set to timer.

4-9

DO5 Time	<input checked="" type="checkbox"/> OFF
MD: LOGIC	ACT: N. O.
SRC: DI3	
Log MD: Timer	

Setting range OFF, 1 to 5000 s
Initial value OFF

(2) Counter

The count can be set within the range 1 to 5000 only when the mode (Log MD) is set to counter.

The pulse width of DI must be 100 ms or more.

4-8

D04 Count	<input checked="" type="checkbox"/>	OFF
MD:	LOGIC	ACT: N. O.
SRC:	None	
Log MD:	Counter	

Setting range OFF, 1 to 5000

Initial value OFF

(3) Assigning input (SRC)

The DIs that can be assigned are DI1 to DI10 (DI5 to DI10 are optional).

4-9

D05 Time :	OFF
MD:	LOGIC ACT: N. O.
SRC	<input checked="" type="checkbox"/> None
Log MD:	Timer

Setting range None, DI1 to DI10

Initial value None (no assignment)

Note

- ◆ When another function is assigned to DI and that DI signal is input, logic operation is executed and the function assigned to DI acts simultaneously.
- ◆ When DI assignment is set to None, no action is performed even if the DI signal is input.

(4) Mode (Log MD)

Select and set timer or counter.

4-9

D05 Time :	OFF
MD:	LOGIC ACT: N. O.
SRC:	D13
Log MD	<input checked="" type="checkbox"/> Timer

Setting range Timer, Counter

Initial value Timer

Timer DO turns ON after DI is input and a preset time elapses.

Counter DO turns ON when DI input count reaches the preset value.

12 OPTION SETTING (DI, AO, COM)

12-1 DI

DI is digital input for external control based upon an externally input non-voltage contact signal or an open collector signal.

Actions can be selected, and assigned to DI1 to DI10 (DI5 to DI10 are optional).

(1) DI monitor screen

is displayed reversed to when a signal is input to DI regardless of whether or not DI is assigned.

DI5 to DI10 are optional and are not displayed when they are not available

5-1

DI1	DI2	DI3	DI4	DI5
<input type="checkbox"/>	<input type="checkbox"/>	<input type="checkbox"/>	<input type="checkbox"/>	<input type="checkbox"/>
DI6	DI7	DI8	DI9	DI10
<input type="checkbox"/>	<input type="checkbox"/>	<input type="checkbox"/>	<input type="checkbox"/>	<input type="checkbox"/>

(2) Selecting DI action

This is the assignment to DI.

LG is displayed for the DI to be used by input (SRC) in event logic operations. For details, See “11-3 (2) Assigning logic operation input (SRC1, SRC2)”.

5-2

DI1	<input checked="" type="checkbox"/> None	
DI2	: None	
DI3	: None	LG
DI4	: None	

■ List of DI Types

Mode	Action		No-action Conditions	Signal Detection
None	No action (factory default)		---	---
MAN	Switching of control output between auto/manual (when ON: manual)		AT, STBY	Level
REM	Switching of REM SV/LOCAL SV setting (when ON: REM SV setting)		AT	Level
AT	Switching of AT execution/stop (at ON "edge": AT execution)		MAN, STBY, RMP, REM	Edge
STBY	Switching of control execution/standby (when ON: standby)		None	Level
ACT	Switching of direct/reverse action on Output 1 characteristics (when ON: direct action)		AT, RMP	Level
Pause	Switching of pause/resume of ramp control (when ON: ramp pause)		---	Level
LOGIC	Logic operation (when ON: execution of logic operation and output to EV or DO)		None	Level
Preset1	Assignable to DI2	The external switching using Servo preset value is available by assigning Preset 1 to 3 to DI2 only.	MAN, STBY	Level
Preset2	Assignable to DI2 to DI3		MAN, STBY	Level
Preset3	Assignable to DI2 to DI4		MAN, STBY	Level
EXT_SV	External switching of SV No. Only DI7 can be set. (assigned to DI7 to DI10)		None	Level

Note

- ◆ The corresponding DI action details cannot be executed while parameters listed in the "No-action Conditions" column in the table of "List of DI Types" are being executed.
- ◆ Signal detection timing:

Level input	Action is maintained with DI input ON.
Edge input	Action is executed by DI input ON, and is maintained even if DI input turns OFF. Action is canceled by DI input ON again.
- ◆ Once a function is assigned to a DI, the same function cannot be set by the front panel keys as DI is given priority.
- ◆ When the same action is assigned to two or more DIs, the DI having the smallest No. is valid, and DIs having a larger No. are invalid.
For example, assignment to DI2 becomes invalid when MAN is assigned to DI1 and DI2.
- ◆ When a DI assignment is canceled during DI execution, the currently executing action is continued (excluding LOGIC operation).
For details on logic operation, see "11-3 Event Logic Operations".

12-2 Analog Output

This function is optional and is not displayed when it is not installed.
Two optional analog outputs (Ao1, Ao2) can be installed on this device.

(1) Analog output type

Select the type of analog output to assign

5-5

Ao1MD	PV
Ao1_L	0.0°C
Ao1_H	800.0°C

Setting range PV, SV, DEV, OUT1, Posi

Initial value Ao1 : PV

Ao2 : SV

PV : Measured value

SV : Target set value

DEV : Deviation of PV and SV

OUT1 : Control Output 1

Posi : Position value

(2) Scaling analog output

Set the lower limit/higher limit scale of analog output.
Reverse scaling is also possible.

5-5

Ao1MD	PV
Ao1_L	0.0°C
Ao1_H	800.0°C

The following table shows setting ranges and initial values.

(Ao1_L < Ao1_H, or Ao2_L < Ao2_H)

Analog Output Type	Setting Range	Initial Value	
		Ao1_L, Ao2_L	Ao1_H, Ao2_H
PV, SV	Within measuring range	Measuring range lower limit value	Measuring range higher limit value
DEV	-100.0 to 100.0%	-100.0 %	100.0%
OUT1	0.0 to 100.0%	0.0 %	100.0%
Posi	0 to 100%	0 %	100%

Note

- ◆ If "Posi" is assigned to an analog output type, then switched to "without feedback", the analog output type is changed to "PV".

12-3 Communication

(1) Setting communication

For details, refer to the separate manual "SR23 Series Digital Controller Communications (Interface) (RS-232C/RS-485) Instruction Manual (Detailed version)." This section explains only the setting items.

5-7

COM PROT	SHIMADEN
ADDR:	1
BPS :	9600
MEM :	EEP

PROT: Communication protocol
 Setting range SHIMADEN, MOD_ASC, MOD_RTU
 Initial value SHIMADEN

ADDR: Communication address
 Setting range 1 to 98
 Initial value 1

BPS: Communication speed
 Setting range 2400, 4800, 9600, 19200
 Initial value 9600

MEM: Communication memory mode
 Setting range EEP, RAM, R_E
 Initial value EEP

5-8

COM DATA	7
PARI :	EVEN
STOP :	1
DELY :	10 ms

DATA: Data length
 Setting range 7, 8
 Initial value 7

PARI: Parity
 Setting range EVEN, ODD, NONE
 Initial value EVEN

STOP: Stop bit
 Setting range 1, 2
 Initial value 1

DELY: Delay time
 Setting range 1 to 50ms
 Initial value 10ms

5-9

COM CTRL	STX_ETX_CR
BCC:	ADD

CTRL: Control code
 Setting range STX_ETX_CR, STX_ETX_CRLF, @:_CR
 Initial value STX_ETX_CR

BCC: Block check character
 Setting range ADD, ADD_two's cmp, XOR, None
 Initial value ADD

(2) Communication mode (COM)

Select whether or not to set or change various data using the front panel keys (local) or by communication (option).

1-2



Setting range	LOCAL, COM
Initial value	LOCAL

In the Local mode, the key sign is displayed at the communication selection, indicating that changing from LOCAL (local) to COM (communication) by the front panel keys isn't possible.

Even in the LOCAL mode, the Communication mode can be changed from LOCAL to COM by sending commands to the SR23 from the host.

In the COM mode, the Communication mode can also be changed from COM to LOCAL by operating the front panel keys.

The COM (communication) and LOCAL (local) selections can be set by communications.

LOCAL Settings can be made using the front panel keys.
(Settings cannot be made by communication.)

COM Settings can be made by communication.
(Settings cannot be made by the front panel keys.)

For details on communication, refer to the separate manual "SR23 Series Digital Controller, Communications(Interface) (RS-232C/RS-485) Instruction Manual (Detailed version)."

13 SERVO SETUP

13-1 Overview of Setup Procedure

Caution

- ◆ This product is a position-proportional controller for a control motor with limit switches. Please ensure that you always use this for the control motor with limit switches.

The procedure from the checking of setting status up to output adjustment of servo functions is shown as follows:

Please refer to the description of the relevant operation screen for the details.

■ In case of "With Feedback"

Procedure	Refer to
1. Check wiring	-
2. Select FB = ON from the setting screen for FB parameter. This setting can be made only when STBY = ON is selected.	13-4 (1)
3. Check wiring for the feedback potentiometer.	-
4. Setting of action characteristics (ACT)	13-2 (1)
5. Setting of output at STBY	13-2 (2)
6. Setting of output at ERR	13-2 (3)
7. Setting of output at POT. ERR (feedback potentiometer error)	13-2 (4)
8. Servo ZERO/SPAN adjustment	13-5
9. Confirmation/adjustment of DB (Dead Band)	13-4 (2)

■ In case of "Without Feedback"

Procedure	Refer to
1. Check wiring	-
2. Select FB = OFF from the setting screen for FB parameter. This setting can be made only when STBY = ON is selected.	13-4 (1)
3. Setting motor timing (TIME)	13-4 (3)
4. Setting servo action on start-up (BOOT) Please be aware that the controller assumes the position of the motor to be 50% when BOOT is set to "Stop"	13-4 (4)
5. Setting of Action Characteristics (ACT)	13-2 (1)
6. Setting of output at STBY	13-2 (2)

7.	Setting of output at ERR	13-2 (3)
8.	Servo ZERO/SPAN adjustment	13-5
9.	Confirmation/adjustment of DB (Dead Band)	13-4 (2)

13-2 Control Output (Servo Output)

(1) Action characteristics

Select either reverse action (heating specifications) or direct action (cooling specifications) as the output characteristics.

6-1

OUT1 ACT:	<input checked="" type="checkbox"/> Reverse
STBY:	Preset1
ERR:	Preset1
POT. ERR:	Stop

Setting range Reverse, Direct
Initial value Reverse

Reverse By this action, the smaller the measured value (PV) than the set value (SV), the higher the output.

This action is generally used for heating control.

Direct By this action, the larger the measured value (PV) than the set value (SV), the higher the output.

This action is generally used for cooling control.

Note

- ◆ Output characteristics cannot be switched during execution of auto tuning (AT).

(2) Output at standby

Set the output (position) at standby (STBY = ON, controller operation paused).

6-1 With Feedback

OUT1 ACT:	Reverse
STBY:	<input checked="" type="checkbox"/> Preset1
ERR:	Preset1
POT. ERR:	Stop

Setting range Stop, Preset1 to Preset7
Initial value Preset1

6-1 Without Feedback

OUT1 ACT:	Reverse
STBY:	<input checked="" type="checkbox"/> Close
ERR:	Close

Setting range Stop, Close, Open
Initial value Close

The action differs according to whether the setting is at "With Feedback" or "Without Feedback".

With Feedback Stop, or relevant servo preset value (P1 to P7) is applied.

Without Feedback Any one of these actions (Stop, Close or Open) is conducted.

For more information, please refer to "13-3 (2) Setting Servo preset value".

Note

- ♦ Output at standby is maintained without being affected even if an input error occurs.

(3) Output at input error

Setting the output (position) to be applied when and if control operation is stopped due to scale over (SO) which might occur during input measurement.

6-1 With Feedback

OUT1 ACT:	Reverse
STBY:	Preset1
ERR:	<input checked="" type="checkbox"/> Preset1
POT. ERR:	Stop

Setting range	Stop, Preset1 to Preset7
Initial value	Stop

6-1 Without Feedback

OUT1 ACT:	Reverse
STBY:	Close
ERR:	<input checked="" type="checkbox"/> Close

Setting range	Stop, Close, Open
Initial value	Close

The action differs according to whether the setting is at "With Feedback" or "Without Feedback".

With Feedback	Stop, or relevant servo preset value (P1 to P7) is applied.
Without Feedback	Any one of these actions (Stop, Close or Open) is conducted.

For more information, please refer to "13-3 (2) Setting Servo preset value".

Note

- ♦ Output at standby is given priority when an input error has occurred at standby (STBY = ON, controller operation paused).

(4) Output at feedback potentiometer error

Setting for "With Feedback"

Set the output for feedback potentiometer error.

6-1

OUT1 ACT:	Reverse
STBY:	Preset1
ERR:	Preset1
POT. ERR:	<input checked="" type="checkbox"/> Stop

Setting range	Stop, Close, Open
Initial value	Stop

Note

- ♦ Output at feedback potentiometer error is registered prior to that at standby or at input error.

(5) Rate-of-change limiter

This setting item limits the rate-of-change (%) per second. Setting this item to OFF disables the rate-of-change limiter.

This setting is used to avoid sudden changes in output.

6-2

Rate Limiter OUT <input checked="" type="checkbox"/> OFF

Setting range OFF, 0.1 to 100.0%/s

Initial value OFF

Note

- ◆ Repetitive occurrence of control output value which deviates beyond the threshold values of dead band (DB) may cause hunting to the control motor. To prevent this, set a larger value for dead band (DB) or set the output rate-of-change limiter.

13-3 Externally Switching Servo Preset Value

(1) Mechanism and action of external switching

This function is for switching the output to preset position values through external signals. Switching through external contact point is available when using two or more preset (position) values. Only DI2 to DI4 can be set.

In case one external switching point is assumed to be set, assign "Preset1" to DI2 in order to operate the controller using the position value that has been set to preset value 1 (P1) by input signal to DI2.

Similarly, when external switching are for 2 or 3 points, set "Preset2" to DI2, or when external switching is points are for 4 to 7, assign "Preset3" to DI2.

In case all signals for DI2 to DI4 are OFF, the controller outputs not by the preset values, but by PID control.

Moreover, when external switching of servo preset values is set, no other function may be assigned since the preset values are automatically assigned to DI2 and DI3 if "Preset2" is set to DI2, or assigned to DI2 to DI4 if "Preset3" is set to DI2.

5-2

DI1	: None
DI2	<input checked="" type="checkbox"/> None
DI3	: None
DI4	: None

Preset1: 1 preset value switching by DI2

Preset2: 3 preset values (max.) switching by DI2 and DI3

Preset3: 7 preset values (max.) switching by DI2 to DI4

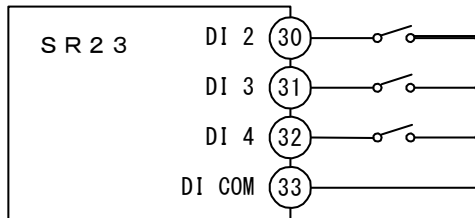

Setting Servo Preset	Preset3						
	Preset2						
	Preset1						
DI No.	P1	P	P3	P4	P5	P	P7
DI 2	●		●		●		●
DI 3		●	●			●	●
DI 4				●	●	●	●

● Indicates that the switch is ON.

Note

- ◆ When switching is done by a decimal switch, an unexpected value might be generated momentarily. To prevent this, be sure to set the decimal switch within the period of 100ms.

(2) Setting Servo preset value

■ In case of "With Feedback (FB = ON)"

You may switch the position output to any preset value through DI2 to DI4.

7 preset values can be assigned to P1 to P7 respectively. Switching is enabled by assigning "Preset1/2/3" to DI2 to DI4.

6-6

SERVO Preset	P4:	0%
P1 <input checked="" type="checkbox"/>	0%	P5: 0%
P2:	0%	P6: 0%
P3:	0%	P7: 0%

Setting range 0 to 100%
Initial value 0%

When one preset value is to be used, set it to P1 and assign the "Preset1" to DI2.
When up to 3 preset values are to be used, set them to P1 to P3 and assign the "Preset2" to DI2.

When up to 7 preset values are to be used, set them to P1 to P7 and assign the "Preset3" to DI2.

For more information on how to switch preset values, refer to the preceding section "13-3 (1) Mechanism and action of external switching".

■ In case of "Without Feedback (FB = OFF)"

The method of assignment for DI2 to DI4 is the same as that for "With Feedback". However, the action is automatically set to P1 = Stop, P2 = Close, P3 = Open, and P4 to P7 = Stop.

13-4 Setting Servo Operations

(1) Setting Servo feedback

Set whether feedback potentiometer is to be used or not (With or Without Servo feedback).

Set to ON for conducting feedback control with position signal from potentiometer. The feedback function is disabled when set to OFF.

6-3

SERVO FB <input checked="" type="checkbox"/>	ON
DB:	2. 0%

Setting range ON, OFF
Initial value ON

(2) Setting Servo Dead Band

Set the dead band for action between "Open" and "Close" outputs. Making the dead band smaller allows for more precise control.

However, if the dead band becomes too small, hunting may occur in output because the control motor may go too far due to its own inertia.

For the dead band (DB) and hysteresis, please refer to the "13-6 (6) Interrelation between Dead Band (DB) and hysteresis".

6-3

SERVO FB:	ON
DB	2.0%

Setting range 0.2 to 10.0%

Initial value 2.0%

(3) Setting motor timing

This setting is necessary for "Without Feedback (FB = OFF)".

Set the timing of the control motor required for full-stroke rotation. In case of "Without Feedback", the controller calculates the motor position from Open/Close signal timing.

6-4

SERVO FB:	OFF
DB:	2.0%
TIME	60s
BOOT:	Close

Setting range 5 to 300s

Initial value 60s

Note

- ◆ The motor's controllability may be adversely affected if wrong timing is set. Please check the motor's specifications.

(4) Setting Servo action on start-up

This setting is necessary for "Without Feedback (FB = OFF)".

In case of "Without Feedback", the motor position may become undetectable. To avoid such inconvenience, this function is provided for entering the control operation after setting the motor position to either fully closed or fully opened.

6-4

SERVO FB:	OFF
DB:	2.0%
TIME:	60s
BOOT	<input checked="" type="checkbox"/> Close

Setting range Stop, Close, Open
Initial value Close

- Stop Enter the control operation with the motor position as it is.
Enter the control operation by assuming the position of the motor to be 50% since the actual position is undetectable.
- Close Enter the control operation after setting to the fully closed position by outputting the Close signal for motor timing.
- Open Note that the motor moves to the fully closed position on start-up.
Enter the control operation after setting to the fully opened position by outputting the Open signal for motor timing.
Note that the motor moves to the fully opened position on start-up.

13-5 Servo Adjustment

Make sure to carry out ZERO/SPAN adjustment when activating. After having carried out the adjustment initially, readjust as necessary.

(1) Points for ZERO/SPAN adjustment and operation

This ZERO/SPAN adjustment can be carried out only at standby.

This can be conducted only through the ZERO/SPAN adjustment screen.

Do not move to any other screen during ZERO/SPAN adjustment; otherwise the ZERO/SPAN adjustment process will automatically stop.

Note that the adjustment process is stopped in Open status if the adjustment is ended at the Open position when the output at standby is set to STOP.

Caution

- Ensure that the wiring of motors (M1, M2, M3) and feedback potentiometer (R1, R2, R3) is correct before conducting ZERO/SPAN adjustment, otherwise the open position and close position may be inversely adjusted or the proper action may not be achieved.
- Proper action may not be achieved if the SPAN position and the ZERO position are inversely adjusted.
- Adjusting the distance between ZERO and SPAN too narrowly may cause hunting that may harm the service life of the motor or cause failure.
- In the above cases, check the wiring and readjust the ZERO/SPAN.

■ In case of "With Feedback (FB = ON)"

① Conducting ZERO/SPAN adjustment automatically

The adjustment process is automatically conducted in the order of the ZERO position to the SPAN position.

Caution

- "ERROR" is indicated when the ZERO/SPAN distance is less than approximately 10% of the feedback potentiometer.
If so, perform the automatic adjustment process once again, or perform an adjustment manually.
-

② Conducting ZERO/SPAN adjustment manually

Starting an adjustment either at the ZERO or the SPAN position may make no difference. Count values are always indicated at the right-position end at both the ZERO and SPAN lines on the LCD screen.

Caution

- Make sure to make adjustments so that the SPAN position count value is larger than the ZERO position count value.
 - Both of the count values shown on the right-side end will be highlighted when the ZERO/SPAN distance is less than approximately 10% of the feedback potentiometer.
 - In the cases above, no proper action may be guaranteed. Check and perform the adjustment process once again.
-

■ In case of "Without Feedback (FB = OFF)"

① Conducting ZERO/SPAN adjustment automatically

An adjustment operation may differ according to the setting of the servo action (BOOT) for starting.

In case of "BOOT = Stop or Close" Conduct adjustment with the control motor at fully closed position.

In case of "BOOT = Open" Conduct adjustment with the control motor at fully opened position.

② Conducting ZERO/SPAN adjustment manually

Conduct adjustment either at the ZERO or the SPAN position.
Hold down the Close key or the Open key until the motor stops.

(2) ZERO/SPAN automatic adjustment

There are automatic and manual adjustments for ZERO/SPAN adjustment.

In this section, you will find a description for ZERO/SPAN automatic adjustment.

For ZERO/SPAN manual adjustment, refer to the next section "13-5 (3) ZERO/SPAN manual adjustment".

For points to be attended to when conducting ZERO/SPAN adjustment, refer to the section "13-5 (1) Points for ZERO/SPAN adjustment and operation".

■ In case of "With Feedback"

The following is the procedure to be taken for automatically adjusting the fully closed position of the control motor to ZERO and the fully open position to SPAN.

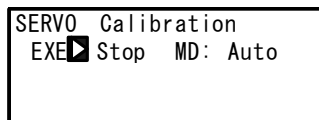

① Mode switching

Set the MD (mode) to "Auto" (Automatic).

② Starting automatic adjustment

Start ZERO/SPAN automatic adjustment by setting EXE to "Start" and pressing the **[ENT]** key.

③ Fix of ZERO position



"ZERO" blinks on the LCD screen at first, then Open output is turned ON for approx. 6 seconds, then the Close output will be turned ON. The ZERO position will be fixed at the point where the final control motor stopped and no fluctuation of feedback signal is detected.

④ Fix of SPAN position

Then, "SPAN" blinks on the LCD screen and Open output is turned ON. The SPAN position will be fixed at the point where the control motor stopped and no fluctuation of feedback signal is detected.

The automatic adjustment will be completed and the blinking of the "SPAN" indication will stop when the ZERO/SPAN positions are fixed.

Caution

- "ERROR" is indicated and no data is acquired when any abnormality has occurred in the feedback potentiometer, or when ZERO/SPAN distance is less than approximately 10% of the feedback potentiometer during ZERO/SPAN adjustment.
- Stop the ZERO/SPAN adjustment once if "ERROR" is indicated. (Press the  key to change EXE = Start to Stop and press the  key to confirm.)
- In the case mentioned above or if continuing the adjustment procedure with incorrect wiring of the motor and/or feedback potentiometer, Open-Close position may act inversely or hunting may occur, and no proper action may be guaranteed. If so, check and perform the adjustment procedure once again.

■ In case of "Without Feedback"

The following is the procedure to be taken for automatically adjusting the fully closed position of the control motor to the Close position or the fully opened position to the Open position.

6-5

```
SERVO Calibration
EXE: Stop MD  Auto
```

```
SERVO Calibration
EXE  Stop MD: Auto
```

```
SERVO Calibration
EXE  Start MD: Auto
ZERO
```

```
SERVO Calibration
EXE  Start MD: Auto
SPAN
```

① Mode switching

Set the MD (mode) to "Auto" (Automatic).

② Starting manual adjustment

Start ZERO/SPAN automatic adjustment by setting EXE to "Start" and pressing the  key.

③ Fix the ZERO position at the closed position (in the case of "BOOT = Stop or Close")

The "ZERO" blinks on the LCD screen and Close output is turned ON.

④ Fix the SPAN position at the open position (in case of "BOOT = Open")

The "SPAN" blinks on the LCD screen and Open output is turned ON.

Open output continues to be ON for the motor timing and consider the stop point as the open position.

The automatic adjustment will be completed and the blinking on the LCD display will stop when the closed or open position is fixed.

(3) ZERO/SPAN manual adjustment

In this section, ZERO/SPAN manual adjustment procedure is described.

For ZERO/SPAN automatic adjustment, refer to the preceding section "13-5 (2) ZERO/SPAN automatic adjustment".

ZERO/SPAN positions may be manually adjusted.

This procedure may be used when you do not want to make a fully closed or fully opened control operation, or when the ZERO position or SPAN position is set at an arbitrary position.

■ In case of "With Feedback"

The following is the procedure to be taken for manually adjusting the fully closed position of the motor to Close and the fully opened position to Open. Set ZERO as the Close position and SPAN as the Open position.

6-5

```
SERVO Calibration
EXE: Stop MD Manual
ZERO 宇 --- 4.5
SPAN 宇 --- 65.5
```

```
SERVO Calibration
EXE Start MD: Manual
ZERO: --- 4.0
SPAN: --- 65.0
```

```
SERVO Calibration
EXE: Start MD: Manual
ZERO CLOSE 3.5
SPAN: --- 65.0
```

```
SERVO Calibration
EXE: Start MD: Manual
ZERO: --- 3.5
SPAN OPEN 62.5
```

① Mode switching

Set the MD (mode) to "Manual".

② Starting manual adjustment

Start ZERO/SPAN manual adjustment by setting EXE to "Start" and pressing the **ENT** key.

③ Fix of ZERO position

Move the cursor to ZERO and turn the Close output to ON by pressing the **▼** (CLOSE) key.

Move the motor to the ZERO position by pressing the **▼** (CLOSE) key. and press the **ENT** key so that the numerical indication will stop blinking.

④ Fix of SPAN position

Move the cursor to SPAN and turn the Open output to ON by pressing the **▲** (OPEN) key.

Move the motor to the SPAN position by pressing the **▲** (OPEN) key and press the **ENT** key so that numerical indication will stop blinking.

ZERO or SPAN position may be set manually with the above mentioned procedure.

Caution

- Make sure to make adjustments so that the SPAN position count value is larger than the ZERO position count value.
- Both of the count values shown in the right-side end on the LCD will be highlighted when the ZERO/SPAN distance is less than approximately 10% of the feedback potentiometer.
- In the case mentioned above, Open-Close position may act inversely or hunting may occur in this circumstance. No proper action may be guaranteed. If so, check and perform the adjustment procedure again.

■ In case of "Without Feedback"

The following is the procedure to be taken for manually adjusting the fully closed position of the motor to the CLOSE position or the fully opened position to the Open position. Conduct the following procedure after setting the CLOSE position as ZERO and the Open position as SPAN.

Conduct the adjustment at either of the ZERO or SPAN position for manual adjustment in a "Without Feedback" configuration.

6-5

```
SERVO Calibration
EXE: Stop MD: Manual
ZERO: ---
SPAN: ---
```

① Mode switching

Set the MD (mode) to "Manual".

② Starting manual adjustment

Start ZERO/SPAN manual adjustment by setting EXE to "Start" and pressing the **[ENT]** key.

```
SERVO Calibration
EXE: Start MD: Manual
ZERO: ---
SPAN: ---
```

③ Fix of ZERO position

Move the cursor to ZERO and turn the CLOSE output to ON by pressing the **[▼]** (CLOSE) key.

Move the motor to the ZERO (CLOSE) position by pressing the **[▼]** (CLOSE) key.

```
SERVO Calibration
EXE: Start MD: Manual
ZERO: CLOSE
SPAN: ---
```

④ Fix of SPAN position

Move the cursor to SPAN and turn the Open output to ON by pressing the **[▲]** (OPEN) key.

Move the motor to the SPAN position by pressing the **[▲]** (OPEN) key.

```
SERVO Calibration
EXE: Start MD: Manual
ZERO: ---
SPAN: OPEN
```

Set the ZERO or SPAN position manually with the above-mentioned procedure.

(4) Adjustment of Dead Band (DB)

The following have the same content as that described in the section "13-4 (2) Setting Servo Dead Band".

To prevent hunting events caused by excessive sensitivity, conduct procedures for adjusting of dead band.

Set the dead band for Open and CLOSE outputs.

Making the dead band smaller allows for more precise control.

However, if the dead band becomes too small, hunting may occur in output because the control motor may go too far due to its own inertia.

6-3

SERVO FB: ON
DB <input type="checkbox"/> 2.0%

Setting range 0.2 to 0.0%

Initial value 2.0%

13-6 Servo Functions

(1) Priority of actions at Servo output

Priority at Servo Output is as follows:

- ① MAN output (Action for which the first priority is given)
- ② Output at feedback potentiometer error (in case of "With Feedback")
- ③ Output at standby
- ④ Output with preset value
- ⑤ Output at error
- ⑥ PID control output

(2) MAN actions at servo output

Switching to MAN mode at Servo output is possible both at STBY ON and OFF (The action for which the first priority is given).

Under the MAN mode at Servo output, the motor is not controlled by setting the OUT value, but directly controlled by Open/Close key operation.

(3) Interrelation between assignment of preset output and control action

The action differs according to the setting condition.

■ In case of "With Feedback (FB = ON)"

Assign P1 to P7 at the preset DI Input (DI2, DI3, DI4).

Switching from preset output to PID control output is made as a bumpless action (but within the proportional band).

■ In case of "Without Feedback (FB = OFF)"

Select either one of the followings at the preset DI Input (DI2, DI3, DI4).

- P1 Stop
- P2 Close action
- P3 Open action
- P4 to P7 Stop

Switching from preset output to PID control output is not made as a bumpless action.

■ In case of "DI Input = OFF"

PID control output is performed.

(4) Output limiter

Action under the MAN mode and Preset output may not be affected by the output limiter.

The action is as follows at PID control output.

In case of "With Feedback (FB = ON) ", output limiter is enabled.

In case of "Without Feedback (FB = OFF) ", output limiter is disabled.

(5) Servo Action

■ Control output value and position

- The motor position is controlled with control output value obtained through PID computation as the target position value with considering the dead band (DB).
- Output limiter (for details, refer to "10-7 Output Limit Value (OUT1L to OUT1H)") is for output value at PID control, but not for position limiter.
- In case of "With Feedback", the position of the control motor may be controlled by the output limiter.
- The interrelation among feedback potentiometer, motor nominal operative range, operative range after ZERO/SPAN adjustment, and output limiter is as follows:

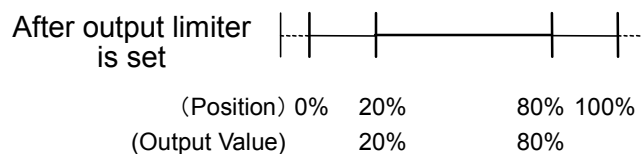
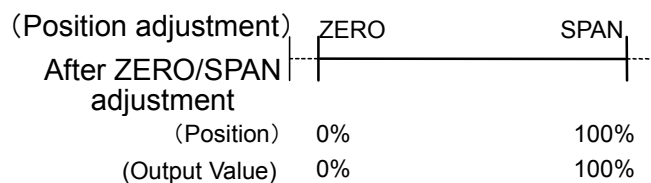
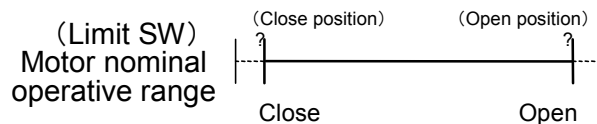
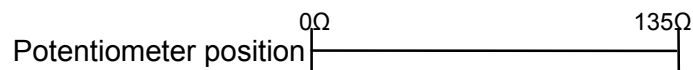

*Operative range by the output limiter (for details, refer to "10-7 Output Limit Value (OUT1L to OUT1H)") at lower limit = 20% and higher limit = 80%.

■ In case of "With Feedback"

Caution

- **Operation in case the wiring (R1) is open-circuited**
Position value becomes 0% or less (minus (-)) and Open signal is to be continuously output.
 - **Operation in case the wiring (R2) is open-circuited**
"ERROR" is indicated and becomes the output operation status selected at the output when the feedback potentiometer error is detected (POT. ERR).
 - **Operation in case the wiring (R3) is open-circuited**
Position value becomes 100% or larger and Close signal is to be continuously output.
-

■ In case of "Without Feedback"

The following action is taken when control output is continuously output at 0% or 100%.

At 0% Outputs Close signals for approx. 5% of the motor timing (TIME) every 30 seconds.

At 100% Outputs Open signals for approx. 5% of the motor timing (TIME) every 30 seconds.

(6) Interrelation between Dead Band (DB) and hysteresis

There is the following interrelation between dead band and hysteresis.

Hysteresis is one fourth ($1/4$) of Dead Band (DB).

If DB is less than 1.2%, hysteresis is fixed to 0.3%

If DB is equal to 0.2%, hysteresis is fixed to 0.2%

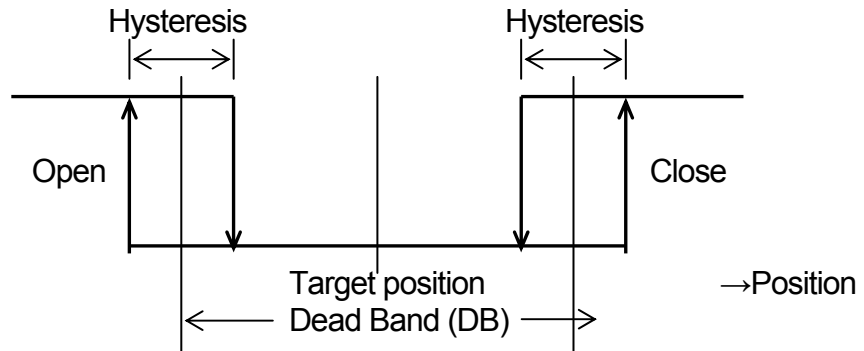

14 KEY LOCK SETTING

14-1 Setting Key Lock

(1) Displaying the key lock screen

To call up the LOCK, etc. screen group (group 8) from the basic screen, press the **GRP** key.

Press the **SCRN** key in the LOCK, etc. screen group to switch to the screens for making and changing setups.

Select parameters in screens by pressing the **↻** key.

Set parameters by pressing the **◀**, **▼** or **▲** key, and press the **ENT** key to fix and register settings.

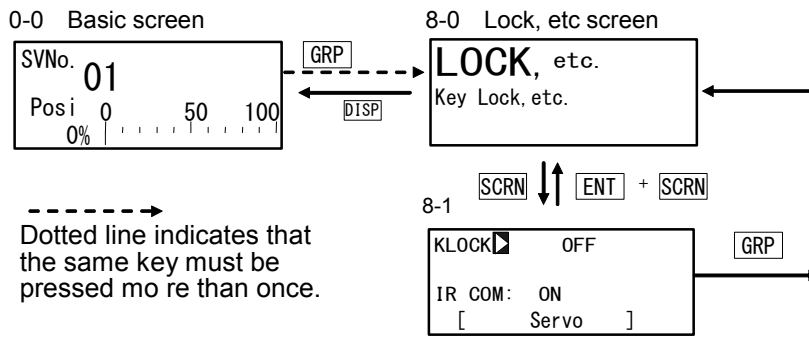

(2) Key lock

When the key lock is applied, **🔒** (key mark) is displayed at the relevant parameter on the LCD screen, and the parameter cannot be set or changed.

8-1		Setting range	OFF, LOCK1, LOCK2, LOCK3
		Initial value	OFF
	<div style="border: 1px solid black; padding: 5px;"> <p>KLOCK 🔒 OFF</p> <p>IR COM: ON</p> <p>[Servo]</p> </div>		

OFF Releases the key lock

LOCK1 Locks parameters other than SV related, AT, MAN, and EVENT/DO parameters.

LOCK2 Locks parameters other than SV related parameters

LOCK3 Locks all parameters (excluding the key lock parameter itself)

For details on parameters that are locked, see "18 List of Parameters."

This page left intentionally blank.

15 MONITORING, EXECUTING & STOPPING OPERATION

Various monitor functions are grouped in the basic screen group (group 0).

The configuration of this basic screen group, moving between screens and display details differ according to the specifications of the SR23 Series and selected options.

15-1 Flow of Basic Screen

(1) Control output (OUT1/Posi)

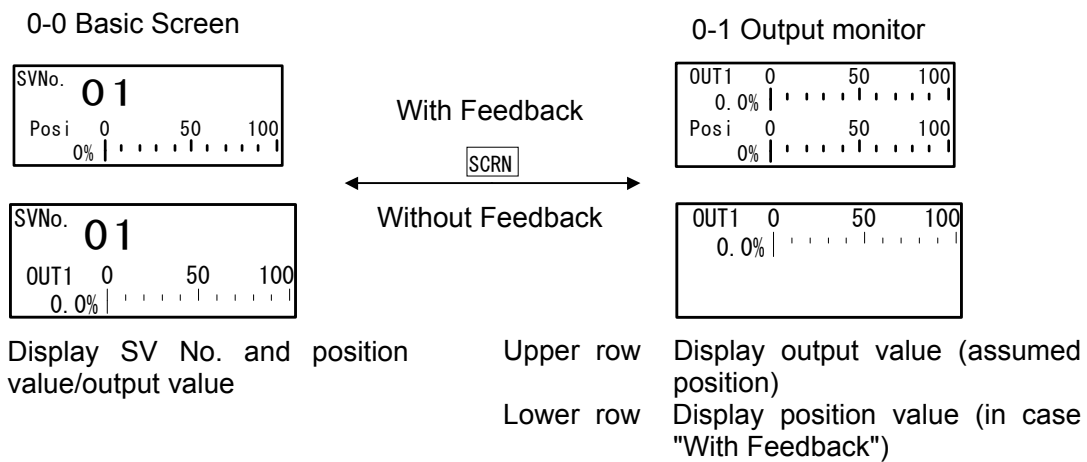

When used with Feedback, the output monitor displays OUT1 (control output) on the upper row and Posi (position value) on the lower row as a percentage (%) of the output value and a bar graph.

When OUT1 or Posi is highlighted, this means that the controller is in the Manual mode (MAN=ON).

For details about Manual mode, refer to "16-7 Setting Control Output (Man)".

(2) Output with preset value (Preset1 to 7)

In case preset value is assigned, the Basic screen (No. 0-0) information, Output monitor (No. 0-1) information, and controller's operation may be the following.

■ In case with feedback

Instead of OUT1, any from "Pre.1" to "Pre.7" will be displayed.

When the mode is switched to the Manual operation mode (MAN=ON), control using preset value is disabled, OUT1 value is displayed, and the operation for open output ON or close output ON may be available.

When returning the normal control mode from the Manual mode (MAN=OFF), OUT1 display is switched to preset value (any from Pre.1 to Pre.7), and the controller change to the state that is assigned to preset.

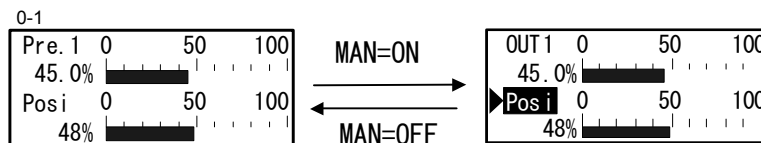

■ In case without feedback

Instead of OUT1, any from "Stop", "Close", "Open" will be displayed.

When the mode is switched to the Manual operation mode (MAN=ON), control using preset value is disabled, OUT1 value is displayed, and the operation for open output ON or close output ON may be available.

When returning the normal control mode from the Manual mode (MAN=OFF), OUT1 displays its status (any from Stop, Close, Open), and the controller change to the state that is assigned to preset.

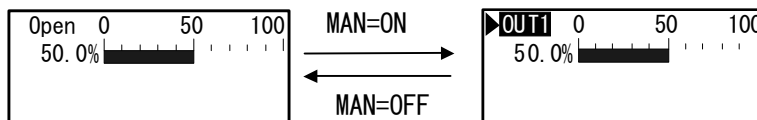

■ Operation when returning from Manual mode

When the Manual mode is set to OFF (MAN=OFF), the output operation is performed in order of the following precedence (the smaller number is the higher priority).

- (1) Manual output (top priority)
- (2) Output at feedback potentiometer error (in case of "with feedback")
- (3) Output at standby
- (4) Output with preset value
- (5) Output at error
- (6) PID control output

15-2 Operations in Basic Screen

(1) Switching the SV No.

You can switch the currently executing SV No. by the key, and set or change the currently executing SV value by the , and keys.

(2) Output monitor screen

The output monitor displays the outputs of Control Output 1 (OUT1) and position value (Posi) as a percentage (%) of the output values as a bar graph.

In the Manual Output mode, output values can be set or changed by the , and keys.

This page left intentionally blank.

16 OPERATIONS DURING CONTROL

16-1 Monitoring Control

(1) Basic screen

For flow of basic screen and operation, refer to "15-1 Flow of Basic Screen". The basic screen is "SV No., Position value display" or "SV No., Output value display".

(2) Output monitor

The output values of Control Output 1 (OUT1) and Position values (Posi) are displayed on the upper or the lower row respectively, as a % and a bar graph. Without feedback, Posi is not displayed.

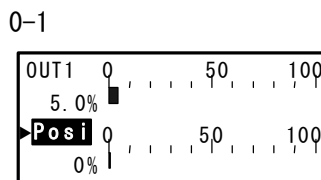

During manual output (when OUT1 or Posi is highlighted), open output or close output can be set to ON by operating the ◀ or ▲ key.

For details, see "13-1 Overview of Setup Procedure"

16-2 Switching the Execution SV No.

1. When you press the **[SV]** key in a screen display other than the basic screen, the basic screen is displayed, and the number of the SV No. blinks and can be changed.
2. When you press the **[SV]** key, the number of the SV No. is incremented and blinks, and can be changed.
3. The SV No. can be changed using the ▲ or ▼ key.
Also, pressing the **[SV]** key increments the number of the SV No.
4. When the number of the SV No. is fixed and registered by the **[ENT]** key, the number stops blinking.

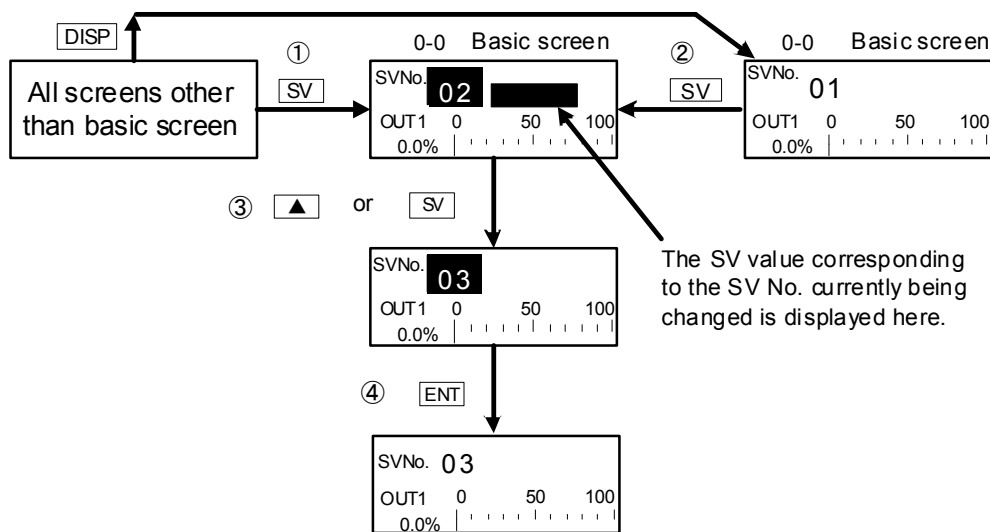

When SV No. switching is set to external switching (EXT_SV assigned to DI7 and EXT indicator lit), the SV No. cannot be changed using the keys on the front panel of this device.

16-3 Setting the Execution SV No.

Follow the procedure below to set or change the SV No. currently being executed.

1. When you press the , or key in the basic screen (0-0), the smallest digit of the SV display blinks, and the SV No. can be set or changed.
2. Press the key to move the blinking section on the numerical value to the digit to be changed, and change the SV No. using the or key.

To set or change not the currently executing SV value but an already set SV value, see "9-1 Setting the SV Value."

16-4 Externally Switching the SV No.

When two or more target set values (SV) are used, selection of the execution SV No. can be switched by an external contact.

Only DI7 to DI10 can be set.

This function can be used only when the optional external I/O control function is installed.

When EXT_SV is assigned to DI7, DI8 to DI10 automatically become the SV No. external switched assignments, and other functions can no longer be assigned.

5-3

DI5:	None
DI6:	None
DI7:	<input checked="" type="checkbox"/> EXT_SV
DI8:	<input type="checkbox"/> EXT_SV

Select the SV No. as shown in the table below and switch to this SV No. corresponding to the signal input of DI7 to DI10.

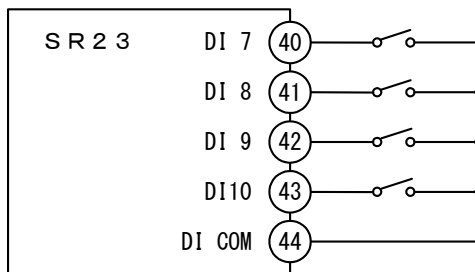

SV No. / DI No.	1	2	3	4	5	6	7	8	9	10
DI 7	●		●		●		●		●	
DI 8		●	●			●	●			●
DI 9				●	●	●	●			
DI 10								●	●	●

● Indicates that the switch is ON.

Note

- ◆ When there is no input to DI, SV No.1 becomes the execution SV.
- ◆ When there is a DI input corresponding to 11 or more, SV No.10 becomes the execution SV.
- ◆ When switching is performed, for example, by a decimal switch, sometimes an SV No. other than the expected SV No. is switched to momentarily at the moment that the contact is switched. Set DI on this device so that it is switched within the response time (100 ms).

16-5 Auto Tuning

(1) Executing and Stopping Auto Tuning

Select execution/stop of PID auto tuning (AT).

During execution of auto tuning, the optimum PID constants are calculated according to the limit cycle method, and those values are used to automatically perform control action. During execution of auto tuning, hunting caused by the limit cycle occurs near the SV value.

Hunting near the SV value can be prevented by setting the auto tuning point to perform auto tuning when the value leaves the SV value.

For details on setting this auto tuning point, see "10-9 Auto Tuning Point."

1-1

AT	<input checked="" type="checkbox"/>	OFF
MAN :		OFF
STBY:		OFF

Setting range ON, OFF

Initial value OFF

Auto tuning is executed when AT is set to ON.

During execution of auto tuning, the AT LED indicator blinks, lights during auto tuning standby, and goes out when auto tuning ends or stops.

When "AT execution/stop switching" is assigned to DI, auto tuning can be executed by external contacts, however, "AT execution/stop" by front key switches is not possible.

For execution of auto tuning, the following conditions must be satisfied.

These conditions are common to both front panel keys and external switch input.

- ◆ The mode must not be the manual output (MAN) mode.
- ◆ Execution of ramp control must not be in progress.
- ◆ P must not be set to OFF (ON-OFF control).
- ◆ The mode must not be standby (STBY: ON, action stopped).
- ◆ Remote SV must not be in use.
- ◆ The mode must not be PV zone PID.
- ◆ The PV value must not be causing the scale over error.
- ◆ Self-tuning must not be set.
- ◆ Preset is not output.
- ◆ The controller has not be causing the potentiometer error.

Note

- ◆ It is sometimes better to correct the PID obtained by auto tuning depending on the control target, control loop wasted time, and other factors.
- ◆ To use the output limit, set the lower limit and higher limit values of the control output value before execution of auto tuning.
- ◆ Auto tuning action is stopped in the following instances:
 - (1) When a scale over error occurs
 - (2) During a power failure
 - (3) When the ON or OFF time has exceeded about 200 minutes
 - (4) When the standby (STBY) mode is set

(2) Selecting the PID tuning mode

PID auto-tuning using the limit cycle method is the default tuning mode for Tuning.

3-22

Tuning <input checked="" type="checkbox"/> Auto Tuning Hunting: 0.5% AT Point: 0.0°C
--

Setting range	Auto Tuning, Self Tuning
Initial value	Auto Tuning

16-6 Self Tuning

Various restrictions are applied to use of self tuning.
For details on self tuning, see "16-10-2 Self tuning."

Select self tuning for Tuning.

3-22

Tuning <input checked="" type="checkbox"/> Self Tuning Hunting: 0.5% AT Point: 0.0°C
--

Setting range	Auto Tuning, Self Tuning
Initial value	Auto Tuning

Caution

- As the SR23 is a high-precision, high-function controller, use of the auto tuning (AT) function is recommended as optimum PID constants can be obtained more easily than by self tuning.
 - On the following types of control targets, self tuning sometimes does not function normally, inappropriate PID constants are calculated and set, and the optimum control result is not obtained. For this reason, do not use self tuning:
 - ◆ Control targets that cause cyclical external disturbance
 - ◆ Control target with extremely short or long dead band
 - ◆ When the measured value (PV value) contains noise and is unstable
 - In case it is used without feedback, the tuning mode is fixed to Auto Tuning.
-

16-7 Setting Control Output (MAN)

Select auto (AUTO)/manual (MAN) of control output.

Normally, operation is performed automatically. This item, however, is used to manually set the positioning during trial operation, for example.

During manual output, control the motor directly, and feedback control is not performed. Also, the MAN LED indicator blinks.

(1) Switching auto/manual

1-1

AT :	OFF
MAN <input checked="" type="checkbox"/>	OFF
STBY:	OFF

Setting range ON, OFF

Initial value OFF

The mode changes to the Manual Output mode when MAN (manual) row is selected by the cursor and ON is selected and registered.

When "AT control output auto/manual switching" is assigned to DI, auto/manual switching can be executed by external contacts.

(2) Output value

The output monitor displays OUT1 (control output) on the upper row and Posi (position value) on the lower row as a percentage (%) of the output value and a bar graph.

When used without feedback, Posi is not displayed.

0-1

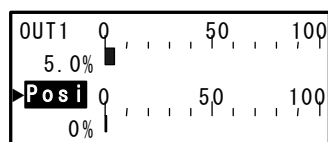

Under the Manual mode (when "OUT1" or "Posi" is highlighted), the output value which is indicated by a cursor can be set to open output ON/close output ON by the ▲ key or the ▼ key respectively.

(3) MAN key operations

This device is provided with a key exclusively for manual output so that you can switch to the output monitor screen (No. 0-1) by pressing the **MAN** key in any screen display. After displaying the output monitor screen, the simple manual output operation will be available with the following procedure.

■ Simple operation for OUT1/Posi

1. Press the **MAN** key to call up the output monitor screen.
2. Press the **▲** key or the **▼** key while holding down the **MAN** or the **ENT** key. The letters OUT1/Posi is highlighted to indicate that the mode is switched to the manual output (MAN = ON) mode.
3. Set open output ON/close output ON by the **▲** key or the **▼** key.
4. Press the **▲** key or the **▼** key again while holding down the **MAN** key or the **ENT** key. The mode setting returns to auto (MAN = OFF).

■ In case with feedback

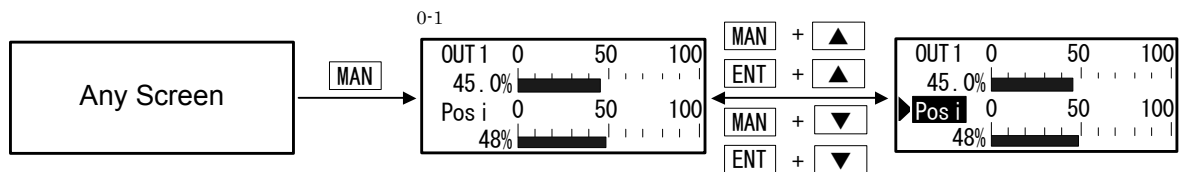

■ In case without feedback

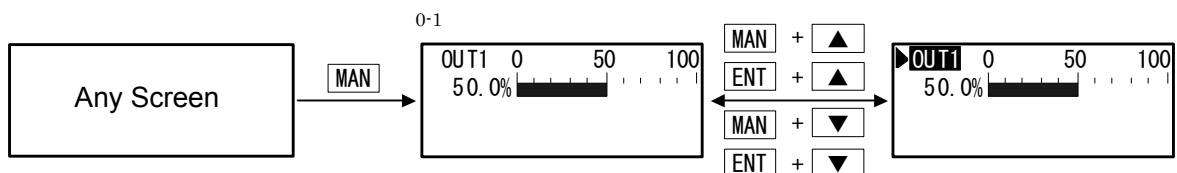

When the controller performs the auto tuning, it can switch to the Manual mode. However, auto tuning is stopped automatically when the mode is switched to Manual mode.

Note

When this device is turned OFF under the Manual mode (MAN=ON) and turned ON again, this device still starts up under the Manual mode.

16-8 Control Standby (STBY)

This function is used for stabilizing output values (for example, control output, event output, external output (DO)) before starting control.

Analog output acts regardless of the execution/standby setting.

In case it is used with feedback, it starts to control from specified preset position value or at "Stop".

In case it is used without feedback, it starts to control from "Stop", "Close" or "Open" which is specified in advance.

When it is used under the Standby mode, the STBY LED indicator blinks.

When "control execution/standby switching" is assigned to DI, execution/standby switching can be executed by external contacts.

1-1

AT	:	OFF
MAN	:	OFF
STBY	▣	OFF

Setting range OFF, ON

Initial value OFF

ON Control action is stopped, and control output becomes the preset output at standby (initial value 0%).

OFF Regular automatic control is performed.

For details on how to set output at standby, see "13-2 (2) Output at standby."

For details on preset position value, see "13-3 (2) Setting Servo preset value."

Note

When this device is turned OFF under the Standby Mode set (STBY=ON) and turned ON again, this device still starts up under the Standby Mode.

16-9 Pausing/Resuming Ramp Control (RAMP)

"Ramp control" is a function for not suddenly changing SV when it is switched but is a function for ensuring that SV changes according to a fixed ramp (rate-of-change).

This function enables this device to be used as a simple programmable controller.

Ramp control can be paused, resumed and aborted during execution.

During execution of ramp control (RAMP: RUN), the RMP LED indicator blinks, and lights when ramp execution is paused (PAUSE).

1-2

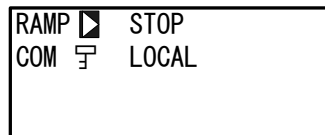
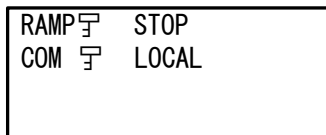

Setting range RUN,
 PAUSE,
 QUICK
 Initial value STOP

- STOP** STOP indicates that the ramp control is not executed. When the ramp control is not executed, this parameter cannot be changed.
- PAUSE** When RAMP control is executing (RAMP: RUN), and set to PAUSE, ramp control is paused, and control changes to fixed-value control using the execution SV value at that time. The RMP LED indicator lights.
- RUN** Paused ramp control can be resumed by RAMP: RUN setting.
 After ramp control is executed, the display changes to RAMP: RUN, the RMP LED indicator blinks, and the indicated SV No. changes towards to the target SV value.
 Start ramp control by switching the execution SV No.
- QUICK** Aborts ramp control, and immediately switches to the SV value of the target SV No.

For details on setting ramp control, see "9-5 Setting the Ramp."

16-10 Tuning Functions

This section describes the PID constant tuning functions.

Adjustment of PID constant (P: proportional band, I: integral time, D: derivative time) that are used in PID control is generally referred to as "tuning."

The SR23 Series supports the following two PID constant tuning methods:

1. Auto tuning (AT)
2. Self tuning

Caution

- As the SR23 is a high-precision, multi-function controller, use of the auto tuning (AT) function is recommended as optimum PID constants can be obtained more easily than by self tuning.
 - On the following types of control targets, self tuning sometimes does not function normally, inappropriate PID constants are calculated and set, and the optimum control result is not obtained. For this reason, do not use self tuning:
 - ◆ Control targets that have cyclical external disturbance
 - ◆ Control target with extremely short or long dead band
 - ◆ When the measured value (PV value) contains noise and is unstable
 - In case it is used without feedback, the tuning mode is fixed to Auto Tuning.
-

16-10-1 Auto tuning (AT)

■ System operation in Auto tuning

SR23 auto tuning is performed by the limit cycle method.

By this method, the control output is turned ON/OFF, to measure the amplitude and dead band of the measured value (PV), and calculate the PID constants.

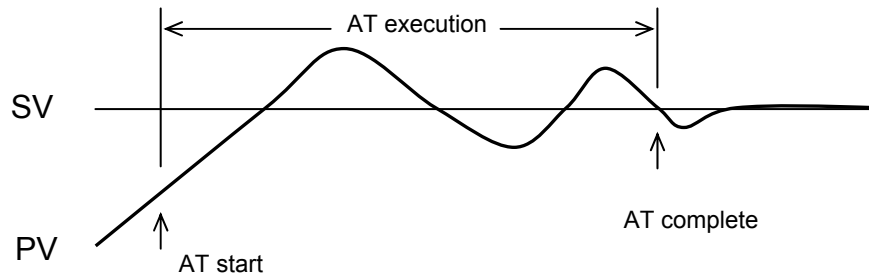

As the measured value is affected by the set value (SV), set auto tuning points (AT point) to prevent excessive measured values.

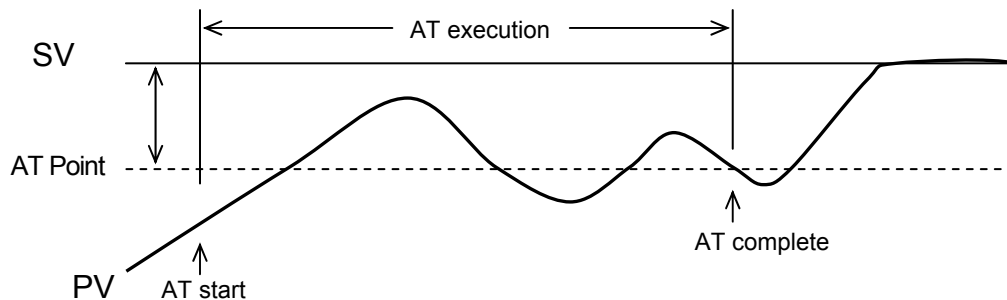

■ Conditions for starting up Auto tuning

- ◆ When [Tuning : Auto Tuning] is selected in the tuning screen, and AT is set ON (by front panel keys, DI input or communications)

■ Conditions for not starting up Auto tuning

- ◆ When standby operation (STBY) is being executed
- ◆ When output is manual output (MAN)
- ◆ When remote SV control (REM) is being executed
- ◆ When ramp control (RMP) is being executed
- ◆ When P=OFF (ON-OFF control)
- ◆ When PV zone PID is set
- ◆ When the PV value causes a scale over (SO) error
- ◆ When output is preset output
- ◆ When the controller has been causing the potentiometer error

■Canceling Auto tuning during execution

- ◆ By setting AT ON to OFF (by front panel keys, DI input, or communications)
- ◆ When 200 minutes is exceeded with the output value at the 0% or 100%
- ◆ During standby
- ◆ When the PV value causes a scale over (SO) error
- ◆ When output is preset output
- ◆ When the controller has been causing the potentiometer error
- ◆ During a power outage

Note

- ◆ Auto tuning sometimes is not performed correctly when the measured value (PV) contains noise and is unstable. Either stabilize the measurement input, or use a PV filter, for example, to stabilize the measured value before executing auto tuning.
 - ◆ When the output limiter is used, set the output limiter before execution of auto tuning. Note however, that control output operates between 0% to 100% (ON-OFF) regardless of the output limiter.
 - ◆ With some control targets, optimum PID constants are sometimes not obtained. If this happens, correcting the PID constants obtained by auto tuning may provide better results.
-

16-10-2 Self tuning

Self tuning is a function provided for performing tuning more easily than auto tuning. Self tuning is executed after tuning conditions are automatically judged. Two methods are provided on the SR23 self tuning:

1. Self tuning: step response (St)
2. Self tuning: hunting suppression (Hu)

These self tuning modes cannot be specified by users, as these are automatically selected by SR23.

(1) Self tuning: by step response (St)

■ System operation in step response

With self tuning by step response, timing is automatically performed by the step response method and PID constants are set by measuring fluctuations in the measured value (PV) when a fixed deviation and stable control output are being output, for example, when the power is turned ON, standby mode (STBY) is changed to execution (STBY OFF), or the setting value (SV) is changed.

Step response tuning

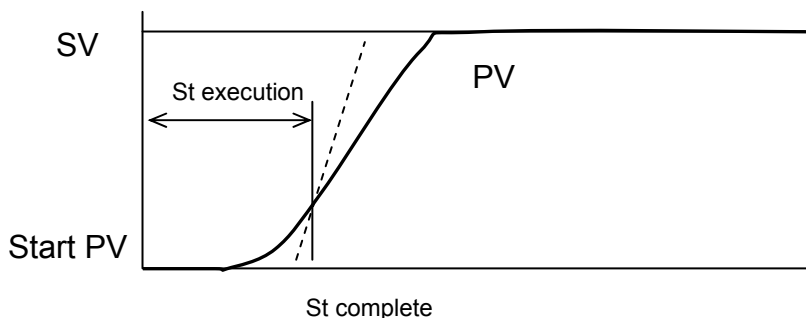

When self tuning by step response is started up, control computation is performed using the preset PID constants, and when tuning ends successfully, control computation is performed using the PID constants obtained and set by tuning.

Accordingly, when tuning is not to start up or is canceled, control computation will be continued using the PID constants set so far.

■ Conditions for starting up Self tuning

When [Tuning : Self Tuning] is selected in the tuning screen

- ◆ Immediately after power ON
- ◆ When standby (STBY) is changed to execution (STBY OFF)
- ◆ When the SV value is changed

■Conditions for not starting up Self tuning

- ◆ When it is used without feedback
- ◆ When standby operation (STBY) operation is being executed.
- ◆ When output is manual output (MAN).
- ◆ When ramp control (RMP) is being executed.
- ◆ When remote SV control (REM) is being executed.
- ◆ When output is preset output
- ◆ During potentiometer error
- ◆ When P = OFF (ON-OFF control)
- ◆ When the PV value causes a scale over (SO) error
- ◆ When zone PID is set
- ◆ When setting up the output rate-of-change limiter
- ◆ When step output (error between control output before and after startup) is 10% or less

■Conditions for canceling Self tuning by the step response

When the following operations are performed during self tuning by the step response, or conditions are satisfied, self tuning is canceled, and control is continued using the PID constants that were previously set:

- ◆ When the control characteristics (Reverse/Direct) are changed
- ◆ When the output limiter is changed
- ◆ When the control output is changed
- * As control is performed using the PID constants that were set when self tuning was set, in case the proportional band is large, and the deviation between the set value and the measured value is small, the control output will immediately fluctuate. For this reason, tuning becomes more likely to be canceled.
- ◆ When 10 hours have elapsed after tuning is started
- ◆ When the measured value fluctuates due to noise, etc., and it is judged that computation by the step response method is abnormal

Caution

- When the following conditions are not observed in self tuning by step response, accurate tuning results cannot be obtained, and inappropriate PID constants sometimes are calculated and set:
 - ◆ The control target and control loop must be operating correctly.
 - ◆ The measured value (PV) must be in a stable state when self tuning is started up. When measured values are fluctuating considerably, inappropriate PID constants may be calculated by executing self tuning.
 - ◆ The power of the motors such as heaters must be ON when self tuning is started up.
- If inappropriate PID constants are set, and stable control results cannot be obtained by the above conditions, perform the following to remedy this:
 - ◆ Correct the PID constants obtained by self tuning.
 - ◆ Execute auto tuning (AT).

(2) Self tuning: by hunting suppression (Hu)

■ System operation in hunting suppression

Hunting suppression tuning returns the measured value (PV) towards the stable direction when measured value causes hunting due to changes in the conditions of the control target.

Hunting suppression tuning

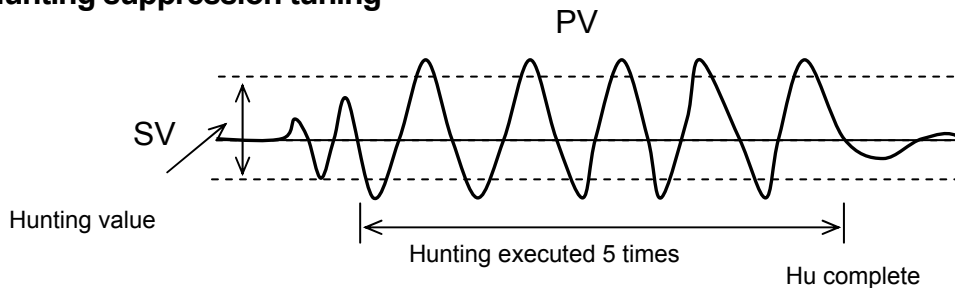

■ Conditions for starting up Self tuning

When [Tuning : Self Tuning] is selected in the tuning screen

- ◆ When the set value (SV) crosses ($\pm 0.02\%$ FS or more) and fluctuates vertically
- ◆ When vertical fluctuation is repeated at a Hunting value or more set in the tuning screen

■ Conditions for not starting up Self tuning

- ◆ When it is used without feedback
- ◆ When standby operation (STBY) operation is being executed
- ◆ When output is manual output (MAN)
- ◆ When ramp control (RMP) is being executed
- ◆ When remote SV control (REM) is being executed
- ◆ When output is preset output
- ◆ During potentiometer error
- ◆ When P = OFF (ON-OFF control)
- ◆ When the PV value causes a scale over (SO) error
- ◆ When zone PID is set
- ◆ When the output rate-of-change limiter is being executed
- ◆ During self tuning by step response

■ Tuning standby conditions

When the following conditions occur, operation stands by for desirable startup conditions to be generated:

- ◆ When the current fluctuation width attenuates (gets smaller) to 25% or less from the previous fluctuation width
- ◆ When the 5th fluctuation width attenuates (gets smaller) to 25% or less from the initial fluctuation width
- ◆ When the PID constants are changed
- ◆ When the control characteristics (Reverse/Direct) are changed
- ◆ When the output limiter is changed

The aim of hunting suppression tuning when hunting occurs is to suppress hunting that occurs when the PID constants do not match the actual control target (e.g. small P, small I, large D).

As the aim is to suppress vibration, when vibration is caused by cyclic external disturbance, for example, the PID constants may be slightly corrected (e.g. larger P, larger I), which might result in increased vibration.

If this happens, the PID constants must be adjusted by the following methods:

- ◆ Reduce cyclic external disturbance.
- ◆ Set up the PID constants by auto tuning (AT).

17 ERROR DISPLAYS

17-1 Operation Check Abnormalities at Power ON

This device displays the following error codes on the PV display when an error is detected.

Display	Cause	
<i>E - r o ñ</i>	ROM error	In any of the states shown on the left, all outputs turn OFF or become 0%.
<i>E - r A ñ</i>	RAM error	
<i>E - E E P</i>	EEPROM error	
<i>E - A d 1</i>	Input 1 A/D error	
<i>E - S P c</i>	Hardware error	

Request

- ◆ If any of the messages shown in the above table is displayed, repair or replacement may be required. Immediately turn the power OFF, and contact your dealer.

17-2 PV Input Abnormalities

When a PV input-related abnormality is detected during execution of control on this device, the following error codes are displayed on the PV display.

Display	Cause
<i>S c . L L</i>	The PV value exceeded the measuring range lower limit (-10%FS).
<i>S c . H H</i>	The PV value exceeded the measuring range higher limit (+110%FS).
	RTD-A burnout
	Thermocouple burnout
<i>b - - - -</i>	One or two RTD-B burnout, or, all leads of the RTDs burnout Action of this device in this case is PV moving excessively towards the higher limit.
<i>E J . L L</i>	Reference junction compensation (-20°C) is at the lower limit. (thermocouple input)
<i>E J . H H</i>	Reference junction compensation (+80°C) is at the higher limit. (thermocouple input)

17-3 REM Input Abnormalities

When an abnormality is detected in the REM input during execution of REM SV on this device, the following error codes are displayed on the PV display.

Display	Cause
<i>rE_LL</i>	REM input exceeds the input range lower limit.
<i>rE_HH</i>	REM input exceeds the input range higher limit.

Request

- ◆ Check input when the above messages are displayed. If the input is not in error and there is another probable cause, contact your dealer.
-

17-4 Feedback potentiometer error

When used with the feedback, and open-circuit of feedback potentiometer "R2" is detected, the following error code is displayed on the LCD.

Display	Cause
<i>Error</i>	Feedback potentiometer error

18 LIST OF PARAMETERS

This chapter lists all of the parameters used by the SR23.

Parameters that cannot be set by the user are not listed.

Display symbol	Indicates the parameter symbol displayed on the LCD screen.
Description of function	Indicates the display or setup details.
Setting range	Indicates the range of parameters or numerical values that can be set.
Initial value	Indicates the factory setting. (excluding instances where this device is shipped with values customized to customer specified values)
Lock	Number indicates the level at which key lock is valid.

* Indicates a parameter that may be initialized when one of a range setting, unit setting or PV scaling setting has been changed.

Parameters marked by * may need to be confirmed again when the above settings have been change.

18-1 Basic Screen Group (group 0)

Display Symbol	Description of Function	Setting Range	Initial Value	Lock
SV No.	Target set value No.	1 to 10, REM	1	2
OUT1	OUT1 output value	0.0 to 100.0 %	---	1
Posi	Position value	0 to 100 %	---	1

18-2 Execution Screen Group (group 1)

Display Symbol	Description of Function	Setting Range	Initial Value	Lock
AT	Execution of auto tuning	OFF : Stop auto tuning ON : Execute auto tuning	OFF	2
MAN	Switching of manual output action	OFF : Automatic control ON : Manual output	OFF	2
STBY	Standby switching	OFF : Execute ON : Standby	OFF	2
RAMP	Ramp control	STOP : Execution OFF PAUSE : Execution paused RUN : Execution continued	STOP	2
COM	Communication state	LOCAL : Set on unit COMM : Set by communication	LOCAL	2

18-3 SV Setup Screen Group (group 2)

Display Symbol	Description of Function	Setting Range	Initial Value	Lock
SV1 *	Target set value 1	Within setting limiter range	0 or value of lower limit side of the measuring range, whichever is larger	3
SV2 *	Target set value 2			
SV3 *	Target set value 3			
SV4 *	Target set value 4			
SV5 *	Target set value 5			
SV6 *	Target set value 6			
SV7 *	Target set value 7			
SV8 *	Target set value 8			
SV9 *	Target set value 9			
SV10 *	Target set value 10			
REM	Remote monitor	Within remote scale range (display only)		
SV Limit_L *	Target set value lower limit value limiter	Within measuring range	Measuring range lower limit value	1
SV Limit_H *	Target set value upper limit value limiter	Within measuring range	Measuring range upper limit value	1
REM Track	Remote tracking	NO YES	NO	1
REM Mode *	Remote mode	RSV : Remote SV RT : Remote ratio	RSV	1
REM Ratio *	Remote ratio	0.001 to 30.000	1.000	1
REM Bias *	Remote bias	-10000 to 10000 digit	0 digit	1
REM Filt	Remote filter	OFF, 1 to 300 Sec	OFF	1
REM Sc_L *	Lower limit side remote scale	Within measuring range	Measuring range lower limit value	1
REM Sc_H *	Higher limit side remote scale	Within measuring range	Measuring range higher limit value	1
REM PID	Remote SV PID No.	1 to 10	1	1
REM SQ. Root	Remote square root extraction operation	OFF ON	OFF	1
REM Low Cut	Remote square root extraction operation low cut	0.0 to 5.0%	1.0%	1
RAMP Up *	Ascending ramp value	OFF, 1 to 10000 digit	OFF	1
RAMP Down *	Descending ramp value	OFF, 1 to 10000 digit	OFF	1
RAMP Unit	Ramp unit	/Sec /Min	/Sec	1
RAMP Ratio	Ramp ratio	/1 /10	/1	1

18-4 PID Screen Group (group 3)

Display Symbol		Description of Function	Setting Range	Initial Value	Lock	
PID01	OUT1	P	Proportional band	OFF, 0.1 to 999.9 %	3.0 %	1
PID02		I	Integral time	OFF, 1 to 6000 sec	120 sec	1
PID03		D	Derivative time	OFF, 1 to 3600 sec	30 sec	1
PID04		DF *	Hysteresis	1 to 9999 digit	20 digit	1
PID05		MR	Manual reset	-50.0 to 50.0 %	0.0 %	1
PID06		SF	Set value function	0.00 to 1.00	0.40	1
PID07		ZN *	PID zone	Within measuring range	0 digit	1
PID08						
PID09		OUT1L	Output limit lower limit value (OUT1)	0.0 to 99.9 %	0.0 %	1
PID10						
	OUT1H	Output limit higher limit value (OUT1)	0.1 to 100.0 %	100.0 %	1	
Zone	PID1	OUT1 zone PID mode	OFF SV : SV zone selection PV : PV zone selection	OFF	1	
	HYS1 *	OUT1 zone hysteresis	0 to 10000 digit	20 digit	1	
REM PID		Remote SV PID No.	1 to 10	1	1	
Tuning		Tuning mode	Auto Tuning Self Tuning	Auto Tuning	1	
Hunting		Hunting	0.1 to 100.0%	0.5%	1	
AT Point *		Auto-tuning point	0 to 10000 digit	0 digit	1	

18-5 EVENT/DO Screen Group (group 4)

Display Symbol		Description of Function	Setting Range	Initial Value	Lock
EV1 EV2 EV3 DO1 DO2 DO3 DO4 DO5 DO6 DO7 DO8 DO9	SP*	Operation value	-25000 to 25000 digit (DEV Hi, DEV Low) 0 to 25000 digit (DEV Out, DEV In)	DEV Hi : 25000 digit DEV Low : -25000 digit DEV Out : 25000 digit DEV In : 25000 digit	2
			Within measuring range (PV)	PV Hi : Measuring range higher limit value PV Low: Measuring range lower limit value	
			Within SV setting range (SV)	SV Hi : Higher limit value of SV SV Low : Lower limit value of SV	
			0 to 100%	Posi.H : 100% Posi.L : 0%	
	MD	Operation mode	None : No action DEV Hi : Higher limit deviation action DEV Low : Lower limit deviation action DEV Out : Outside higher/lower limit deviation action DEV In : Inside higher/lower limit deviation action PV Hi : PV higher limit absolute value action PV Low : PV lower limit absolute value action SV Hi : SV higher limit absolute value action SV Low : SV lower limit absolute value action AT : Auto tuning execution in progress MAN : Manual action in progress REM : Remote action in progress RMP : Ramp control execution in progress STBY : Control action not in progress SO : PV, REM input scale over PV SO : PV scale over REM SO : REM scale over LOGIC : Logic operation output (EV1 to EV3, DO1 to DO5) (*1 *2) Direct : Direct output (DO6 to DO9) (*3) Posi.H : Position higher limit absolute value Posi.L : Position lower limit absolute value POT.ER : Feedback potentiometer error	EV1: DEV Hi EV2: DEV Low EV3: None DO1 to DO9: None (*4)	1

Display Symbol		Description of Function	Setting Range	Initial Value	Lock
EV1 EV2	ACT	Output characteristics	N.O.: Normally open N.C.: Normally closed	N.O.	1
EV3	DF*	Hysteresis	1 to 9999 digit	20 digit	1
DO1 DO2 DO3 DO4 DO5 DO6 DO7	IH	Standby action	OFF : None 1 : At power ON or at STBY ON -> OFF 2 : At power ON, at STBY ON -> OFF or SV change 3 : At input error	OFF	1
DO8	DLY	Delay time	OFF, 1 to 9999 Sec	OFF	1
DO9	STEV	Event output at standby	OFF ON	OFF	1
EV1 EV2 EV3	Log MD	Logic operation mode	AND OR XOR	AND	1
DO1 DO2 DO3	SRC1	Logic operation source 1	None, DI1 to DI10	None	1
	SRC2	Logic operation source 2		None	1
	Gate1	Logic operation gate source 1	BUF INV FF	BUF	1
	Gate2	Logic operation gate source 2		BUF	1
DO4 DO5	Timer	Timer (action time)	OFF, 1 to 5000 Sec	OFF	1
	Counter	Counter (action count)	OFF, 1 to 5000	OFF	1
	SRC	Logic operation generation source selection	DI1 to DI10	None	1
	Log_MD	Logic operation mode	Timer Counter	Timer	1

*1 Logic operation (AND, OR, XOR) can be assigned only to LOGIC EV1 to EV3, and DO1 to DO3.

*2 Logic operation (Timer, Counter) can be assigned only to DO4 and DO5.

*3 Direct output can be assigned only to DO6 to DO9 with communication interface option.

*4 DO6 to DO9 are optional and not displayed when they are not installed.

*5 Posi.H, Posi.L, or POT.ER can be assigned when feedback potentiometer is used.

18-6 DI/Options Screen Group (group 5)

Display Symbol	Description of Function	Setting Range	Initial Value	Lock
DI1	DI1 assignment	None : No action (factory default)	None	1
DI2	DI2 assignment	MAN : Switching of control output between auto/manual		
DI3	DI3 assignment	REM : Switching of REM SV/LOC SV setting.		
DI4	DI4 assignment	AT : Switching of AT execution/stop		
DI5	DI5 assignment	STBY : Switching of control execution/standby		
DI6	DI6 assignment	ACT : Switching of direct/reverse action on Output 1 characteristics		
DI7	DI7 assignment	Pause : Switching of pause/resume of ramp control		
DI8	DI8 assignment	Logic : Logic operation		
DI9	DI9 assignment	Preset 1 : Only DI2 can be set (assigned to DI2)		
DI10	DI10 assignment	Preset 2 : Only DI2 can be set (assigned to DI2 to DI3) Preset 3 : Only DI2 can be set (assigned to DI2 to DI4) EXT_SV : External switching of SV No. Only DI7 can be set (assigned to DI7 to DI10).		
Ao1 Ao2	MD Analog output type assignment	PV : Measured value SV : Set value DEV : Deviation value OUT1 : Control Output 1 Posi : Position output value	PV (Ao1) SV (Ao2)	1
	_L * Analog output lower limit scaling	PV, SV : Within setting range DEV : -100.0 to 100.0% OUT1 : 0.0 to 100.0%	Setting range lower limit value	1
	_H * Analog output higher limit scaling	Posi : 0 % to 100%	Setting range higher limit value	1

Note DI5 to DI10 and Ao1MD to _H are optional and are not displayed when they are not installed.

18-7 Communication (group 5)

Display Symbol	Description of Function	Setting Range	Initial Value	Lock
PROT	Communication protocol	SHIMADEN : Shimaden MOD_ASC : Modbus ASCII MOD_RTU : Modbus RTU	SHIMADEN	1
ADDR	Device No.	1 to 98	1	1
BPS	Communication speed	2400 4800 9600 19200	9600	1
MEM	Memory mode	EEP RAM R_E	EEP	1
DATA	Data length	7 8	7	1
PARI	Parity	EVEN ODD NONE	EVEN	1
STOP	Stop bit	1 2	1	1
DELY	Delay time	1 to 50 msec	10 msec	1
CTRL (*1)	Control	STX_ETX_CR STX_ETX_CRLF @ : _CR	STX_ETX_CR	1
BCC (*1)	Checksum	ADD ADD_two's cmp XOR None	ADD	1

*1: SHIMADEN standard protocol only

Note Parameters belong to communication group are optional and are not displayed when they are not installed.

18-8 Control Output Screen Group (group 6)

Display Symbol		Description of Function	Setting Range	Initial Value	Lock
OUT1	ACT	Output characteristics	Reverse: Reverse characteristics Direct : Direct characteristics	Reverse	1
	STBY	Output at standby	With FB: Stop, Preset1 to 7 Without FB: Stop, Close Open	w FB: Preset1 w/o FB: Close	1
	ERR	Output at error	With FB: Stop, Preset1 to 7 Without FB: Stop, Close Open	w FB: Preset1 w/o FB: Close	1
	POT.ERR	Feedback potentiometer error	With FB (only): Stop, Close, Open	Stop	1
Rate Limiter	OUT1	Output 1 rate-of-change limiter	OFF, 0.1 to 100.0 %/s	OFF	1
Servo	FB	Feedback potentiometer	ON : with feedback potentiometer OFF: without feedback potentiometer	ON	1
	DB	Dead band	0.2 to 10.0 %	2.0 %	1
	Time	Motor timing	Without FB (only): 5 to 300s	60s	1
	BOOT	Action on start up	Without FB (only): Stop, Close, Open	Close	1
Servo calibration	MD	Mode for ZERO/SPAN adjustment	Auto: Automatic control Manual: Manual control	Auto	1
	EXE	Execution of ZERO/SPAN adjustment	Stop Start	Stop	1
	ZERO	ZERO adjustment manually	Open Close	--	1
	SPAN	SPAN adjustment manually	Open Close	--	1
Servo preset	P1 P2 P3 P4 P5 P6 P7	Servo preset values	0 to 100%	0%	1

Note FB stands for feedback potentiometer.

18-9 Unit/Range Screen Group (group 7)

Display Symbol	Description of Function	Setting Range	Initial Value	Lock
PV Bias *	PV bias	-10000 to 10000 digit	0 digit	1
PV Filter	PV ramp bias	OFF, 1 to 100 s	OFF	1
PV Slope * (*1)	PV filter	0.500 to 1.500	1.000	1
RANGE	Measuring range	01 to 19 TC 31 to 44 RTD Pt100 45 to 58 RTD old JIS JPt100 71 to 77 Voltage (mV) 81 to 87 Voltage (V)	06	1
Sc_L *	Input lower limit side scale	-19999 to 29990 digit	0 digit	1
Sc_H *	Input higher limit side scale	-19989 to 30000 digit	1000 digit	1
UNIT *	Measurement digit	RTD, TC: °C, °F I/V: %, °C, °F, None	RTC,TC: °C I/V: %	1
DP *	Decimal point position	XXXXX. XXXX.X XXX.XX XX.XXX X.XXXX	XXXX.X	1
Figure * (*2)	Selection of number of digits past decimal point	Normal Short	Normal	1
CJ (*3)	Cold junction compensation	Internal External	Internal	1
SQ. Root * (*4)	Square root extraction operation (at linear input)	OFF ON	OFF	1
Low Cut (*5)	Square root extraction operation low cut	0.0 to 5.0 %	1.0 %	1
PMD (*4)	Linearizer operation mode	OFF ON	OFF	1
A1 to A11 (*4)	Linearizer approximation input	-5.0 to 105.0 %	0.00 %	1
B1 to B11 (*4)	Linearizer approximation output	-5.0 to 105.0 %	0.00 %	1

*1 This screen is not displayed in the case of RTD and TC input.

*2 This screen is not displayed in the case of voltage and current input.

*3 This screen is displayed only in the case of TC input.

*4 This screen is displayed only in the case of voltage and current input.

*5 This screen is displayed only in the case of "square root function = ON".

18-10 Lock, etc Screen Group (group 8)

Display Symbol	Description of Function	Setting Range	Initial Value	Lock
KLOCK	Key lock	OFF : Release LOCK1: Other than SV, CONTROL LOCK2: Other than SV LOCK3: All	OFF	
IR COM	Infrared communications	ON : Enabled OFF : Disabled	ON	1

19 PARAMETER SETUP RECORD SHEETS

Lots of parameters are set on this device before use.

Users will find these sheets will come in handy to restore a system in the event of a malfunction, for example, if they keep a detailed record of the product model No. they are using and the values set on this device.

We recommend that you fully utilize these record sheets by making a blank copy of these tables and entering the required values on the copied record sheet.

19-1 Product Model Code

SR23-	MS	□N-	□□	□	□	□	□	□

19-2 SV Parameters

SV No.	Set Value
1	
2	
3	
4	
5	
6	
7	
8	
9	
10	

Item	Set Value
SV Limit_L	
SV Limit_H	
REM Track	
REM Mode	
REM Ratio	
REM Bias	
REM Filter	
REM Sc_L	
REM Sc_H	
REM PID	
REM SQ Root	
REM Low Cut	
RMP UP	
RMP Down	
RMP Unit	
RMP Ratio	

19-3 PID Parameters

OUT1

PID No.	P	I	D	DF	MR	SF	Zone	OUT1L	OUT1H
01									
02									
03									
04									
05									
06									
07									
08									
09									
10									

Zone PID

Item	Set Value
Zone PID1	
Zone HYS1	

Tuning

Item	Set Value
Tuning	
Hunting	
AT Point	

19-4 EVENT/DO Parameters

Item	EV1	EV2	EV3	DO1	DO2	DO3
SP						
MD						
ACT						
DF						
IH						
DLY						
STEV						
Log MD						
SRC1						
GATE1						
SRC2						
GATE2						

Item	DO4	DO5	DO6	DO7	DO8	DO9
SP						
MD						
ACT						
DF						
IH						
DLY						
STEV						
Log MD			---	---	---	---
SRC			---	---	---	---
Timer /Counter			---	---	---	---

19-5 DI/Options Parameters

Item	Set Value
DI1	
DI2	
DI3	
DI4	
DI5	
DI6	
DI7	
DI8	
DI9	
DI10	
Ao1MD	
Ao1 L	
Ao1 H	
Ao2MD	
Ao2 L	
Ao2 H	

Item	Set Value
COM PROT	
ADDR	
BPS	
MEM	
DATA	
PARI	
STOP	
DELY	
CTRL	
BCC	

19-6 Control Output Parameters

Item	Set value
ACT	
STBY	
ERR	
POT.ERR	
Rate Limiter	
SERVO FB	
DB	
TIME	
BOOT	
SERVO Calibration	
MD	
EXE	
ZERO	
SPAN	

Item	Set value
SERVO Preset	
P1	
P2	
P3	
P4	
P5	
P6	
P7	

19-7 Unit Measuring Range Parameters

Input settings

Item	Set Value
PV Bias	
PV Filter	
PV Slope	
RANGE	
Sc_L	
Sc_H	
UNIT	
DP	
Fig	
CJ	
SQ. Root	
Low Cut	
PMD	

PMD set values

PMD No.	Set Value		
	n	An	Bn
1			
2			
3			
4			
5			
6			
7			
8			
9			
10			
11			

19-8 Lock, etc. Parameters

Item	Set Value
KLOCK	
IR COM	

20 SPECIFICATIONS

20-1 Display

- ◆ **LED display** Measured value (PV) :7-segment red LED 5 digits, height of characters 16 mm
Set value (SV) :7-segment green LED 5 digits, height of characters 11 mm
- ◆ **LCD display** SV No., OUT% graph, control output value, various parameter displays
128 x 32 dot matrix liquid crystal display with yellow-green LED backlight
- ◆ **Action display lamps**
17 action statuses display. Lights, blinks, or turns off depend upon its status

STBY	Green	Blinks when control output is set to standby (STBY=ON)
RMP	Green	Blinks during execution of ramp control, and lights during ramp control is paused
MAN	Green	Blinks when control output is set to manual operation
REM	Green	Lights when remote setting (REM) is set in SV No. selection
EV1 to EV3	Orange	Lights when each EV acts
DO1 to DO5	Orange	Lights when each DO acts
EXT	Green	Lights when SV No. can be selected by external switch
COM	Green	Lights when communication mode is ON
AT	Green	Blinks during execution of auto tuning or lights during holding of auto tuning
OPEN	Green	Lights when open output is ON
CLOSE	Green	Lights when close output is ON
- ◆ **Display accuracy** ± (0.1% + 1digit) of measuring range (See Measuring Range Code Table for individual ranges.)

TC input	± (0.1% FS + 1°C)
Pt input	± (0.1% FS + 0.1°C)
mV, V input	± (0.1% FS + 1 digit)
mA input	Depends on accuracy of externally attached resistor (When ±0.1%FS accuracy is required, specify when ordering)
- ◆ **Temperature range for maintaining display accuracy**
23°C±5°C
- ◆ **Display resolution** 0.0001, 0.001, 0.01, 0.1, 1 (differs depending on measuring range)
- ◆ **Sampling cycle** 0.1 seconds (100 msec)

20-2 Setting

- ◆ **Local setting**
 - By 10 front panel key switches
 - Setting range Same as the measuring range
 - Multi-SV value setting
 - Up to 10 points (SV1 to SV10) settable
 - Multi-SV value selection
 - Front panel key switches or external control input (binary code) (when DI option is selected)
- ◆ **Remote setting**
 - By external analog signals, not insulated (standard)/insulated (option)
 - Setting accuracy $\pm(0.1\% \text{ FS} + 1 \text{ digit})$
 - Setting signal 0 to 10V, 1 to 5V, 4 to 20 mA DC (selectable from code selection table)
 - Sampling cycle 0.2 seconds (200 msec)
 - Remote scaling Possible within measuring range (reverse scaling possible)
 - Remote bias ± 10000 digit
 - Remote filter OFF, 1 to 300 seconds
 - Remote square root Low cut range 0.0 to 5.0% FS (at mV, V)
 - Remote ratio 0.001 to 30.000
 - Local/remote switching
 - Front panel key switches or external control input
 - Direct tracking function
 - Remote set value switchable to local set value by bumpless transfers
- ◆ **Ramp control**
 - Increment/decrement ramp control
 - Ramp value setting range
 - Ascending/descending individual setting
 - OFF, 1 to 10000 digit /minutes or seconds (when multiplier = 1)
 - OFF, 0.1 to 1000.0 digit /minutes or seconds (when multiplier = 0.1)
 - Ramp unit time Unit/seconds, unit/minutes
 - Ramp unit multiplier x 1, x 0.1
- ◆ **Higher/lower limit setting limiter**
 - Any value set within measuring range (lower limit < higher limit)

20-3 Input

- ◆ **Universal-input, multi-range**
Thermocouple input, RTD input, voltage input (mV, V), current input (mA),
- ◆ **Thermocouple (TC) input type**
B, R, S, K, E, J, T, N, PLII, PR40-20, WRe5-26, {L, U (DIN43710) }
AuFe-Cr (Kelvin scale).
For details, see Measuring Range Code Table
- Display range $\pm 10\%$ of measuring range
- Allowable range of external resistance
100 Ω max.
- Input resistance Approx. 500 k Ω
- Cold junction compensation
Selectable between internal and external cold junction compensation
- Internal cold junction compensation accuracy
 $\pm 1^\circ\text{C}$ (in range of 18 to 28 $^\circ\text{C}$)
- Burnout functions Standard feature (up scale)
- ◆ **RTD input type** JIS Pt100 / JPt100 3-wire type. For details, see Measuring Range Code Table
- Display range $\pm 10\%$ of measuring range (not lower than -273.15 $^\circ\text{C}$)
- Lead wire tolerance 10 Ω max. per wire
- Amperage Approx. 1.1mA
- ◆ **Voltage (mV, V)**
input type -10 to 10, 0 to 10, 0 to 20, 0 to 50, 10 to 50, 0 to 100, -100 to 100 mV
-1 to 1, 0 to 1, 0 to 2, 0 to 5, 1 to 5, 0 to 10, -10 to 10 V
Universal-input, programmable scaling
For details, see Measuring Range Code Table
- Input resistance Approx. 500 k Ω .
- ◆ **Current (mA)**
Input type 4 to 20, 0 to 20 mA: Universal-input and programmable scaling by receiving
resistance to 0 to 5, 1 to 5 V inputs
- Receiving resistance
250 Ω by external resistance
- ◆ **Common functions**
Sampling cycle 0.1 seconds (100 msec)
- PV bias ± 10000 digit
- PV slope Input value x 0.500 to 1.500
- PV filter OFF, 1 to 100 seconds
- ◆ **Input operation** Possible with voltage or current input
- Square root extraction operation
Low cut range 0.0 to 5.0% FS
- Linearizer approximation
Number of input points: 11
- ◆ **Isolation**
Insulated between input and DI input, or input and various outputs
Not insulated between input and the system, input and remote input

20-4 Control

(1) Control output

◆ Control system

	W/ auto tuning function, Expert PID control
Multi-PID	By PID Nos.01 to 10 (10 types) Individual PID set on each SV No. (and remote SV)
Zone PID	Selectable between individual PID and zone PID (max. 10 zones)
Proportional band (P)	OFF, 0.1 to 999.9% (OFF: ON-OFF action)
Integral time (I)	OFF, 1 to 6000 seconds (OFF: P or PD control)
Derivative time (D)	OFF, 1 to 3600 seconds (OFF: P or PI control)
Manual reset (MR)	-50.0 to 50.0% (available when I = OFF)

◆ Self tuning

Selectable from Auto tuning or self tuning, by step response system

◆ Operation update cycle

0.1 seconds (100 msec)

◆ Control output characteristics

Reverse (for heating)/Direct (for cooling)

◆ Higher/lower output limiter setting range

Higher limit/lower limit

Setting range 0.0 to 100.0% (lower limit < higher limit)

◆ Output rate-of-change limiter

OFF, 0.1 to 100.0%/seconds

(2) Servo output

◆ Control output

Output for servo actuator drive
Support for both feedback potentiometer with/without

◆ Control output type/rating

R: Contact output, Contact rating 240V AC 2A
Y: Contact output, Contact rating 240V AC 2A, built-in CR absorber

◆ Output update cycle

50msec

◆ Control output at error

Stop, Preset (0 to 100%) (with feedback potentiometer)

Stop, Close, Open (without feedback potentiometer)

◆ Control output at standby

Stop, Preset (0 to 100%) (with feedback potentiometer)

Stop, Close, Open (without feedback potentiometer)

◆ Output at potentiometer error

Stop, Close, Open (with feedback potentiometer)

◆ Manual control

Auto/manual switching

Balanceless/bumpless transfers (with feedback potentiometer)

Manual output Open/Close output

◆ Position Display

With percentage, as numerically and bar graph on LCD.

Display resolution 1%

Display range -10 to 110%

◆ Positioning zero/span adjustment

Supports automatic adjustment, Manual adjustment available

◆ Dead Band (DB)

0.2 to 10.0% of input signal

◆ Hysteresis (DF)

25% of the DB

When DB is equal to or lower than 1.2%, fixed to 0.3%.

◆ Feedback potentiometer

100 to 2kΩ /3 wire system

◆ Isolation

Insulated between Servo output and various I/O, and Servo Output and the system

20-5 Event Output

- ◆ **Number of outputs** Total 3: EV1 to EV3
 - ◆ **Output rating** 240V AC/1.0A resistive load, common to contact outputs (normally open contacts)
 - ◆ **Output update cycle** 0.1 seconds (100 msec)
 - ◆ **Setting/selection** Individual setting (individual output), selectable (to designate output)
 - Output types
 - 1) None No action (no assignment)
 - 2) DEV Hi Higher limit deviation alarm
 - 3) DEV Low Lower limit deviation alarm
 - 4) DEV Out Outside higher/lower limit deviation alarm
 - 5) DEV In Inside higher/lower limit deviation alarm
 - 6) PV Hi PV higher limit alarm
 - 7) PV Low PV lower limit alarm
 - 8) SV Hi SV higher limit alarm
 - 9) SV Low SV lower limit alarm
 - 10) AT ON during execution of auto tuning
 - 11) MAN ON during manual control operation
 - 12) REM ON while remote SV is in action
 - 13) RMP ON while ramp control is in action
 - 14) STBY ON while control is out of action
 - 15) SO ON when PV and REM scale over error occurs
 - 16) PV SO ON when PV scale over error occurs
 - 17) REM SO ON when REM scale over error occurs
 - 18) LOGIC ON during logic operation output by DI or communication
 - 19) Direct ON during Direct output by communication
 - 20) Posi.H Position higher limit absolute value
 - 21) Posi.L Position lower limit absolute value
 - 22) POT.ER ON during feedback potentiometer error
- Direct cannot be set for events, but for DOs.
Posi.H, Posi.L, or POT.ER can be set when the controller is used with a feedback potentiometer.
- ◆ **Setting range**
 - DEV Hi, Low -25000 to 25000 digit
 - DEV Out, In 0 to 25000 digit
 - PV, Hi, Low Within measuring range
 - SV, Hi, Low Within the setting range of SV
 - Posi.H, Posi.L 0 to 100%
 - Hysteresis 1 to 9999 digit (when DEV, PV, SV or Posi is selected)
 - Action delay time OFF, 1 to 9999 seconds (when DEV, PV, SV or Posi is selected)
 - Standby action Selectable from 3 types (when DEV, PV, SV or Posi is selected)
 - OFF, no standby action
 - 1) At power ON, or at STBY ON→ OFF
 - 2) At power ON, at STBY ON→ OFF, or at execution SV is changed
 - 3) At input error (SO), when action is OFF
 - Output characteristics switching Selectable between normally open and normally closed
 - ◆ **Isolation** Insulated between event output and various I/O, or event output and the system

20-6 External Control Output (DO)

- ◆ **Number of outputs** 9 or 5 points in total: standard 5 and 4 can be added optionally
 - DO1 to DO3 Darlington output 3 points
 - DO4 to DO5 Open collector output 2 points
 - DO6 to DO9 Open collector output 4 points (optional)
- ◆ **Output rating** Open collector output 24 V DC/8 mA max., ON voltage 0.8 V or lower
Darlington output 24 V DC/50mA max., ON voltage 1.5 V or lower
- ◆ **Output update cycle** 0.1 seconds (100 msec)
- ◆ **Setting/selection** Individual setting (individual output), selectable
Details are the same as those for event outputs.
(However, LOGIC can be assigned to only DO1 to DO5. Direct can be assigned to only DO6 to DO9 with communication option. Posi.H, Posi.L, or POT.ER can be set when the controller is used with a feedback potentiometer.)
Details of setting range, hysteresis, action delay time and standby action are the same as those for event outputs.
- ◆ **Output characteristics switching** Normal open and normal close selectable
- ◆ **Isolation** Insulated between DO and various I/O, or DO and the system
Not insulated between DOs

20-7 External Control Input (DI)

- ◆ **Number of inputs** 10 points in total: standard 4 and 6 optional
 - DI1 to DI4 4 points
 - DI5 to DI10 6 points (optional)
- ◆ **Input rating** Non-voltage contact or open collector
 - Input specifications
Photocoupler input
5 V DC, 2.5mA max. voltage application per 1 input
 - Input holding time
0.1 seconds (100 msec)
- ◆ **Setting/selection** Individual setting (individual input), selectable
 - Input types
 - 1) None No action (no assignment)
 - 2) MAN Switching of control output between auto/manual (when ON: manual)
 - 3) REM Switching of REM SV/LOCAL SV setting (when ON: REM SV setting)
 - 4) AT Switching of AT execution/stop (at ON "edge": AT execution)
 - 5) STBY Switching of control execution/standby (when ON: standby)
 - 6) ACT Switching of direct/reverse action (when ON: direct action)
 - 7) Pause Switching of pause/resume of ramp control (when ON: ramp pause)
 - 8) LOGIC Logic operation (when ON: execution of logic operation and output to EV or DO)
 - 9) Preset 1 to 3
Preset No. switching by DI2 to DI4
 - 10) EXT_SV Multi-SV switching by DI7 to DI10 (only when DI option is selected)
- ◆ **Isolation** Insulated between DI and various I/O, or DI and the system
Not insulated between DIs.

20-8 Logic Operation Functions

- ◆ **Number of logic operation outputs**
 Assignable to 8 points in total: EV1 to EV3 3 points, DO1 to DO5 5 points
 DO4 and DO5 are exclusively for timer and counter operation.
- ◆ **Number of logic operation inputs**
 10 external control input points, DI1 to DI10, can be assigned individually to source 1 and source 2
- ◆ **Input logic conversion** Input logic conversion possible individually on source 1 and source2 (EV1 to EV3, DO1 to DO3 output)
 - 1) BUF By external control input logic
 - 2) INV Inversion of external control input logic
 - 3) FF Flip-flop logic operation of external control input
- ◆ **Logic operation (1)** Logic operation output by source 1 and source 2 (EV1 to EV3, DO1 to DO3 output)
 - 1) AND Output by logical product
 - 2) OR Output by logical sum
 - 3) XOR Output by exclusive OR
- ◆ **Logic operation (2)** Logic operation output by cause 1 (DO4, DO5 output)
 - 1) Timer operation OFF, 1 to 5000 seconds
 - 2) Counter operation OFF, 1 to 5000 counts

20-9 Analog Output (option)

- ◆ **Number of outputs** Maximum 2, Ao1, Ao2 individual setting, individual output
 Only Ao1 when sensor power supply (optional) is selected
- ◆ **Output types (assignments)**
 Selectable from 5 types
 - 1) PV Measured value (measured value in execution)
 - 2) SV Set value (set value in execution)
 - 3) DEV Deviation value (measured value in execution - set value in execution)
 - 4) OUT1 Control Output 1
 - 5) Posi Position value
- ◆ **Output rating** Individual selection (individual output)
 0 to 10 mV DC/output resistance 10Ω
 0 to 10 V DC/load current 2 mA max.
 4 to 20mA DC/load resistance 300Ω max.
- ◆ **Output accuracy** ±0.1% FS (of indicated value)
- ◆ **Output resolution** Approx. 1/14000
- ◆ **Output update cycle** 0.1 second (100 msec)
- ◆ **Output scaling** PV, SV within measuring range
 DEV within -100.0 to 100.0%;
 OUT1 within 0.0 to 100.0%; reverse scaling possible
 Posi within 0 to 100%
- ◆ **Isolation** Insulated between analog outputs and various I/O, or analog outputs and the system
 Not insulated between analog outputs (Ao1 and Ao2)

20-10 Sensor Power Supply (option)

- ◆ **Number of outputs** 1
Output from Analog Output 2 (Ao2) terminal
- ◆ **Output rating** 24V DC/25 mA max.
When the sensor power supply is selected, Analog Output 2 (Ao2) is unusable.
- ◆ **Isolation** Sensor power supply insulated from various I/O and system, analog output 1 and system

20-11 Communication (option)

- ◆ **Communication type**
RS-232C, RS-485
- ◆ **Communication system**
RS-232C 3-line half-duplex system
RS-485 2-line half-duplex multidrop (bus) system
- ◆ **Communication distance**
RS-232C 15 m max.
RS-485 500 m max. (depending on connection conditions)
- ◆ **Number of connectable devices**
RS-232C 1
RS-485 32 (differs depending on connection conditions including the host)
- ◆ **Synchronization system**
Start-stop synchronization
- ◆ **Communication speed**
2400, 4800, 9600, 19200 bps
- ◆ **Communication (device) address**
1 to 98
- ◆ **Communication delay time**
1 to 50 msec
- ◆ **Communication memory mode**
EEP, RAM, r_E
- ◆ **Communication protocol (1)** SHIMADEN protocol
Data length 7-bit, 8-bit
Parity EVEN, ODD, NONE
Stop bit 1-bit, 2-bit
Control code STX_ETX_CR, STX_ETX_CRLF, @_: _CR
Checksum (BCC) ADD, ADD_two's cmp, XOR, None
Communication code ASCII
- ◆ **Communication protocol (2)** MODBUS ASCII mode
Data length 7-bit (fixed)
Parity EVEN, ODD, NONE
Stop bit 1-bit, 2-bit
Control code _CRLF
Error check LRC check
Function code 03H and 06H (Hex) supported
1) 03H Read data
2) 06H Write data
- ◆ **Communication protocol (3)** MODBUS RTU mode
Data length 8-bit (fixed)
Parity EVEN, ODD, NONE
Stop bit 1-bit, 2-bit
Control code None
Error check CRC 16
Function code 03H and 06H (Hex) supported for
1) 03H Read data
2) 06H Write data

20-12 Infrared Communication

- ◆ **Communication system** Direct communication is possible with a PC through the infrared communication adapter (sold separately)
- ◆ **Number of connectable devices**
1
- ◆ **Infrared communication specification**
 - Synchronization system Start-stop synchronization
 - Communication speed 9600 bps
 - Data format 7E1 (7-bit, even parity, 1 stop bit)
 - Control code STX_ETX_CR
 - Checksum (BCC) ADD
 - Communication code ASCII
- ◆ **Communication protocol** Shimaden standard (extended) protocol

20-13 General Specifications

- ◆ **Data storage** Non-volatile memory (EEPROM)
- ◆ **Operating environment conditions**
 - Temperature -10 to 50°C
 - Humidity 90% RH max. (no dew condensation)
 - Elevation 2000 m above sea level or lower
 - Category II
 - Pollution class 2
- ◆ **Storage temperature** -20 to 65°C
- ◆ **Power voltage** 100 to 240 V AC $\pm 10\%$ 50/60 Hz
- ◆ **Power consumption** Max. 22 VA
- ◆ **Input noise removal ratio**
 - Normal mode 40 dB min. (50/60 Hz)
 - Common mode 120 dB min. (50/60 Hz)
- ◆ **Applicable standards**
 - Safety IEC61010-1 and EN61010-1
IEC61010-2-030 and EN61010-2-030
 - EMC EN61326-1
- ◆ **Insulation resistance**
 - Across I/O terminals and power terminal : 500 V DC 20M Ω min.
 - Across power terminals and ground terminal : 500 V DC 20M Ω min.
- ◆ **Dielectric strength**
 - Across I/O terminals and power terminal : 3000 V AC for 1 minute
 - Across power terminals and ground terminal : 1500 V AC for 1 minute
- ◆ **Protective structure** Front operating panel only is dust-proof and drip-proof.
(equivalent to IP66, NEMA4X)
- ◆ **Case material** PC resin molding (equivalent to UL94V-1)
- ◆ **External dimensions (H x W x D)**
 - 96 x 96 x 111 mm (panel depth:100 mm)
 - Panel depth is 112 mm when terminal cover is installed.
- ◆ **Mounting** Imbedded in panel (using mounting fixtures)
- ◆ **Thickness of usable panel** 1.0 to 8.0 mm
- ◆ **Size of panel cutout** 92 (H) x 92 (W) mm
- ◆ **Weight** 600 g max.

This page left intentionally blank

产品中有毒有害物质或元素的名称及含量

部件名称	有毒有害物质或元素					
	铅 (Pb)	汞 (Hg)	镉 (Cd)	六价铬 (Cr (VI))	多溴联苯 (PBB)	多溴二苯醚 (PBDE)
印制电路板	×	○	○	○	○	○
电子元器件	×	○	○	○	○	○
接线端子	○	○	○	○	○	○
外壳	○	○	○	○	○	○

○：表示该有毒有害物质在该部件所有均质材料中的含量均在SJ/T 11363-2006 标准规定的限量要求以下。
 ×：表示该有毒有害物质至少在该部件的某一均质材料中的含量超出SJ/T 11363-2006 标准规定的限量要求。

The contents of this Instruction Manual are subject to change without notice.

Temperature and Humidity Control Specialists

SHIMADEN CO., LTD.

<http://www.shimaden.co.jp/>

Head Office: 2-30-10 Kitamachi, Nerima-ku, Tokyo 179-0081 Japan
 Phone: +81-3-3931-7891 Fax: +81-3-3931-3089 E-mail:exp-dept@shimaden.co.jp

PRINTED IN JAPAN