

■ Preface

Thank you for purchasing our product. Before you start to operate the product, please read the following precautions at first, and use the product safely and carefully.

This Instruction Manual aims to summarize the Instruction Manual (Detailed version). For detailed contents, please refer to the product's original instruction manual (Detailed version) which can be downloaded for free from our website <http://www.shimaden.co.jp>.

Documents/Application software available for download are as follows.

- *FP23 series digital controller instruction manual (Detailed version) 1-input
- *FP23 series digital controller Communication interface (RS-232C/RS-485) instruction manual (Detailed version)
- *Parameter setup tool "Parameter Assistant"
- *USB setup software "USB SHIMADEN"

■ Operating environment

OS: Windows 7, Windows 10 (only 32-bit OS is supported)

Recommended CPU: Intel Celeron 700 MHz and above

Microsoft Windows, Windows 7 and Windows 10 are registered trademarks of Microsoft Corporation in the United States and other countries.

■ Checking accessories

Make sure that your product package has all of the following items

■ Standard accessories

- (1) Instruction Manual (A3 size paper ×4)
- (2) Mounting fixture (w/ 2 screws)
- (3) Terminal cover
- (4) Unit decal

■ Optional accessories

- (1) Current transformer (CT) for heater break alarm (when the heater break alarm option is selected)
- (2) Terminal resistor (when the RS-485 communication option is selected)

■ Contents

■ Safety Precautions	1
■ Precautions for Installation Site	1
■ Precautions for Wiring	1
■ External Dimensions	2
■ Panel Cutout Dimensions	2
■ Mounting.....	2
■ Rear Terminal Arrangement Diagram	2
■ Wiring Example of Open Collector Output.....	2
■ Names and Functions of Parts on Front Panel.....	3
■ Error Messages	3
■ LCD Flow Chart.....	4
■ Frequently-used Keys for LCD	4

■ Safety Precautions



Warning

The FP23 Series Digital Controller is control instruments designed for industrial use to control temperature, humidity and other physical quantities in general industrial facilities. It must not be used in any way that may adversely affect the safety, health or working conditions of those who come into contact with the effects of its use. When used, adequate and effective safety countermeasures must be provided at all times by the user. No warranty, express or implied, is valid when this device is used without the proper safety countermeasures.

- Before you start to use this device, install it in a control panel or the like and avoid touching the terminals.
- Do not open this device's case, and touch the boards or inside of the case with your hands or a conductor. The user should never repair or modify this device. Doing so might cause an accident that may result in death or serious bodily injury from electric shock.



Caution

To avoid damage to connected peripheral devices, facilities or the product itself due to malfunction of this device, safety countermeasures such as proper installation of the fuse or installation of overheating protection must be taken before use. No warranty, express or implied, is valid in the case of use resulting in an accident without having taken the proper safety countermeasures.

- The warning mark on the plate affixed on the casing of this device warns you not to touch charged parts while this device is powered ON. Doing so might cause an electric shock.
- A means for turning the power OFF such as switch or a breaker must be installed on the external power circuit connected to the power terminal on this device. Fasten the switch or breaker at a position where it can be easily operated by the operator, and indicate that it is a means for powering this device OFF.
- This device does not have a built-in fuse. Install a fuse that conforms to the following rating in the power circuit connected to the power terminal.

Fuse rating/characteristics: 250 VAC 1.0A/medium lagged or lagged type

- When wiring this device, tighten the terminal connections firmly.
- Use the device with the power voltage and frequency within their rated ranges.
- Do not apply a voltage or current outside of the input rating to the input terminal. Doing so might shorten the service life of this device or cause it to malfunction.
- The voltage and current of the load connected to the output terminal should be within the rated range. Exceeding this range may cause the temperature to rise which might shorten the service life of this device or cause it to malfunction.
- This device is provided with ventilation holes for heat to escape. Prevent metal objects or other foreign matter from entering these ventilation holes as this may cause this device to malfunction. Do not block these ventilation holes or allow dirt and dust to stick to these holes. Temperature buildup or insulation failure might shorten the service life of this device or cause it to malfunction.
- Repeated tolerance tests on voltage, noise, surge, etc. may cause this device to deteriorate.
- Never remodel this device or use it a prohibited manner.
- To ensure safe and proper use of this device, and to maintain its reliability, observe the precautions described in this manual.
- Do not operate the keys on the front panel of this device with a hard or sharp-tipped object. Be sure to operate the keys with your fingertips.
- When cleaning this device, do not use paint thinner or other solvents. Wipe gently with a soft, dry cloth.
- It takes 30 minutes to display the correct temperature after applying power to the digital controller. (Therefore, turn the power on more than 30 minutes prior to the operation.)

■ Precautions for Installation Site



Caution

Do not use this device in the following sites. Doing so might result in malfunction or damage to this device and in some cases cause fire and/or dangerous situations.

- Locations that are filled with or generate inflammable gas, corrosive gas, dirt and dust, smoke, etc.
- Locations that are subject to water droplets, direct sunlight or strong radiated heat from other equipment
- Locations where the ambient temperature falls below -10°C or rises above 50°C
- Locations where dew condensation forms and the humidity reaches 90% or more
- Near equipment that generates high-frequency noise
- Near heavy current circuits or locations likely to be subject to inductive interference
- Locations subject to strong vibration and impact
- Locations exceeding an elevation of 2000 m

■ Precautions for Wiring

Caution

- To prevent electric shock, always turn off and disconnect this device from the power supply before starting wiring.
- Do not touch wired terminals or charged parts with your hands while the power is supplied.

Pay attention to the following points when performing wiring:

- Check that the wiring is free from mistakes according to "■ Rear Terminal Arrangement Diagram."
- Use crimped terminals that accommodate an M3 screw and that have a width of 6.2 mm or less.
- For thermocouple input, use a compensation wire compatible with the type of thermocouple.
- For RTD input, the resistance of a single lead wire must be 10Ω or less and the three wires must have the same resistance.
- The input signal lead must not be passed along the same conduit or duct as that for high-voltage power lines.
- Shield wiring (single point grounding) is effective against static induction noise.
- Short interval twisted pair wiring is effective against electromagnetic induction noise.
- When wiring, use wire or cable (minimum 1 mm² cross-sectional area) of 600 V grade PVC insulated wire or equivalent wire having the same rating.
- For wiring the ground, ground the ground terminal with the earth resistance at less than 100Ω and with wire 2 mm² or thicker.
- Two earth terminals are provided, each connected internally. One is for the ground connection, and the other is for connecting the shield of the signal lead. Do not use the earth terminals for crossover wiring of the power system ground lead.
- If this device is considered as being susceptible to noise caused by the power supply, attach a noise filter to prevent abnormal functioning. Install a noise filter onto a grounded panel, and make the wire connecting the noise filter output and the power supply terminal on this controller as short as possible.

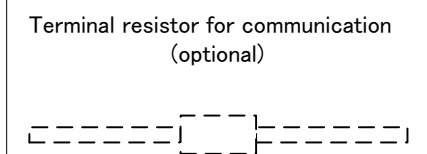

Names and Functions of Parts on Front Panel

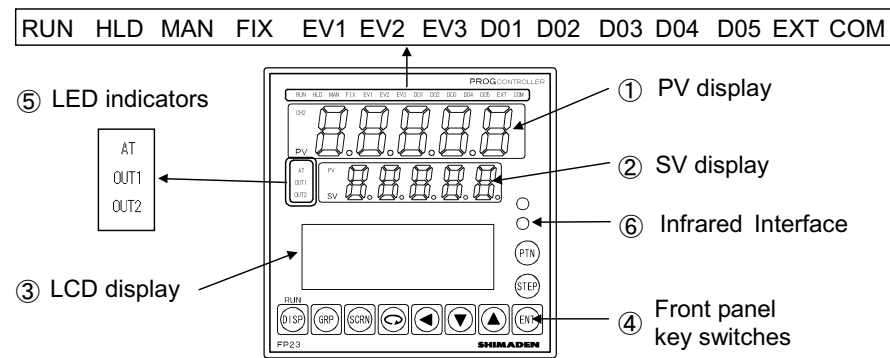

① PV display

Displays the measured value (PV).
 Displays an error message when an error (e.g. scale over) occurs.

② SV display

Displays the target set value (SV).

③ LCD display (21 characters x 4 lines, max.)

Pattern/step No. display

Displays the pattern/step No. in the Program mode.
 In the FIX mode, "F" is displayed at the PTN field and "-" is displayed at the STEP field.
 "-" at the STEP field goes out during control execution (RUN) in the FIX mode.

Output (OUT) display

The control output value is displayed by a numerical value and a bar graph as a percentage (%).

Program monitor display

Displays the program status monitor.

Remaining step time display

Displays the remaining step time during program operation.

Pattern graph display

Displays the pattern (step) graph during program operation.

Screen title display

Displays the screen group title in the respective screen group top screen.

Setup parameter display

Parameters can be selected and displayed by front key operation.

④ Front panel key switches

DISP	Displays the basic screen.
GRP	Changes the screen group. Or, returns to the screen group top screen.
SCRN	Switches the parameter display screen in a screen group.
	Selects the parameter to set up or change. The parameter to be changed is indicated by the cursor (▶).
	Moves the digit in set numerical values.
	Decrements parameters and numerical values during setup.
	Increments parameters and numerical values during setup.
ENT	Registers data or parameter numerical values.
STEP	At a reset, increments the start step No. in the basic screen. (ENT must be pressed to register.)
PTN	At a reset, increments the start pattern No. in the basic screen. (ENT must be pressed to register.)

The following key combination operations are available in screens from 0-1 to 0-6.

ENT + PTN	Hold (HLD) operation
ENT + STEP	Advance (ADV) operation

⑤ LED indicators

Status lamps

RUN	green	Lights during program execution. Blinks during program start delay time (PRG.Wait).
HLD	green	Lights when the program is paused in the Program mode. Blinks when the pause has caused by an input error in Program mode or in the Fix mode.
MAN	green	Blinks when control output is set to manual operation (MAN).
FIX	green	Lights in the FIX mode.
EV1	orange	Lights during EV1 action.
EV2	orange	Lights during EV2 action.
EV3	orange	Lights during EV3 action.
DO1	orange	Lights during DO1 action.
DO2	orange	Lights during DO2 action.
DO3	orange	Lights during DO3 action.
DO4	orange	Lights during DO4 action.
DO5	orange	Lights during DO5 action.
EXT	green	Lights when start pattern No. selection (PTN2bit, PTN3bit, PTN4bit, PTN5bit) are set to DI5 to DI8.
COM	green	Lights when communication (COM) mode is selected.
AT	green	Blinks during execution of auto tuning, and lights during auto tuning standby.

OUT1	green	When control output is current or voltage output, the brightness of this lamp changes according to fluctuation of Control Output 1, and during contact or SSR drive voltage output, this lamp lights when Control Output 1 is ON and goes Out when Control Output 1 is OFF.
OUT2	green	When control output is current or voltage output, the brightness of this lamp changes according to fluctuation of Control Output 2, and during contact or SSR drive voltage output, this lamp lights when Control Output 2 is ON and goes Out when Control Output 2 is OFF.

■ Error Messages

Code	Cause	
E-roñ	ROM error	The error codes on the left are displayed on the PV display. These indicate that all outputs turn OFF or become 0%. If any of the messages are displayed, repair or replacement is required. Immediately turn the power OFF, and contact your dealer.
E-rAñ	RAM error	
E-EEP	EEPROM error	
E-Ad1	Input 1 A/D error	
E-SPc	Hardware error	
Sc.LL	The PV value exceeded the measuring range lower limit (-10%FS).	When a PV input-related abnormality is detected during execution of control on this device, the error codes on the left are displayed on the PV display. Check input or the heater lead. If the input or the heater lead is not in error and there is another probable cause, contact your dealer.
Sc.HH	The PV value exceeded the measuring range higher limit (+110%FS), RTD-A burnout, or thermocouple burnout.	
b - - -	One or two RTD-B burnout, or all leads of the RTDs burnout. Action of this device in this case is PV moving excessively towards the higher limit.	
CJ.LL	Reference junction compensation (-20°C) is at the lower limit. (thermocouple input)	When a heater current abnormality is detected during execution of control on this device, this error code is displayed on the LCD.
CJ.HH	Reference junction compensation (+80°C) is at the higher limit. (thermocouple input)	
Hb.HH	The heater current exceeds 55.0A.	

LCD Flow Chart

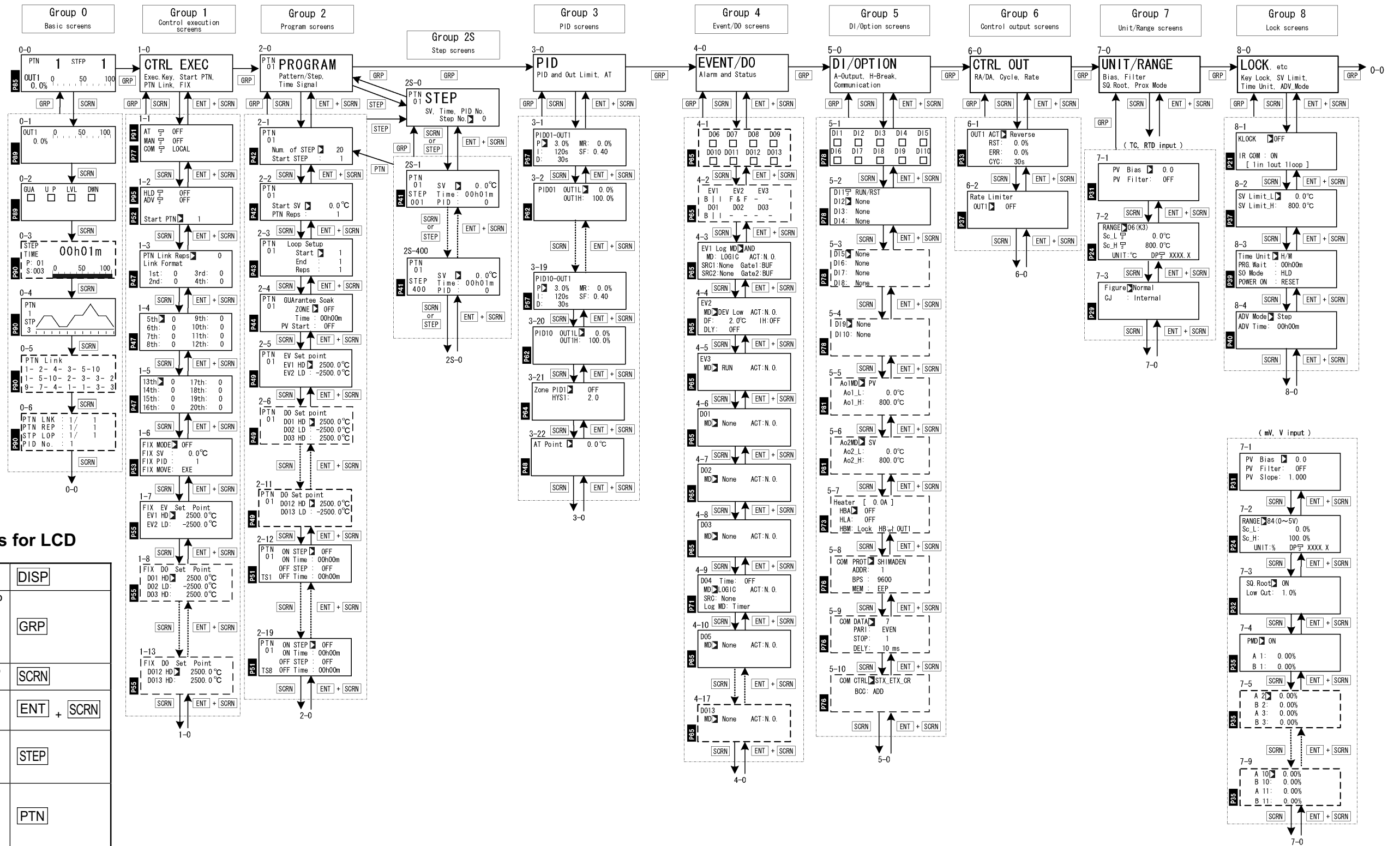

Frequently-used Keys for LCD

Move to 0-0 Screen (Example : 2-5→0-0)	DISP
Move from a 0 screen of a group to another (Example : 0-0→1-0→2-0)	GRP
Move to the group's 0 screen (Example : 2-4→2-0)	PTN
Move to the next screen in a group (Example : 2-0→2-1→2-2)	SCRN
Move to the previous screen in a group (Example : 2-2→2-1→2-0)	ENT + SCRN
Modify the Step No. at 0-0 Screen Move to the step screens from 2-0 Screen (Example : 2-0→2S-0)	STEP
Modify the Pattern No. at 0-0 Screen Move to Program screens from Step screens (Example : 2S-1→2-1)	PTN
Move to the next parameter in a screen (Example : AT→MAN at 1-1)	↻
Modify a value for a parameter (Example : P at 3-1)	▼ or ▲
Move from digit to digit for a value	◀
Register a modified value	ENT

Standard screen Screens that are always displayed

Non-standard screen Screens that are displayed depending on options/setup values.

Please see pages xii and xiii in the FP23 series digital controller instruction manual (Detailed version) 1-input.