

°C

%RH

SHIMADEN

Series PAC27

SINGLE PHASE POWER REGULATOR



CE approved

BASIC FEATURES

- Phase Angle or Cycle Operation Zero Voltage Switching**
- Current Capacity: 20, 30, 45, 60, 80, 100A**
- Power Supply: 100~120/200~240V AC**
- On the condition that the product is used with a noise filter as specified by SHIMADEN, the CE safety standard (EMC Directive) shall be satisfied.**
 - *This applies to instance where the apparatus employs the phase angle control system or when the cycle operation zero-voltage switching system is utilized.**
- As we attach importance to safety aspects, the instrument has a number of alarm circuits including a built-in voltage feedback circuit as a standard function.**
- If you select the current or the voltage control system, or the voltage square switching control system from the optional functions, control of special types of heaters and transformer loading is possible.**

- A variety of functions that can deal with an extended range of applications:
The apparatus is widely used for the thermoelectric control of airconditioners, electric furnaces, driers, biotechnological, food processing, chemical, semiconductor manufacturing, plastic, and other equipment. The PAC27 series apparatuses are smaller in size. They are 30% or so smaller in capacity as compared to their predecessors of the PAC26 series, thus enhancing safety-related functions.
- Increased and/or improved standard functions equipped in the apparatus:
You can select either of two control system; the phase angle control or the cycle operation zero-voltage switching control.

• Control System and Output Waveform

System Output	Phase control system (PAC27P)	Cycle operation zero voltage switching control system (PAC27C)
0%		
30%		
50%		
70%		
100%		
Noise generation	Heavy	Light
Output	Continuous	Intermittent
Output stability	Output fluctuation is within 2% against $\pm 10\%$ power fluctuation (constant voltage characteristics)	Output follows power fluctuation.

- The phase angle control system of the PAC27 series has the voltage feedback function as standard equipment.
Internal power adjustment and soft start time adjustment are equipped as standard functions.

• Power Adjustment

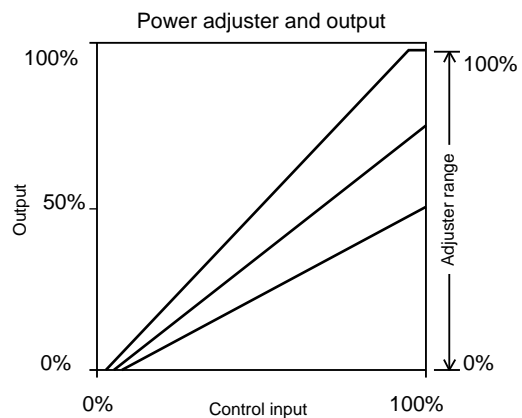
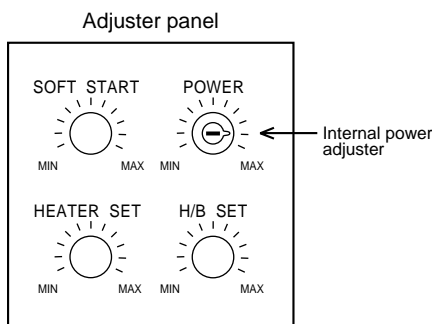

• Soft Start Time Adjustment

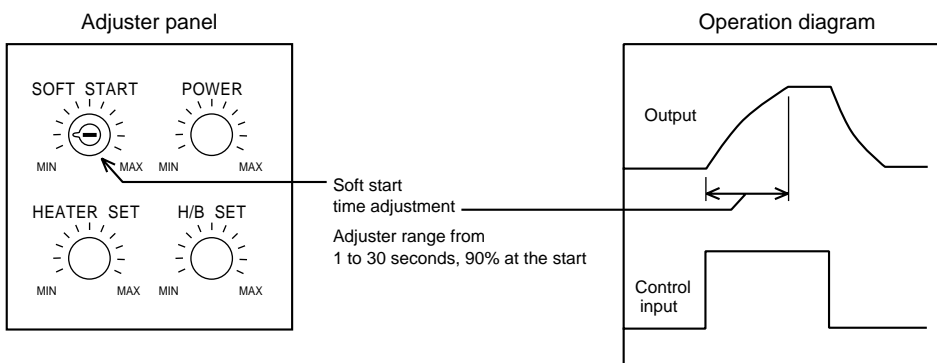

- As the PAC27 series has a built-in overcurrent protection circuit, an alarm action signal is output when the overcurrent gate breaking circuit is placed in operation, upon malfunction of the rapid fuse, when SCR is overheated, or upon detection of SCR shorting.

The availability of various optional functions allows for a wide range of uses.

One of the current, power, or voltage square feedback systems being selectable, that control which is most appropriate for the characteristics of your heater can be carried out.

• **Special Heater and Feedback Control (PAC27P)**

Type of heater	Feedback control system Additional function
Supercantal	Constant voltage control + current limiting, Constant power control + current control, Constant current control
Pure metals (platinum, molybdenum, tungsten, etc.)	Constant voltage control + current limiting, Constant power control + current control, Constant current control
Carbon	Constant voltage control (+ current limiting), Constant power control
Salt bath	Constant voltage control (+ current limiting), Constant current control
SiC (silicon carbide)	Constant voltage control (+ current limiting), Constant power control, Constant current control

- **Current Capacity and Calorific Value**

When current flows in the thyristors, voltage (0.9-1.3 V) is generated across the terminals. The product (W) of this voltage across the terminals and the current is Joule heat, which raises the temperature of the thyristor elements.

Full consideration needs to be given to radiation of heat and ventilation.

• **PAC 27 Internal Calorific Value**

Current Capacity	20A	30A	45A	60A	80A	100A
Calorific value without fuse	23W	35W	54W	59W	79W	103W
Calorific value with fuse	25W	37W	58W	63W	85W	110W

- **Ambient Temperature and Load Current**

The current rated for the PAC27 is at 50°C of ambient temperature. In case ambient temperature exceeds 50°C, the instrument should be used with load current as illustrated below.

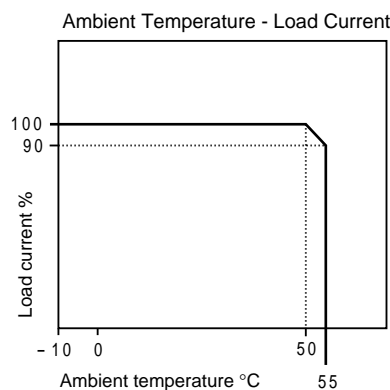

- Since the thyristors, particularly in phase control, use a cut-out portion of the sine waveform of power supply, distortion in power waveforms is caused if the power has a high impedance. In addition, switching the power supply every half cycle causes a switching noise. Such power distortion and noise may affect other machines and devices in some cases.
By utilizing the zero voltage switching system, power is switched nearly at its zero cross point. This results in much less noise than that caused by phase control.
Because a large electric current is switched, however, a certain level of noise generation is inevitable. It is recommended that you use a noise filter.
Additionally, in case power impedance is high, the power source may be shaken (flicker) synchronously with ON/OFF of the thyristor.

- **Noise Filter**
Frequency components of noise generated by the thyristors are distributed in a few megahertz or lower areas. Universal noise filters available on the market do not have sufficient effect to reduce such noise. It is possible to decrease such noise when the following noise filter as designated herein is used.
The filter is specified for use in our thyristor power regulators.

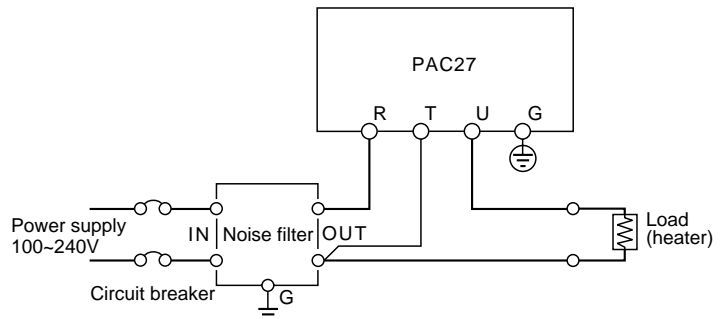

EXTERNAL DIMENSIONS & WEIGHT FOR NOISE FILTER OPTION

- **Noise Filter HF2000A-XB Series**

Item	Current Amp	Dimension							Weight Kg
		Unit: mm							
		A	B	C	D	E	F	G	
HF2030A-XB	30 A	248	240	220	200	90	70	80	1.8
HF2050A-XB	50 A	268	250	235	220	90	70	80	2.5
HF2060A-XB	60 A	268	250	235	220	90	70	80	2.5
HF2080A-XB	80 A	304	280	265	250	130	110	95	4.5
HF2100A-XB	100 A	304	280	265	250	130	110	95	5.0

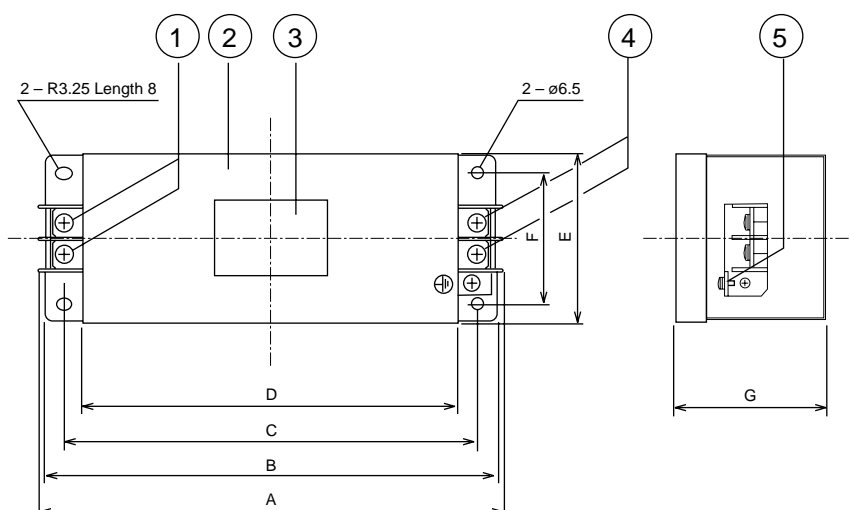

NO	NAME
1	Input terminal
2	Metal Case
3	Name Plate
4	Output terminal
5	Ground terminal



⚠ CAUTION

When the product is used with a noise filter and wired as specified by the instruction manual, the product meets the requirement of EC directive.

1. For dealing with EMC command

- ① Use in combination with a noise filter designated by us. Install the noise filter on the same metal plate as the PAC27. Do not forget to properly ground it.
- ② The length of wiring between the noise filter and the PAC27 should be 0.5m or less.

2. For dealing with low-voltage command

- ① When power line is wired, as a precaution against accidental shorting, make sure to install one molded case circuit breaker for each PAC27.
- ② The current capacity of a molded case circuit breaker should be less than 1.3 times as high as that of the PAC27.

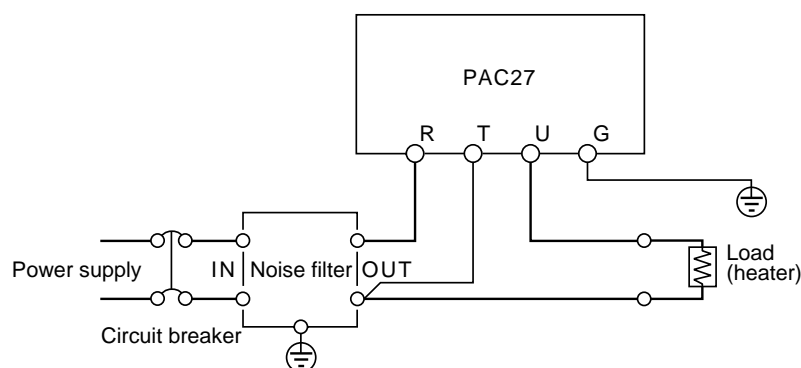

Common Specifications

- Control element configuration:
Thyristor (SCR) x 2 Anti-parallel connection
- Power supply:
100~110V, 110~120V, 200~220V, 220~240V AC
±10% 50/60 Hz
- Rated frequency:
Common to 50/60Hz
- Current capacity:
20, 30, 45, 60, 80, 100A
- Control input signal:
Current: 4~20 mA DC / Receiving impedance: 100Ω
Voltage: 1~5 V DC / Input impedance: 200kΩ minimum
Others: Voltage, current signal
Contact: No-voltage contact signal
- Power Adjuster:
Voltage and current input types - Internal power adjuster is equipped on standard basis.
External power adjuster is mountable at option.
- Element protection system:
Electronic overcurrent gate breaking circuit (when in action, alarm is output.)
Rapid fuse (option) (Upon fuse breaking, alarm is output.)
- Alarm action:
When overcurrent gate breaking circuit is in action, when rapid fuse breaks, when thyristors are overheated, when shorting of thyristors is detected, when current flows across alarm output terminals (AL1 and AL2) (contact 240V AC, 1A)
- Additional functions (Common options)
Rapid fuse: with alarm output
External power Adjustment functions: External power
Manual power
High/low power
High power
Low power
External power + manual power
Heater break alarm: To be set at 0 to 100% of rated current
- Operating environment:
Ambient temperature range: between -10 and 50°C
Ambient humidity range: 90% RH maximum with no dew condensation
Storage temperature: between -20 and 65°C
- Applicable standards:
Safety IEC 1010-1
EMC EMI (emission) EN55011 class A, Group 1
EMS (immunity) EN50082-2 on condition that designated noise filter is used.
- Insulation resistance/dielectric strength
Insulation resistance: 500VDC 20MΩ minimum between power supply terminal and chassis
Dielectric strength: 2000VAC/min. between power supply terminal and chassis
2300VAC/min. between power supply terminal and control input

Individual Specifications

- PAC27P
Control System: Phase control
Soft start time: Adjustable possible between 1 and 30 seconds
Output voltage control range: 0 to 97% of input voltage
Degree of output stability: Output fluctuation ±2% maximum as against input fluctuation ±10%
Output voltage characteristics: Linear output by voltage feedback (various characteristics are selectable as designated)
Applicable load: All heaters (additional functions to be selected suitably for characteristics)
Inductive load and transformer primary control
Power supply display: Green LED lamp lights.
- Additional functions (options)
Power adjuster functions:
See appropriate item in common specifications.
Constant current control (current FB):
Output current in proportion to control input signal
Constant power control (power FB):
Output power in proportion to control input signal
Power linear control (voltage² FB):
Control and the square of output voltage are proportional to each other.
Current limiting function:
Current is limited to 50 to 100% of the rating.
- PAC27C
Control system: Cycle operation type zero voltage switching control system with soft start action (time variable function)
Output control range: 0 to 95% of load power
Output indicator: Green LED lamp lights.
Applicable load: Constant resistance load (Transformer primary control not allowed)
- Additional function (option)
Manipulated variable indicator:
Ratings
Current sensitivity: 1 mA
Scale: 0 to 100% (0~1mA DC)



External dimensions

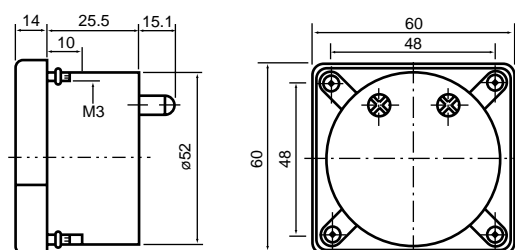

Unit : mm

■ Rapid fuse (option)

– Type of fuse –

Rated current	Type of fuse	Fuse rating
20A	25SHA30S	30A
30A	25SHA40S	40A
45A	25SHA60S	60A
60A	25SHA85S	85A
80A	25SH150S	150A
100A	25SH150S	150A

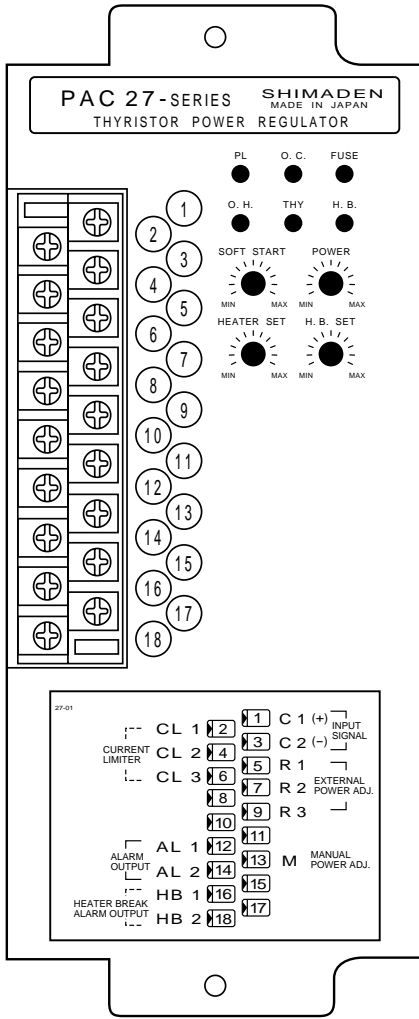

- Names of monitor lamps
- PL : Power display (phase control)/Output display (cycle operation)
- O.C. : Overcurrent protection action display
- FUSE : Rapid fuse fusing display (option)
- O.H. : Thyristor overheating alarm display
- THY : Thyristor short circuit display/open load display
- H.B. : Heater break alarm action display (option)

- Names of adjuster
- POWER : Power adjuster
- SOFT START : Soft start time adjuster
- HEATER SET : Heater setting device for heater break alarm (option)
- H.B. SET : Heater break alarm setting device (option)

- Terminal codes and description
- C1-C2 : Control input signal
- R1-R2-R3 : External power
- M : Manual operation power (voltage/current input)
- L2-L3 : Low power (contact input)
- CL1-CL2-CL3 : Current limit setting device (option for phase control)
- MO1-MO2 : Manipulated variable indicator (cycle operation)
- AL1-AL2 : Alarm output
- HB1-HB2 : Heater break alarm output (option)

□ Control Terminal Numbers and Marking

Terminal No.	Code	Terminal code	
		Voltage/current input	Contact input
Top terminals	1	C1 (+)	C1
	3	C2 (-)	C2
	5	R1	R1
	7	R2	R2
	9	R3	R3
	11	---	L2
	13	M	L3
15	---	---	
17	---	---	
Bottom terminals	2	Phase control	Cycle operation control
	4	CL1	MO1
	6	CL2	MO2
	8	---	---
	10	---	---
	12	AL1	AL1
	14	AL2	AL2
	16	HB1	HB1
18	HB2	HB2	

CIRCUIT BLOCK DIAGRAM

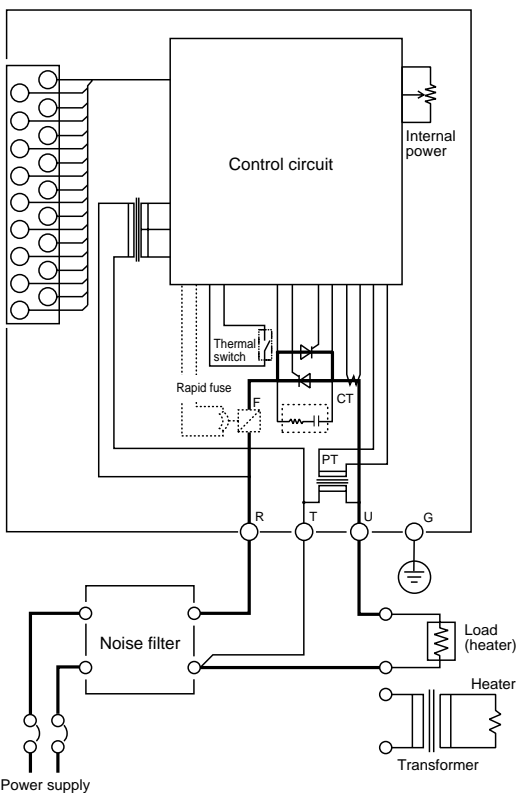

□ Terminal Marking

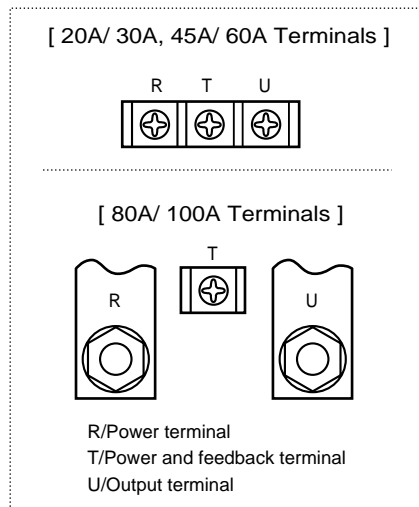

External power adjuster

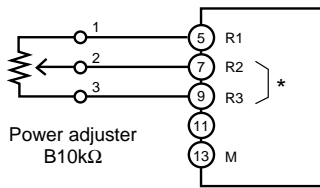

* When an external power adjuster is not used, the terminals 7 (R2) and 9 (R3) should be shorted.

Base (residual) power adjuster

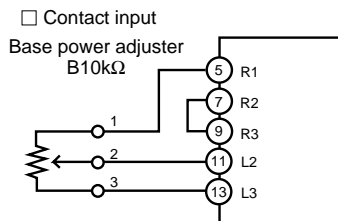

This is used to allow for output even when the control signal is at 0%. Adjusting range is 0~100%.

When automatic operation + manual power adjuster switch is used (voltage/current input type)

- External power + manual power adjuster
- Manual power adjuster

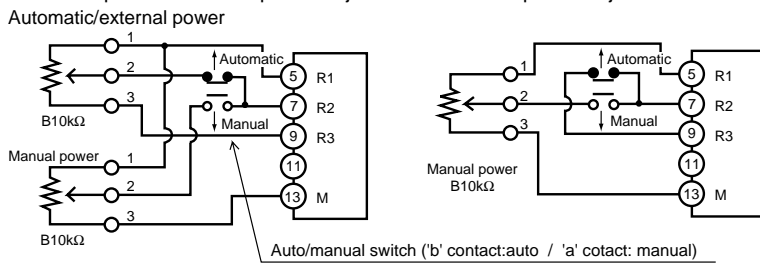

Provide an auto/manual switch contact externally as shown in the drawing. It is safe to use the 'b' contact for auto and the 'a' contact for manual.

Contact input High-low power adjuster

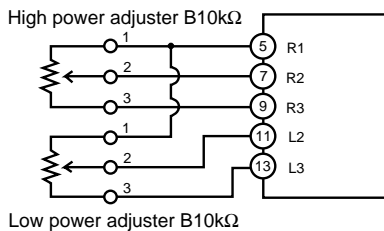

- High power: When current flows across C1-C2, output can be adjusted in a range from 0 to 100%.
- Low power: When C1-C2 are open, residual output is regulated. Residual output = (high power) x (low power)

Example: When high power = 70% and low power = 40%, residual output is 70% x 40% = 28%

External power adjuster



• External dimensions and mounting sizes

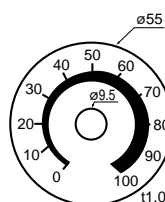
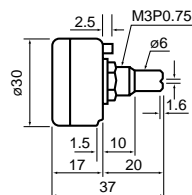

Panel cutout

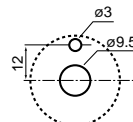

- Name and scale / 0 to 100 %
- External power adjuster / same as above
- Manual power adjuster / same as above
- Base power adjuster / same as above
- High/low power adjuster / same as above
- Current limit setting device / 50 to 100%

Phase Angle Control (PAC27P)

ITEMS	CODE		SPECIFICATIONS
SERIES	PAC27P		Phase Angle Control Single Phase Power Regulator
CONTROL INPUT	2		Contact
	3		1~5V DC Input Resistance: 200kΩ min.
	4		4~20mA DC Receiving Resistance: 100Ω
	6		0~10V DC Input Resistance: 200kΩ min.
	9		Others (Please consult before ordering)
POWER SUPPLY	13-		100~110V AC±10%, 50 / 60Hz
	14-		110~120V AC±10%, 50 / 60Hz
	15-		200~220V AC±10%, 50 / 60Hz
	16-		220~240V AC±10%, 50 / 60Hz
CURRENT CAPACITY	020		20A
	030		30A
	045		45A
	060		60A
	080		80A
	100		100A
FEEDBACK FUNCTION	0		Constant Voltage Control (standard feature)
	1		Constant Current Control
	2		Constant Power Control
	3		Power linear Control
CURRENT LIMIT FUNCTION	0		None
	1		With
EXTERNAL POWER ADJUSTER	CONTACT INPUT	N	None (Internal installation as standard)
		P	External power adjuster
		B	Base (low) power adjuster
		H	High/Low power adjuster
	CURRENT/VOLTAGE INPUT	P	External power adjuster
		M	Manual power adjuster
		W	External power + Manual power
HEATER BREAK ALARM	0		Without
	1		With
RAPID FUSE	0		Without
	1		With
REMARK	0		Without
	9		With (Please consult before ordering.)

Noise Filter (Option)

Type	Current capacity
HF2030A-XB	30A
HF2050A-XB	50A
HF2060A-XB	60A
HF2080A-XB	80A
HF2100A-XB	100A

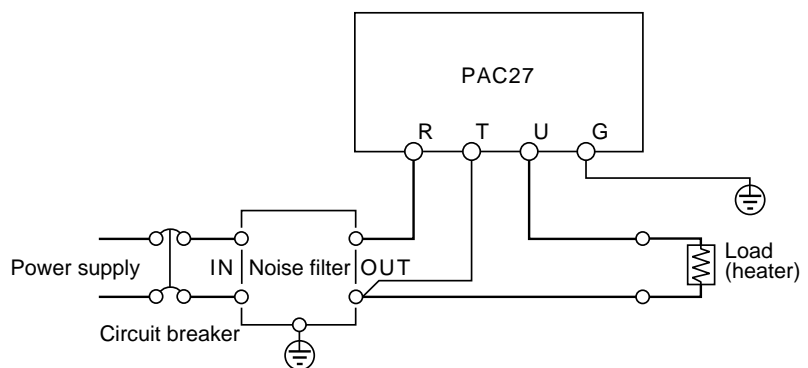

On the condition that the product is used with a noise filter as specified by SHIMADEN, the CE safety standard (EMC Directive) shall be satisfied.

Cycle Operation Zero-voltage Switching (PAC27C)

ITEMS	CODE		SPECIFICATIONS
SERIES	PAC27C		Zero Voltage Switching Single Phase Power Regulator
CONTROL INPUT	2		Contact
	3		1~5V DC Input Resistance: 200kΩ min.
	4		4~20mA DC Input Resistance: 100Ω
	6		0~10V DC Input Resistance: 200kΩ min.
	9		Others (Please consult before ordering)
POWER SUPPLY	13-		100~110V AC±10%, 50 / 60Hz
	14-		110~120V AC±10%, 50 / 60Hz
	15-		200~220V AC±10%, 50 / 60Hz
	16-		220~240V AC±10%, 50 / 60Hz
CURRENT CAPACITY	020		20A
	030		30A
	045		45A
	060		60A
	080		80A
	100		100A
EXTERNAL POWER ADJUSTER	CONTACT INPUT	N	None (Internal installation as standard)
		P	External power adjuster
		B	Base (low) power adjuster
		H	High/Low power adjuster
	CURRENT/VOLTAGE INPUT	P	External power adjuster
		M	Manual power adjuster
		W	External power + Manual power
HEATER BREAK ALARM	0		Without
	1		With
RAPID FUSE	0		Without
	1		With
OPERATING OUTPUT INDICATOR	0		Without
	1		With (0-1mA DC, 0-100%scale)
REMARK	0		Without
	9		With (Please consult before ordering.)

Noise Filter (Option)

Type	Current capacity
HF2030A-XB	30A
HF2050A-XB	50A
HF2060A-XB	60A
HF2080A-XB	80A
HF2100A-XB	100A

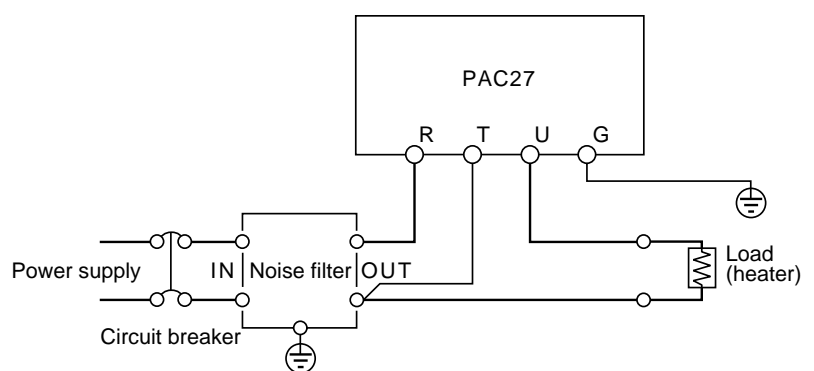

On the condition that the product is used with a noise filter as specified by SHIMADEN, the CE safety standard (EMC Directive) shall be satisfied.

Safety should be taken well into consideration in using this instrument by fixing it to a control panel, wall or rack so as to keep it from easy contact with persons.

It has to be installed vertically for heat radiation, leaving more than 100 mm spaces above and below it respectively.

If it is inevitable to install the instrument horizontally, it must be used with less than 70% of the rated current.

□ Mounting Sizes

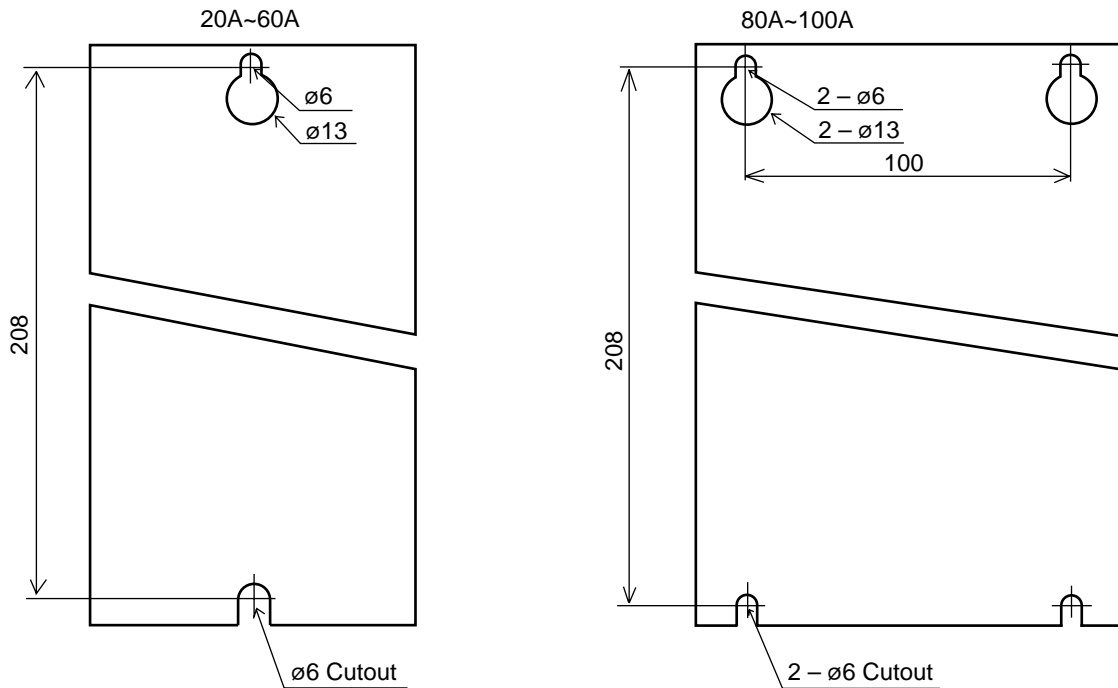

□ Intervals Required for Mounting

Open the cover when wiring is carried out for the instrument. Stick to the following interval sizes.

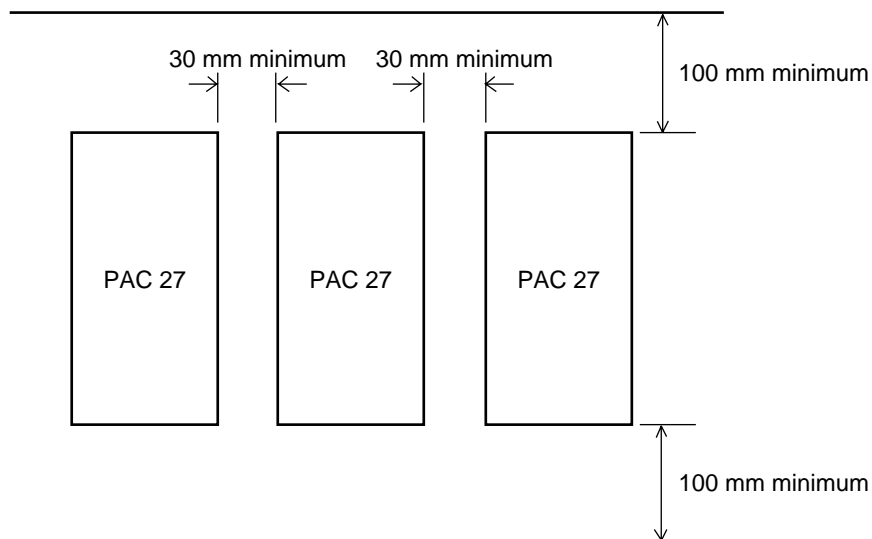

EXTERNAL DIMENSIONS & WEIGHT

Series **PAC27**

□ 20A / 30A, 45A / 60A

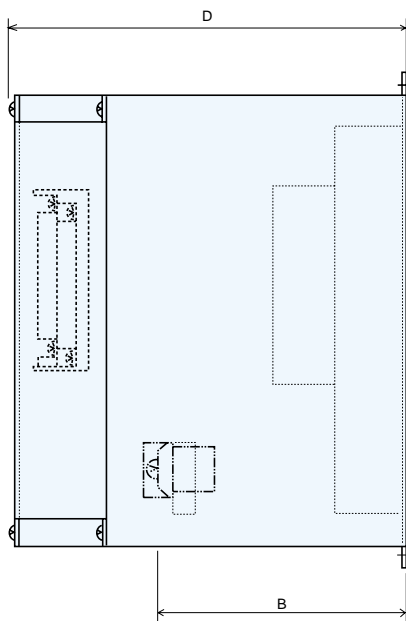
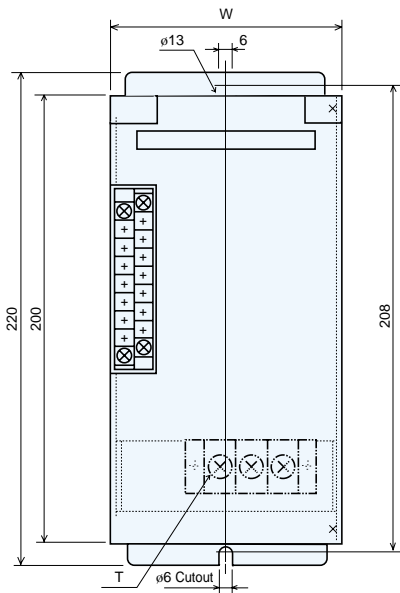

Weight
 20A, 30A : Approx. 2.2kg
 45A, 60A : Approx. 3.1kg

Current Code	20A/30A	45A/60A
W	81	102
D	160	176
B	90	108
T	M4	M5

Unit : mm

□ 80A / 100A

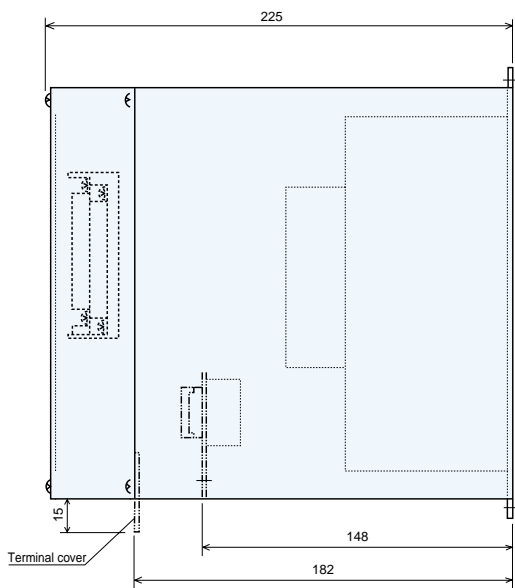
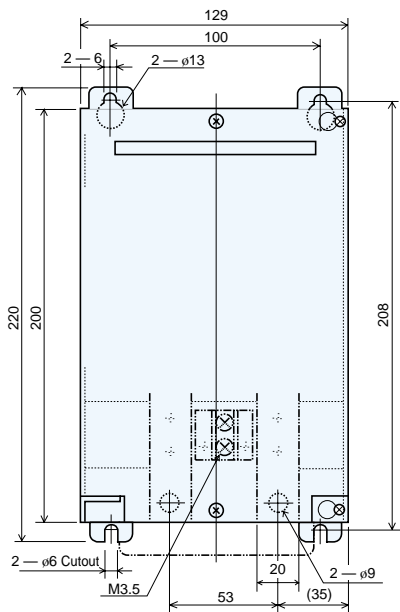

Weight
 80A, 100A : Approx. 4.4kg

Unit : mm

Warning

- The PAC27 series is designed for controlling the power of a heater or similar equipment used in a general industrial facilities. (It is not to be used for any purpose which regulates the prevention of serious effects on human life or safety.)

Caution

- If the possibility of loss or damage to your system or property as a result of failure of any part of the process exists, proper safety measures must be made before the instrument is put into use so as to prevent the occurrence of trouble.



ISO 9001

(The contents of this brochure are subject to change without notice.)

Temperature and Humidity Control Specialists
SHIMADEN CO., LTD.
 Head Office: 2-30-10 Kitamachi, Nerima-Ku, Tokyo 179-0081 Japan
 Phone: +81-3-3931-7891 Fax: +81-3-3931-3089
 E-MAIL: exp-dept@shimaden.co.jp URL: http://www.shimaden.co.jp