

°C

%RH

SHIMADEN

Series SD24 & KR17

## SHIMADEN DIGITAL INDICATOR



CE approved

### PRODUCT FEATURE

- High Accuracy  $\pm 0.1\%$  FS+1 digit**
- 1/1000 °C Resolution Indication Possible (Pt input 0.000 to 30.000 °C)**
- 3 Display Modes (Peak Hold, Bottom Hold, Display Hold)**
- External Control Input (2 points) as a Standard Feature**
- C contact (2 points) or a contact (4 points) can be selected for alarm output.**
- Analog Output Hold Function (Hold Display Value Output)**
- Communication Function RS-485/RS-232C**  
(Shimaden Standard Protocol/MODBUS)
- Linear Approximation Operation Function (Voltage/Current Input only)**
- Dust-proof and drip-proof structure: IP66 equivalent**

	SD20	SD24
<b>Number of digit</b>	4 digits	<b>5 digits</b>
<b>Accuracy</b>	0.25%	<b>0.1%</b>
<b>Input</b>	Specified by customer	<b>Universal</b>
<b>Display cycle range</b>	0.25 sec.	<b>0.1 sec.</b>
<b>RoHS compliance</b>	Non-compliant	<b>Compliant</b>
<b>Linear approximation function</b>	Without	<b>With</b>
<b>Analog output hold</b>	Without	<b>With</b>

Example of use

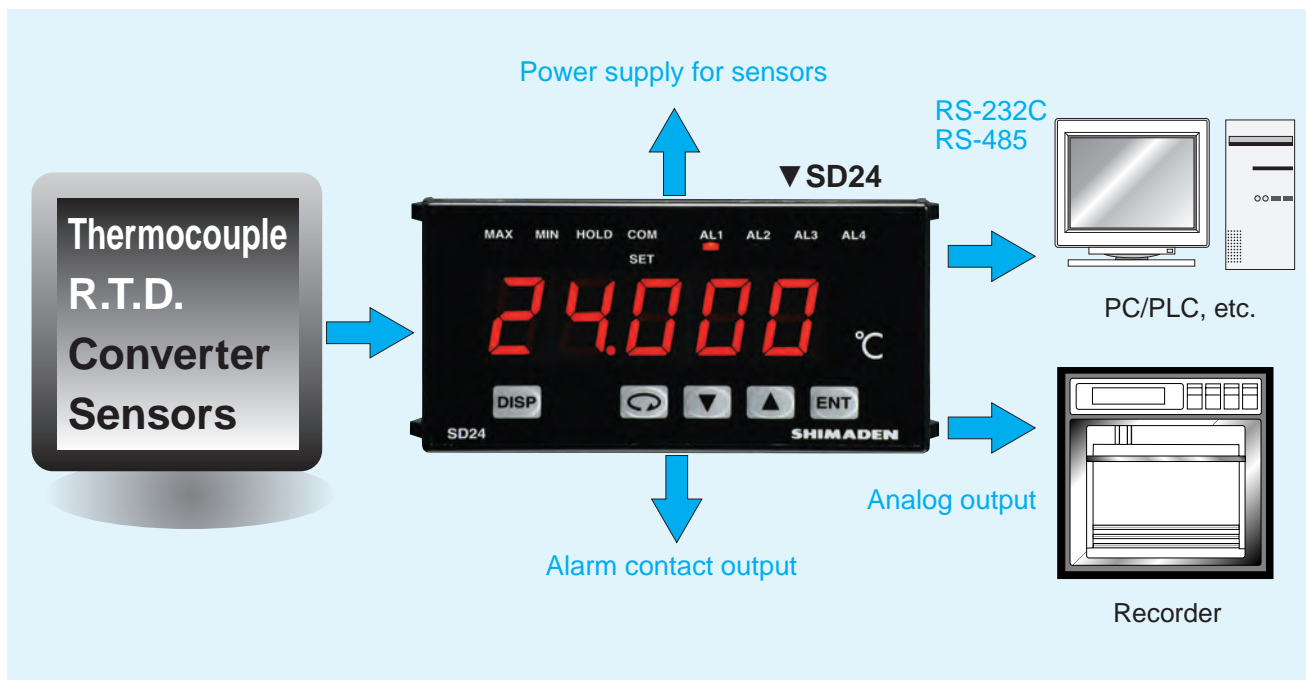

■ **Display**

- Display methods
  - Digital display : Measured value (PV) /7 segments red LED 5 digits Height of character: Approx. 14.3 mm
  - Status display : LED lamp display
- Display accuracy
  - Green: MAX, MIN, HOLD, COM/SET
  - Red: AL1, AL2, AL3, AL4
  - Refer to Measuring Range Codes.
  - TC:  $\pm(0.1\% \text{ FS}+1 \text{ digit})$  Excluding cold junction temperature compensation accuracy error of thermocouple input
    - Accuracy guarantee not applicable to 400 °C or below of B thermocouple
    - Display value is -100°C or below with K, T thermocouples: Accuracy  $\pm(0.5\% \text{ FS}+1 \text{ digit})$
    - PR40-20 thermocouple: Accuracy  $\pm(0.3\% \text{ FS}+1 \text{ digit})$
    - K thermocouple
      - 10.0–030.0 K: Accuracy  $\pm(0.75\% \text{ FS}+1 \text{ digit})$
      - 30.1–070.0 K: Accuracy  $\pm(0.30\% \text{ FS}+1 \text{ digit})$
      - 70.1–350.0 K: Accuracy  $\pm(0.25\% \text{ FS}+1 \text{ digit})$
    - AuFe-Cr thermocouple: Accuracy  $\pm(0.25\% \text{ FS}+1 \text{ digit})$
  - Pt/JPt:  $\pm(0.1\% \text{ FS}+1 \text{ } ^\circ\text{C}+0.1 \text{ digit})$
  - mV, V:  $\pm(0.1\% \text{ FS}+1 \text{ digit})$
  - mA:  $\pm(0.1\% \text{ FS}+1 \text{ digit})$
- Display accuracy maintaining range : 23 °C  $\pm$  5 °C
- Display resolution : Depends on measuring range and scaling (0.001, 0.01, 0.1, 1)
- Measured value display range : -10–110% of measuring range Refer to Measuring Range Codes.  
(Range of Pt 100: -200–600 °C or -240–680 °C, range of JPt 100: -200–500 °C or -240–570 °C)
- Display updating cycle : 0.1 seconds
- Input scaling function : Scaling possible for linear input (mV, V, mA), inverse scaling possible
  - Scaling range : -9999–30000 digit
  - Span : 10–40000 digit
  - Position of decimal point : None, 1, 2 and 3 digits on the right of decimal point
- Sampling cycle : 0.1 seconds
- PV bias : -9999–10000 digit
- PV slope : 0.500–1.500 times of input value
- PV filter : 0–100 seconds
- PV input operation : Square-root extraction (Only linear input, input low cut 0.0–5.0% FS)  
Linear approximation (Only linear input) 11 points

■ **Setting**

- Set value display : Both set items and parameter are displayed on PV.
- Setting method : By operating 5 keys (**DISP**, **☐**, **▼**, **▲**, **ENT**) on the front panel
- Key rock : OFF, 1–2 (3 level)  
OFF: No key rock  
1: Only key rock screen and mode 0 screen group can be changed.  
2: Only key rock screen can be changed.

■ **Input**

- Input type : Selectable from multi-input (TC, Pt, mV), voltage (V) or current (mA)
- Multi-input
  - Thermocouple** : B, R, S, K, E, J, T, N, PLII, PR40-20, C(WRe5-26), L(DIN43710), U(DIN43710), AuFe-Cr
    - Input resistance : 500 k $\Omega$  minimum
    - External resistance tolerance : 100  $\Omega$  maximum
    - Burnout function : Standard feature (up scale)
    - Cold junction temperature compensation accuracy :  $\pm 1.0 \text{ } ^\circ\text{C}$  (18–28 °C of ambient temperature)
  - R.T.D.** : Pt100/JPt100, 3-wire type
    - Amperage : Approx. 1.1 mA
    - Lead wire tolerance range : 10  $\Omega$  maximum/wire (3 lead wires should have the same resistance.)
  - Voltage (mV)** : -10–10, 0–10, 0–20, 0–50, 10–50, 0–100, -100–100 mV DC
    - Input resistance : 500 k $\Omega$  minimum
- Voltage (V) input : -1–1, 0–1, 0–2, 0–5, 1–5, 0–10, -10–10 V DC
  - Input resistance : 500 k $\Omega$  minimum
- Current (mA) input : 0–20, 4–20 mA DC
  - Receiving impedance : 250  $\Omega$
- Isolation : Not insulated from input and DI but insulated from others
- Input scaling function : Voltage mV, V, current mA range Scalable (Inverse scaling possible)
  - Scaling range : -9999–30000 digit
  - Span : 10–39999 digit
  - Position of decimal point : None, 0.0, 0.00, 0.000
- Sampling cycle : 0.1 seconds
- PV bias : -9999–10000 digit
- PV slope : 0.500–1.500 multiple
- PV filter : 0–100 sec. (filter off by 0 sec. setting)
- Isolation : Isolated except for input and DI

■ **Alarm output (option)**

- Number of output points : Selectable from a contact output 4 points (AL1, AL2, AL3, AL4) or c contact output 2 points (AL1, AL2)
- Alarm types : Selectable from the following 12 types for AL1 – AL4  
The following 12 types can be assigned for each alarm.  
None  
Higher limit absolute value alarm (without latching function)  
Higher limit absolute value alarm (with latching function)  
Lower limit absolute value alarm (without latching function)  
Lower limit absolute value alarm (with latching function)  
Scaleover  
Deviation higher limit value alarm (without latching function)  
Deviation lower limit value alarm (without latching function)  
Deviation higher/lower limit value alarm (without latching function)  
Deviation higher limit value alarm (with latching function)  
Deviation lower limit value alarm (with latching function)  
Deviation higher/lower limit value alarm (with latching function)
- Alarm conditions : About AL2 ... When the AL1 alarm type is [None] or scale over, the [Deviation] alarm can not be selected.  
About AL4 ... If the AL3 alarm type is [None] or scale over, the [Deviation] alarm can not be selected.
- Action method : ON-OFF action
- Hysteresis : 1–9999 digit
- Standby action : Selectable from following 2 types  
Without standby  
Standby (when power is applied)
- Output type/rating : When in a contact: 240 V 2 A (resistive load)  
Between AL1 and AL2, and between AL3 and AL4 are common.  
When in c contact: 240 V 2.5 A (resistive load)
- Output updating cycle : 0.1 seconds
- Isolation : When in a contact, between AL1 and AL2, and between AL3 and AL4 are not insulated but insulated from others.  
When in c contact, between AL1 and AL2 is insulated and insulated from others.

● Alarm range

Code	Name	Setting range	Initial value
HA	Higher limit absolute value alarm	Within range	Range higher limit value
LA	Lower limit absolute value alarm	Within range	Range lower limit value
HA_L	Higher limit absolute value alarm (with latching function)	Within range	Range higher limit value
LA_L	Lower limit absolute value alarm (with latching function)	Within range	Range lower limit value
So	Scaleover	----	----
dHi	Deviation higher limit value alarm	-9999–19999	19999 digit
dLo	Deviation lower limit value alarm	-9999–19999	-9999 digit
dHL	Deviation higher/lower limit value alarm	1–19999	19999 digit
dHi_L	Deviation higher limit value alarm (with latching function)	-9999–19999	19999 digit
dLo_L	Deviation lower limit value alarm (with latching function)	-9999–19999	-9999 digit
dHL_L	Deviation higher/lower limit value alarm (with latching function)	1–19999	19999 digit

■ **External control input (DI)**

- Number of input points : 2 points
- Type of DI allocation : Selectable from the following 4 types for each DI  
NON  
HLD (hold): Maintain the current input value  
RESET (reset): Reset maximum or minimum value  
L\_RS (unlatching)
- Action input : Non voltage contact or open collector (level action) Approx. 5V DC
- Input minimum holding time : 0.1 seconds
- Isolation : Not insulated between DI and input but insulated from others
- **Analog output (optional)**  
Communication function (option) and exclusive choice
- Type : 0–10mV (output resistance 10Ω)  
0–10V (max. load current 2mA)  
4–20mA (max. load resistance 300Ω)
- Resolution : Approx. 1/10000
- Output accuracy : ±0.1%FS for display value
- Scaling : Within measuring range or output range (inverse scaling possible)
- Output updating cycle : 0.1 seconds
- Isolation : Isolation for all

- **Communication function (option)** Exclusive selection with analog output
  - Type of communication : RS-232C, RS-485
  - Communication method : 2-line half duplex start-stop synchronization system
  - Communication distance
    - RS-485 : Max. 500 m (differs according to conditions)
    - RS-232C : Max. 15 m
  - Communication speed : 2400, 4800, 9600, 19200 bps
  - Data format : Selectable from among 7E1, 7E2, 7N1, 7N2, 8E1, 8E2, 8N1, 8N2
  - Communication delay time : 1–100 msec
  - Max. number of connections
    - RS-485 : 32 including host
    - RS-232C : 1
  - Communication address : 1–255
  - Communication code : ASCII, MODBUS RTU binary code only
  - Communication protocol : Shimaden standard protocol / MODBUS ASCII, RTU
  - Other : Start character and BCC operating method can be selected.
  - Communication memory mode : Selectable from among EEPROM, RAM and E\_R
  - Isolation : Isolation for all
  
- **Sensor power supply (option)**
  - Output rating : 24 V DC 50 mA (Two H71/TH71 Series temperature/humidity sensors can be operated.)
  - ON/OFF : Dependent on main body power supply
  - Isolation : Isolation for all
- **General specifications**
  - Data storage : Non-volatile memory (EEPROM)
  - Ambient conditions for operations
    - Temperature : -10–50 °C
    - Humidity : Max. 90% RH (no dew condensation)
    - Elevation : Max. 2000 m above sea level
    - Over voltage category : II
    - Pollution class : 2 (IEC60664)
  - Storage temperature : -20–65 °C
  - Supply voltage : 100–240 V AC±10%, 50/60 Hz
  - Input/noise removal ratio
    - Normal mode minimum 50 dB (50/60 Hz)
    - Common mode minimum 120 dB (50/60 Hz)
  - Insulation resistance
    - Between input/output terminals and power terminal Min. 500 V DC, 20MΩ
    - Between ground and power terminal Min. 500 V DC, 20 MΩ
  - Dielectric strength
    - Between input/output terminals and power terminal 2300 V AC 1 minute
    - Between ground and power terminal 1500 V AC 1 minute
  - Power consumption : Max. 13 VA for 100–240 V AC
  - Applicable standards
    - Safety IEC61010-1 and EN61010-1
    - EN IEC 61010-2-030
    - EMC EN61326-1
    - RoHS directive supported
  - Dust-proof and drip-proof structure : IP66 equivalent
  - Material of case : PPE resin molding (flame resistant grade UL94V-1)
  - External dimensions : H48×W96×D111 mm (in panel 100 mm)
  - Panel thickness : 1.0–4.0 mm
  - Panel cutout : H45×W92 mm
  - Weight : 400 g maximum

ITEM	CODE	SPECIFICATIONS	
SERIES	SD24-	DIN 48x96 Digital Indicator, DI 2 points	
INPUT	8	Universal-input Input resistance: 500 kΩ minimum • Thermocouple • R.T.D.: Pt100/JPt100 • Voltage (mV): -10-10, 0-10, 0-20, 0-50, 10-50, 0-100, -100-100 mV DC Input resistance: 500 kΩ minimum	Refer to "Measuring Range Codes" for details of input type and measuring range.  Voltage mV, V, Current mA range Scaling Possible (inverse scaling possible) Range: -9999-30000 digit Span: 10-39999 digit
	6	Voltage (V) : -1-1, 0-1, 0-2, 0-5, 1-5, 0-10, -10-10 V DC Input resistance: 500 kΩ minimum	
	4	Current (mA) : 0-20, 4-20 mA DC Receiving impedance: 250 Ω	
POWER SUPPLY	90-	100-240V AC±10%, (50/60 Hz)	
ALARM	0	None	
	1	Individually set/output 4 points (a contact)	
	2	Individually set/output 2 points (c contact)	
ANALOG OUTPUT/ COMMUNICATION FUNCTION	00	None	
	03	0-10 mV DC Output resistance: 10 Ω	Scaling Possible (inverse scaling possible) (within measuring range)
	04	4-20 mA DC Resistive load: 300 Ω max.	
	06	0-10 V DC Load current: 2 mA max.	
	50	RS-485	
70	RS-232C		
SENSOR DC POWER SUPPLY	0	Without	
	1	With 24 V DC 50 mA	
REMARKS	0	Without	
	9	With	

● Terminal cover (sold separately)

Model	Fixture
QCR004 (installed if the device is mounted alone)	Two screws of +B tight M2.3x6
QCR005 (installed if a plurality of SD24s and KR17s are mounted vertically)	Four screws of +B tight M2.3x6

**Terminal cover dimensions**

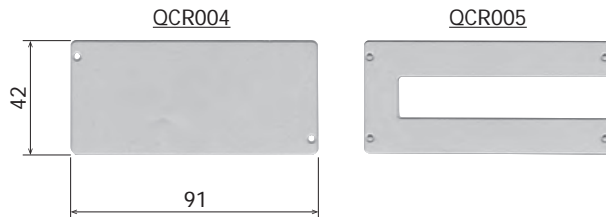

	Input Type	Code	Measuring range		Measuring range (°F)			
			Min	Max	Min	Max		
Thermocouple	B	01 *1	0.0	1800.0	°C	0	3300	
	R	02	0.0	1700.0	°C	0	3100	
	S	03	0.0	1700.0	°C	0	3100	
	K1	04	-100.0	400.0	°C	-150.0	750.0	
	K2	05	0.0	400.0	°C	0.0	750.0	
	K3	06	0.0	800.0	°C	0.0	1500.0	
	K4	07	0.0	1370.0	°C	0.0	2500.0	
	K5	08 *2	-200.0	200.0	°C	-300.0	400.0	
	E	09	0.0	700.0	°C	0.0	1300.0	
	J	10	0.0	600.0	°C	0.0	1100.0	
	T	11 *2	-200.0	200.0	°C	-300.0	400.0	
	N	12	0.0	1300.0	°C	0.0	2300.0	
	PLII	13	0.0	1300.0	°C	0.0	2300.0	
	PR40-20	14 *3	0.0	1800.0	°C	0	3300	
	C (WRe 5-26)	15	0.0	2300.0	°C	0	4200	
	U	16	-200.0	200.0	°C	-300.0	400.0	
	L	17	0.0	600.0	°C	0.0	1100.0	
	K	18 *4	10.0-350.0 (K)					
	AuFe-Cr	19 *5	0.0-350.0 (K)					
R.T.D.	Pt100	31 *6	-200.0	600.0	°C	-300.0	1100.0	
		32	-100.00	100.00	°C	-150.0	200.0	
		33	-100.0	300.0	°C	-150.0	600.0	
		34	-60.00	40.00	°C	-80.00	100.00	
		35	-50.00	50.00	°C	-60.00	120.00	
		36	-40.00	60.00	°C	-40.00	140.00	
		37	-20.00	80.00	°C	0.00	180.00	
		38 *8	0.000	30.000	°C	0.00	80.00	
		39	0.00	50.00	°C	0.00	120.00	
		40	0.00	100.00	°C	0.00	200.00	
	41	0.00	200.00	°C	0.0	400.0		
	42 *9	0.00	300.00	°C	0.0	600.0		
	43	0.0	300.0	°C	0.0	600.0		
	44	0.0	500.0	°C	0.0	1000.0		
	JPt100	45 *7	-200.0	500.0	°C	-300.0	900.0	
		46	-100.00	100.00	°C	-150.0	200.0	
		47	-100.0	300.0	°C	-150.0	600.0	
		48	-60.00	40.00	°C	-80.00	100.0	
		49	-50.00	50.00	°C	-60.00	120.00	
		50	-40.00	60.00	°C	-40.00	140.00	
51		-20.00	80.00	°C	0.00	180.00		
52 *8		0.000	30.000	°C	0.00	80.00		
53		0.00	50.00	°C	0.00	120.00		
54		0.00	100.00	°C	0.00	200.00		
55	0.00	200.00	°C	0.0	400.0			
56 *9	0.00	300.00	°C	0.0	600.0			
57	0.0	300.0	°C	0.0	600.0			
58	0.0	500.0	°C	0.0	900.0			
Voltage (mV)	-10- 10 mV	71	Initial value: 0.00-100.00 Programmable Scaling Lower limit: -9999 Higher limit: 30000 (Span 10-39999 digit) (Inverse scaling possible) Scaleover is displayed for over 32000.					
	0- 10 mV	72						
	0- 20 mV	73						
	0- 50 mV	74						
	10- 50 mV	75						
	0-100 mV	76						
	-100-100 mV	77						
Voltage (V)	-1- 1 V	81	Initial value: 0.00-100.00 Programmable Scaling Lower limit: -9999 Higher limit: 30000 (Span 10-39999 digit) (Inverse scaling possible) Scaleover is displayed for over 32000.					
	0- 1 V	82						
	0- 2 V	83						
	0- 5 V	84						
	1- 5 V	85						
	0- 10 V	86						
	-10- 10 V	87						
Current (mA)	0- 20 mA	94	Initial value: 0.00-100.00 Programmable Scaling Lower limit: -9999 Higher limit: 30000 (Span 10-39999 digit) (Inverse scaling possible) Scaleover is displayed for over 32000.					
	4- 20 mA	95						

**Thermocouple**

- \*1. Accuracy guarantee not applicable to 400 °C or below
- \*2. -100 °C or below: Accuracy ±(0.5% FS+1 digit)
- \*3. Accuracy ±(0.3% FS+1 digit)
- \*4. Accuracy 10.0- 30.0K±(0.75%FS+1 digit)  
30.0- 70.0K±(0.30%FS+1 digit)  
70.0-350.0K±(0.25%FS+1 digit)
- \*5. Accuracy ±(0.25% FS+1 digit)

**R.T.D.**

- \*6. Measured value display range: -240.0-680.0 °C
- \*7. Measured value display range: -240.0-570.0 °C
- \*8. Scaleover is displayed for over 32.000.
- \*9. Scaleover is displayed for over 320.00.

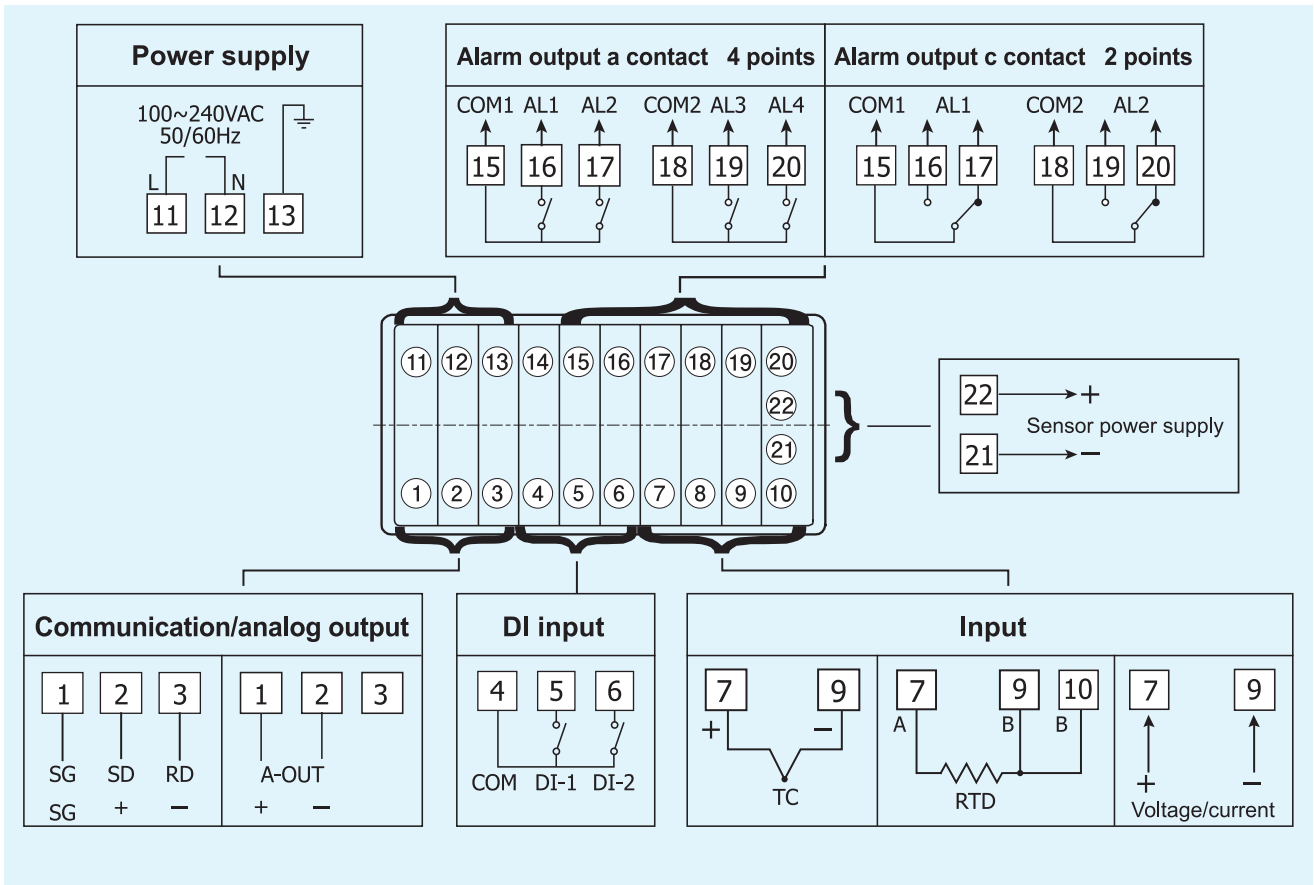

**EXTERNAL DIMENTIONS/PANEL CUTOUT**

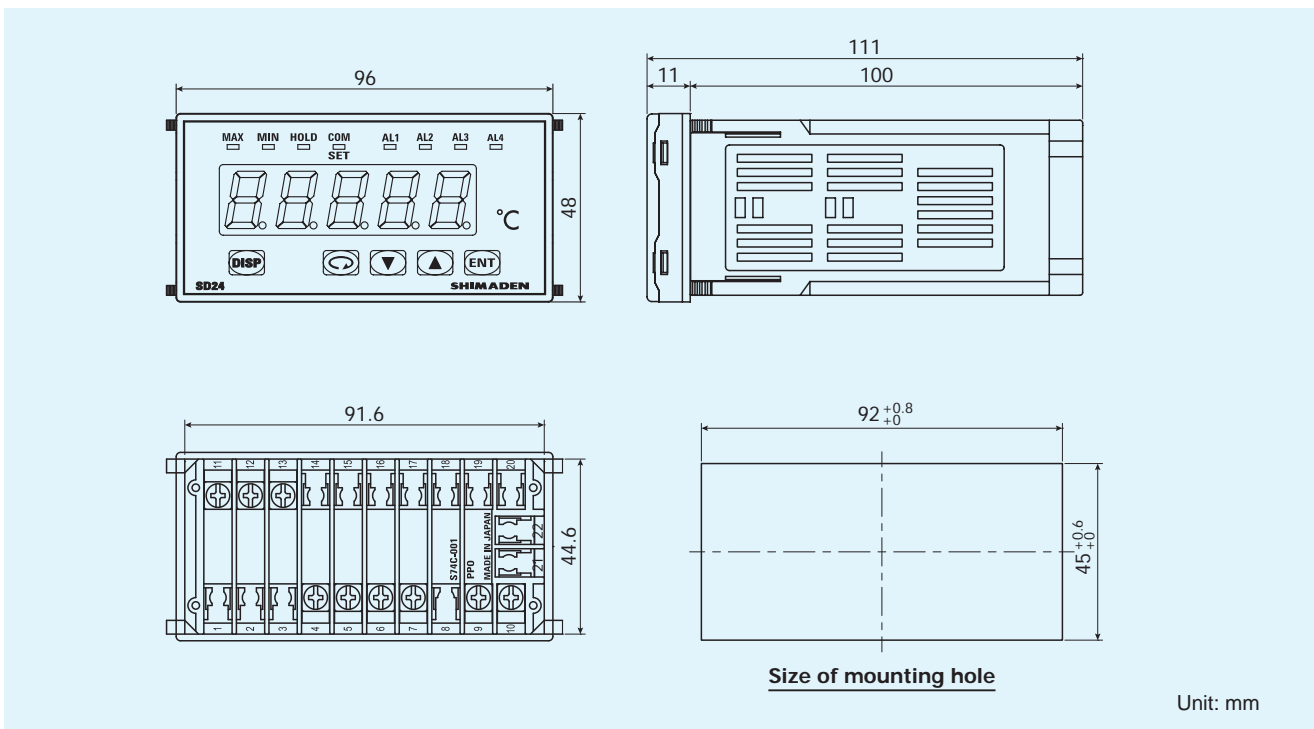



**SPECIFICATIONS**

- No. of switching points : 6
- No. of switching circuits : 2
- Switching operation : Rotary switching
- Applicable signal : Thermocouple, voltage  
(R.T.D. not supported)
- Contact rating : Contact method: Contact slide  
Current: Max. 100 mA DC  
Voltage: Max. 30 V DC  
Contact resistance: Max. 300mΩ
- Operating ambient temperature range : -10–50°C
- Operating ambient humidity range : 90%RH or less (no dew condensation)
- Applicable standard : EMC EN 61326-1  
RoHS directive supported
- Material : PPE resin
- Color : Case: Munsell N1 equivalent  
Front side: Munsell N1 equivalent
- External dimensions : H48 × W96 × D128 mm  
(100 mm depth inside the mounting panel)
- Panel cutout : H45 × W92 mm
- Installation : One-touch mounting through panel cutout
- Panel thickness : 1.0–4.0 mm
- Weight : Approx. 250 g

**ORDERING INFORMATION**

ITEM	CODE	SPECIFICATIONS
SERIES	KR17-	Six-point rotary selector switch
REMARKS	0	Without
	9	With

**TERMINALS, DIMENSIONS, AND PANEL CUTOUT**

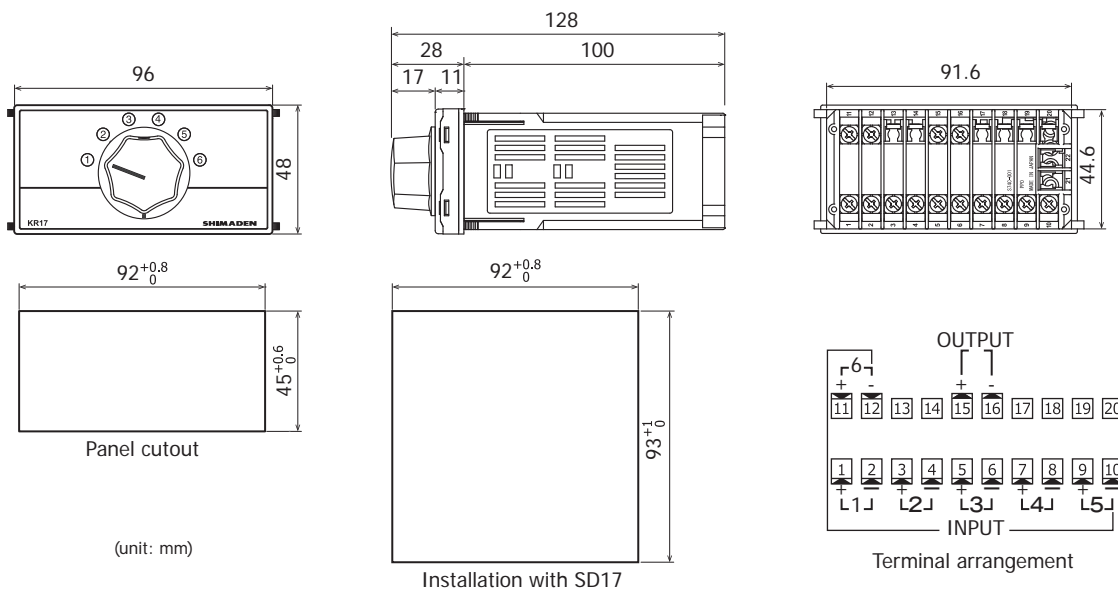

\* The SD24 & KR17 series is designed for the control of temperature, humidity and other physical values of general industrial equipment. (It is not to be used for any purpose which regulates the prevention of serious effects on human life or safety.)



\* If the possibility of loss or damage to your system or property as a result of failure of any part of the process exists, proper safety measures must be made before the instrument is put into use so as to prevent the occurrence of trouble.

Head Office & Saitama Factory  
ISO 9001/ISO 14001 Certification Obtained

(The contents of this brochure are subject to change without notice.)

Temperature and Humidity Control Specialists  
**SHIMADEN CO., LTD.**

Head Office: 2-30-10 Kitamachi, Nerima-Ku, Tokyo 179-0081 Japan  
Phone: +81-3-3931-7891 Fax: +81-3-3931-3089  
E-MAIL: exp-dept@shimaden.co.jp URL: https://www.shimaden.co.jp