

FP93 Series

Program Controller

COMMUNICATION INTERFACE

(RS-232C/RS-485)

INSTRUCTION MANUAL

Thank you for purchasing the Shimaden FP93 controller.
Please check that the delivered product is the correct item you ordered. Please do not begin operating this product until you have read this instruction manual thoroughly and you understand its contents.

This instruction manual describes the communication interface which is an optional function of the FP93 details controller. For details of FP93 performances and parameters, please refer to the separate Instruction manual.

CONTENTS

<p>1. Outline 2</p> <p>2. Specifications 2</p> <p>3. Connecting controller with host computer 3</p> <p> 3-1. RS-232C 3</p> <p> 3-2. RS-485 3</p> <p> 3-3. 3-state output control 4</p> <p>4. Setting of parameters related to communication 4</p> <p> 4-1. Setting communication mode 4</p> <p> 4-2. Setting of communication protocol 4</p> <p> 4-3. Setting of communication address 4</p> <p> 4-4. Setting communication speed 4</p> <p> 4-5. Setting of communication data format 5</p> <p> 4-6. Setting of start character 5</p> <p> 4-7. Setting of communication BCC 5</p> <p> 4-8. Communication delay time 5</p> <p> 4-9. Communication memory mode setting screen 6</p> <p> 4-10. Setting of communication mode type 6</p> <p>5. Outline of standard serial communication protocols 7</p> <p> 5-1. Communication procedure 7</p> <p> (1) Master/slave relation 7</p> <p> (2) Communication procedure 7</p> <p> (3) Time-out 7</p> <p> 5-2. Communication format 7</p> <p> (1) Outline of communication format 7</p> <p> (2) Details of basic format portion I 8</p> <p> (3) Details of basic format portion II 8</p> <p> (4) Basic format portions I and II common condition 9</p> <p> (5) Outline of text portion 9</p> <p> 5-3. Details of read command (R) 10</p> <p> (1) Read command (R) format 10</p> <p> (2) Normal response format to read command (R) 11</p> <p> (3) Abnormal response format to read command (R) 11</p> <p> 5-4. Details of write command (W) / Broadcast Command (B) 12</p> <p> (1) Write command (W) / Broadcast command (B) format 12</p> <p> (2) Normal response format to write command (W) 13</p> <p> (3) Abnormal response format to write command (W) 13</p> <p> (4) Details of Broadcast Command (B) 13</p>	<p> 5-5. Details of response codes 14</p> <p> (1) Type of response codes 14</p> <p> (2) Priority order of response codes 14</p> <p>6. MODBUS protocol overview 15</p> <p> 6-1. Transmission mode overview 15</p> <p> (1) ASCII mode 15</p> <p> (2) RTU mode 15</p> <p> 6-2. Message configuration 15</p> <p> (1) ASCII mode 15</p> <p> (2) RTU mode 15</p> <p> 6-3. Slave address 15</p> <p> 6-4. Function code 16</p> <p> 6-5. Data 16</p> <p> 6-6. Error check 16</p> <p> (1) ASCII mode 16</p> <p> (2) RTU mode 16</p> <p> 6-7. Sample messages 17</p> <p> (1) ASCII mode 17</p> <p> (2) RTU mode 17</p> <p>7. Communication data address 19</p> <p> 7-1. Details of communication data addresses 19</p> <p> (1) Data address and read/write 19</p> <p> (2) Data address and the number of data 19</p> <p> (3) Data 19</p> <p> (4) <Spare> of parameter portion 19</p> <p> (5) Option-related parameters 19</p> <p> (6) Parameters not shown in front panel displays owing to action specifications or setting specifications 19</p> <p> (7) Executing Broadcast 19</p> <p> 7-2. Communication data address list 20</p> <p>8. Supplementary explanation 29</p> <p> 8-1. Table of measuring range codes 29</p> <p> 8-2. Table of EV/DO types 30</p> <p> 8-3. Table of DI types 30</p> <p>9. ASCII code list 31</p>
---	--

1. Outline

There are two types of communication systems, RS-232C and RS-485 employable as the FP93 communication interface. Each of them is capable of setting various data for the FP93 and reading through a personal computer or the like, using signals which comply with EIA standards.

RS-232C and RS-485 are data communication standards established by the Electronic Industries Association of the U.S. (EIA). The standards cover electrical and mechanical aspects, that is, matters related to applicable hardware but not the data transmission procedure of software. Therefore, it is not possible to communicate unconditionally with an apparatus which has the same interface. Hence, users need to have sufficient knowledge of specifications and transmission procedures.

When RS-485 is used, two or more FP93 controllers can be connected to one another. There seems to be a limited number of personal computers, etc., which support this interface, but the use of a line converter for RS-232C <----> RS-485 creates stability.

2. Specifications

The FP93 supports Shimaden standard protocol and MODBUS (RTU/ASCII) communication protocol.

■ Shared by each protocol

Signal level	EIA RS-232C/RS-485-compliant
Communication system	RS-232C: 3-line half duplex system RS-485: 2-line half duplex multidrop system
Synchronization system	Half duplex start-stop synchronization system
Communication distance	RS-232C: Max. 15 m RS-485: Total max. 500 m (differs according to connection conditions)
Communication rate	1200/2400/4800/9600/19200 bps
Transmission procedure	No procedure
Communication delay time	1–100 msec
No. of communication units	RS-232C: 1 unit only RS-485: Up to 31 units (differs according to connection conditions)
Communication address	1–255
Communication memory mode	EEP/RAM/R_E

■ Shimaden standard protocol

Shimaden's own original communication protocol. A list of specifications is provided below.

Data format	Data length: 7 bits, parity: EVEN, stop bits: 1
Data length	Data length: 7 bits, parity: EVEN, stop bits: 2
Parity	Data length: 7 bits, parity: none, stop bits: 1
Stop bits	Data length: 7 bits, parity: none, stop bits: 2
	Data length: 8 bits, parity: EVEN, stop bits: 1
	Data length: 8 bits, parity: EVEN, stop bits: 2
	Data length: 8 bits, parity: none, stop bits: 1
	Data length: 8 bits, parity: none, stop bits: 2
Communication code	ASCII code
Control code	STX_ETX_CR,@:_CR
BCC check	ADD/ADD_two's cmp/XOR/NONE

■ MODBUS protocol

MODBUS protocol is communication protocol developed for PLC by Modicon Inc.

The specifications have been disclosed to the public, but only communication protocol is defined by MODBUS protocol; physical layers such as communication media are not prescribed.

A list of specifications is provided below.

• ASCII mode

Data format	Data length: 7 bits, parity: EVEN, stop bits: 1
Data length	Data length: 7 bits, parity: EVEN, stop bits: 2
Parity	Data length: 7 bits, parity: none, stop bits: 1
Stop bits	Data length: 7 bits, parity: none, stop bits: 2
Communication code	ASCII code
Control code	CRLF
Error check	LRC

• RTU mode

Data format	Data length: 8 bits, parity: EVEN, stop bits: 1
Data length	Data length: 8 bits, parity: EVEN, stop bits: 2
Parity	Data length: 8 bits, parity: none, stop bits: 1
Stop bits	Data length: 8 bits, parity: none, stop bits: 2
Communication code	Binary data
Control code	None
Error check	CRC-16

3. Connecting controller with host computer

The FP93 controller is provided with 3 lines for input and output, i.e., for data transmission, data reception and grounding for signals, not with any other signal lines. Since the controller has no control line, control signals should be taken care of on the host side.

In this instruction, an example of control signal processing methods is shown in drawings (portions surrounded by dotted lines). As the method depends on the system, however, you are advised to refer to the specifications of the host computer for details.

3-1. RS-232C

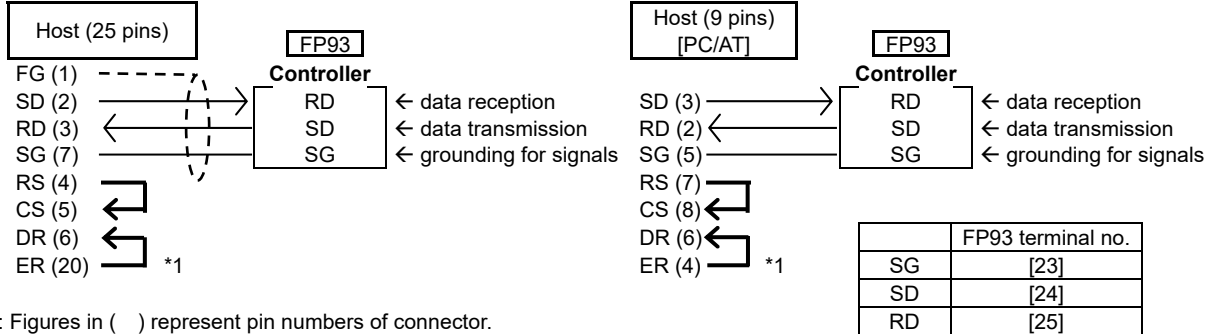

*1: Figures in () represent pin numbers of connector.

3-2. RS-485

The input/output logical level of the FP93 controller is basically as follows:

In the mark state - terminal < + terminal

In the space state - terminal > + terminal

Until immediately before transmission, however, plus terminals and minus terminals of the controller have high impedance and outputs at the above levels are produced immediately before starting transmission. (See 3-3. 3-state output control.)

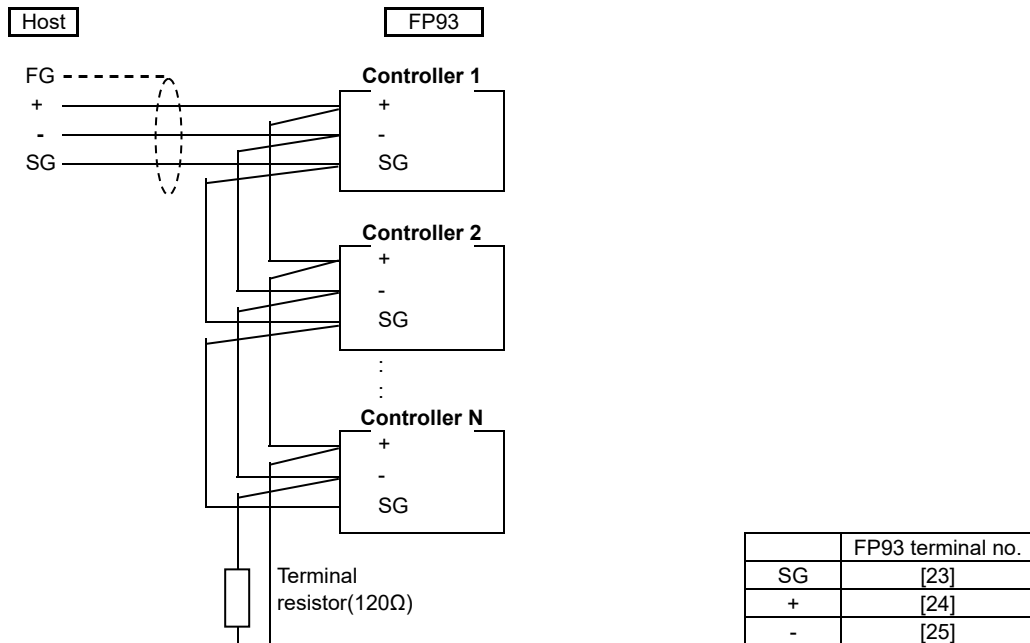

Note1: In the case of RS-485, provide it with the attached terminal resistor of 1/2W, 120Ω across terminals + and if necessary. Nevertheless, it should be provided to only the last controller. If two or more controllers are provided with terminal resistors, correct operation cannot be guaranteed.

3-3. 3-state output control

Since RS-485 is of the multidrop system, transmission output has high impedance always while communication is not carried out or signals are being received in order to avoid collision between transmission signals. It changes from high impedance to the normal output condition immediately before transmission and returns to high impedance control simultaneously when transmission terminates. As the 3-state control is delayed by about 1 msec. (maximum) from the completion of transmission of an end character end bit, however, a few milliseconds' delay should be provided if the host side starts transmission immediately upon reception.

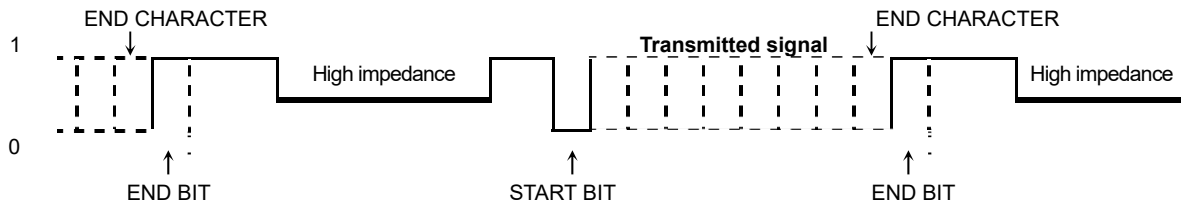

4. Setting of parameters related to communication

There are the following 8 communication-related parameters for the FP93 controller. These parameters are unable to be set or changed by communication; use front key for setting and changing. When parameters are set, see Item (19) Setting Communication of 5-10 of Screen group 5 of the separate instruction manual for the controller and follow the described steps.

4-1. Setting communication mode

5-38

<i>Com</i>	Initial value:	<i>Loc</i> (LOC)
<i>Loc</i>	Setting range:	<i>Loc</i> (LOC), <i>Com</i> (COM)

Code	Effective command	COM lamp
<i>Loc</i> (LOC)	Read	Unlighted
<i>Com</i> (COM)	Read, Write	Lighted

You can select/set communication mode given on the right.
 COM1 enables change from LOC → COM by key operation.
 If COM2 is selected, change from LOC → COM by key operation is not available.

4-2. Setting of communication protocol

5-39

<i>Prot</i>	Initial value:	<i>Shim</i>
<i>Shim</i>	Setting range:	<i>Shim</i> (shim), <i>Asc</i> (asc), <i>Rtu</i> (rtu)

Selection	Communication protocol
<i>Shim</i> (shim)	Shimaden standard protocol
<i>Asc</i> (asc)	MODBUS ASCII MODE
<i>Rtu</i> (rtu)	MODBUS RTU MODE

You can select/set communication protocol given on the right.

4-3. Setting of communication address

5-40

<i>Addr</i>	Initial value:	1
<i>!</i>	Setting range:	1 to 255

While one FP93 controller is connected to one host computer in the case of RS-232C, RS-485 employs the multidrop system allowing it to be connected to a maximum of 32. Actually, however, communication has to be carried out bilaterally. Therefore, each instrument is assigned an address (machine No.) so that only the instrument with the designated address can answer.

Note 1: Although 1 to 255 addresses are available for setting, the number of connectable controllers is 31 maximum.

4-4. Setting communication speed

5-41

<i>bPS</i>	Initial value:	1200 bps
<i>1200</i>	Setting range:	1200, 2400, 4800, 9600, 19200 bps

A communication speed for transferring data to a host is Selected.

4-5. Setting of communication data format

5-42

<i>dAtA</i>
<i>7E1</i>

Initial value: *7E1*

Setting range: 8 types shown in the following table.

You can select format of communication data from among the 8 types given in the following table.

Selection	Data length	Parity	Stop bits	Shimaden standard	MODBUS ASCII mode	MODBUS RTU mode
<i>7E1</i> (7E1)	7 bits	EVEN	1 bit	○	○	—
<i>7E2</i> (7E2)	7 bits	EVEN	2 bits	○	○	—
<i>7n1</i> (7N1)	7 bits	None	1 bit	○	○	—
<i>7n2</i> (7N2)	7 bits	None	2 bits	○	○	—
<i>8E1</i> (8E1)	8 bits	EVEN	1 bit	○	—	○
<i>8E2</i> (8E2)	8 bits	EVEN	2 bits	○	—	○
<i>8n1</i> (8N1)	8 bits	None	1 bit	○	—	○
<i>8n2</i> (8N2)	8 bits	None	2 bits	○	—	○

○: Supported
—: Not Supported

4-6. Setting of start character

5-43

<i>ScHr</i>
<i>5E4</i>

Initial value: *5E4* (STX)

Setting range: *5E4* (STX), *At@* (@)

Code	Start character	Text end character	End character
<i>5E4</i> (STX)	STX (02H)	ETX (03H)	CR (0DH)
<i>At@</i> (@)	"@" (40H)	":" (3AH)	CR (0DH)

Select a control code to be used.

This parameter is valid only when Shimaden standard protocol is used.

4-7. Setting of communication BCC

5-44

<i>bcc</i>
<i>1</i>

Initial value: 1

Setting range: 1 to 4

Code	BCC operation method
1	Addition
2	Addition + 2's complement
3	XOR
4	None

Select a BCC operation method to be used in BCC checking.

Not displayed except for when Shimaden protocol has been selected.

4-8. Communication delay time

5-45

<i>dELy</i>
<i>20</i>

Initial value: 20

Setting range: 1 to 100 msec

Set the length of delay time from receipt of a communication command to transmission.

Note 1: When RS-485 is used, some converters take longer time for 3-state control than others and it may lead to signal collision. This can be avoided by increasing delay time. Care should be taken particularly when the communication rate is slow (1200 bps or 2400 bps).

Note 2: Actual delay time from receipt of a communication command to transmission is a total of the above-mentioned delay time and command processing time by software. Particularly for writing commands, about 400 msec. may be taken for processing.

4-9. Communication memory mode setting screen

5-46

$\bar{E}E\bar{E}$	Initial value: EEP (EEP)
EEP	Setting range: EEP (EEP), $rA\bar{r}$ (Ram), r_E (r_E)

Since the number of writing cycles of volatile memory EEPROM used in FP93 is limited, the life of EEPROM is shortened if SV data or the like are rewritten frequently by communication. To prevent this, in case data are to be rewritten frequently by communication, set the RAM mode in which only RAM data are rewritten without rewriting EEPROM, thereby maintaining the life of EEPROM as long as possible.

Code	Description
EEP (EEP)	In this mode EEPROM data are also rewritten every time data are changed by communication. Accordingly, data are maintained when power is turned off.
$rA\bar{r}$ (Ram)	In this mode only RAM data are rewritten but EEPROM data are not when data are changed by communication. Therefore, RAM data are deleted when power is turned off. Upon applying power again, operation starts with data stored in EEPROM.
r_E (r_E)	FIX SV, OUT, STEP SV and START SV data are written in RAM and others in EEPROM.

Note: On RAM as communication memory mode

When the RAM mode is selected, all of set data are written in RAM. It should be noted that nonconformity of set data arises from such a pattern as shown below:

On the assumption that 05 is set for the input range (K 0.0 to 800.0°C):

- Through communication, event code is changed from higher deviation value to higher absolute value.
(This change is recorded in RAM.)
- Communication point setting is changed from COM to LOC.
- The event action point setting is changed from 800.0 to 700.0 by key operation.
(Since this is done in LOC mode, the changed data is written in EEPROM.)
- Power supply is interrupted. Then power is applied again.
- The event code record in RAM is cleared and higher deviation value is read from EEPROM.
- Since 700.0 is written as event action point in EEPROM 700.0 is read.
- The setting range of higher deviation values are actually from -1999 to 2000 digit but the above steps result in the setting of an impossible value of 7000 digit.
Such being the case, for proper control, you have to set correct data again.

4-10. Setting of communication mode type

5-47

$\bar{C}O\bar{N}1$	Initial value: $CO\bar{N}1$ (COM1)
$CO\bar{N}1$	Setting range: $CO\bar{N}1$ (COM1), $CO\bar{N}2$ (COM2)

Select communication mode type.

Set to COM1 if you want to enable key operation while writing by communication.

Communication mode types	$CO\bar{N}1$ (COM1)		$CO\bar{N}2$ (COM2)	
	COM	LOC	COM	LOC
Key operation	Available	Available	Not available	Available
Communication writing	Available	Available	Available	Not available

If "communication mode type" is modified by communication command, configuration is as follows.

Communications mode	LOC	COM
Communication writing	COM1 ⇒ COM2 available	COM1 ⇒ COM2 available
	COM2 ⇒ COM1 not available	COM2 ⇒ COM1 available

5. Outline of standard serial communication protocols

In the FP93, the Shimaden standard serial communication protocol. This enables you to acquire and/or change data from instruments, which employ the standard protocol, by using the same format.

5-1. Communication procedure

(1) Master/slave relation

- The master side mean personal computer or PLC (host).
- The slave side means the FP93 controller.
- A communication command from the master side starts communication and a response from the slave side terminates it. If abnormality such as a communication format error or a BCC error occurs, there will be no response. No response is sent, either, to broadcast instruction.

(2) Communication procedure

Communication goes on by transferring the transmission right to each other in the pattern that the slave side responds to the master side.

(3) Time-out

In case receipt of the end character does not complete within one second after receiving the start character, it is time-out and the controller is automatically put in the state of waiting for another command (a new start character). Accordingly, the host side should set one second minimum as the time-out duration.

5-2. Communication format

Because FP93 supports various types of protocol, you can make a wide range of selections by communication format (control code and BCC operating method) and communication data format (data bit length, parity or no parity, stop bit length). For the sake of convenience and in order to avoid confusion when making communication settings, however, we recommend using the following format.

	Recommended format	
Control code	STX_ETX_CR	
BCC operation method	ADD	
Communication data format	7E1	8N1

(1) Outline of communication format

The communication format comprises the basic format portion I, the text portion and the basic format portion II.

1) Communication command format

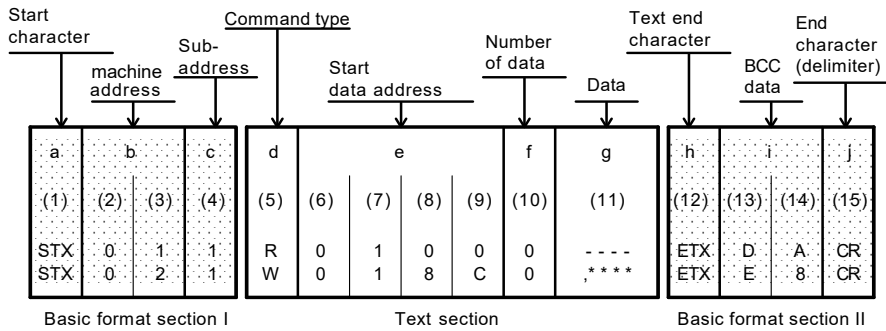

2) Response format

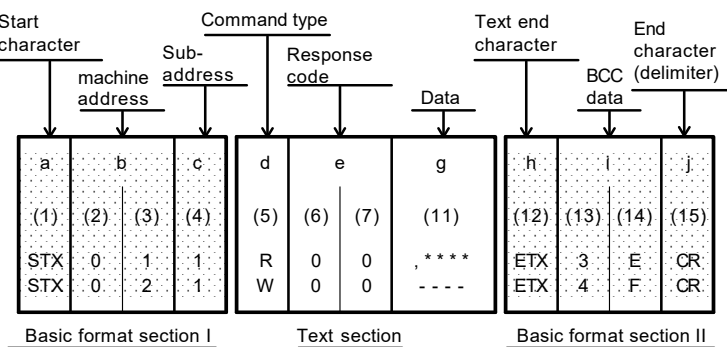

- The basic format portions I and II are common to commands (R), write commands (W) and responses. Nonetheless, in BCC data of i (13, 14) operation result data is inserted each time.
- The text portion differs depending on the types of commands, data addresses, responses, etc.

(2) Details of basic format portion I

a: Start character [(1): 1 digit/STX (02H) or "@" (40H)]

- Indicates the start of communication bloc.
- Upon receipt of start character, it is judged as the first of a new communication bloc.
- A start character and a text end character are selected in a pair.
(See 4-6. Setting of start character)

Select with STX (02H) ····ETX (03H), or select with "@" (40H) ···· ":" (3AH).

b: Machine address [(2), (3): 2 digits]

- Designates the instrument to communicate with.
- Address can be designated in a range from 1 to 255 (10 numerals).
- Binary 8-bit data (1: 0000 0001 to 99: 0110 0011) are split into high position 4 bits and low position 4 bits, and converted to ASCII data.

(2): ASCII data converted from the high position 4 bits

(3): ASCII data converted from the low position 4 bits

- Since the machine address=0 (30H, 30H) is used for broadcast instruction, it cannot be used as a machine address.

c: Sub-address [(4): 1 digit]

- As the FP93 are single loop controllers, their sub-address is fixed to (4) = 1 (31H).
Designation of any other address is taken as a sub-address error and here will be no response.

(3) Details of basic format portion II

h: Text end character [(12): 1 digit/ETX (03H)] or ":" (3AH)]

- Indicates that the text portion terminates right before this character.

i: BCC data [(13), (14): 2 digits]

- BCC (Block Check Character) checks if there is any error in communication.
- There will be no response if BCC operation results in a BCC error.
- The following indicates the 4 types of BCC operation: (Type of BCC operation can be set on the front screen.)

(1) ADD

Add operation is performed on every 1 character of ASCII data (1 byte) from the start character (1) through the text end character (12).

(2) ADD + 2' complement

Add operation is performed on every 1 character of ASCII data (1 byte) from the start character (1) through the text end character (12), and two's complement of the low position 1 byte of the operation result is taken.

(3) Exclusive OR

XOR (exclusive OR) operation is performed on every 1 character of ASCII data (1 byte) from the machine address (2) right after the start character through the text end character (12).

(4) None

BCC operation is not performed. ((13), (14) are omitted.)

- Regardless of the length of data bits (7 or 8), operation is carried out with 1 byte (8 bits) as a unit.
- The lower position 1-byte data obtained as result of operations mentioned above is split into high position 4 bits and low position 4 bits and converted to ASCII codes.

(13): ASCII data converted from high position 4 bits

(14): ASCII data converted from low position 4 bits

Example 1: In the case of a read command (R) with ADD set for BCC

(1)	(2)	(3)	(4)	(5)	(6)	(7)	(8)	(9)	(10)	(12)	(13)	(14)	(15)
STX	0	1	1	R	0	1	0	0	0	ETX	D	A	CR

$02H + 30H + 31H + 31H + 52H + 30H + 31H + 30H + 30H + 30H + 03H = 1DAH$

Low position 1 byte of result of addition (1DAH) = DAH

(13): "D" = 44H, (14): "A" = 41H

Example 2: In the case of a read command (R) with ADD + 2's complement for BCC

(1)	(2)	(3)	(4)	(5)	(6)	(7)	(8)	(9)	(10)	(12)	(13)	(14)	(15)
STX	0	1	1	R	0	1	0	0	0	ETX	2	6	CR

$02H + 30H + 31H + 31H + 52H + 30H + 31H + 30H + 30H + 30H + 03H = 1DAH$

Low position 1 byte of result of addition (1DAH) = DAH

Two's complement of low position 1 byte (DAH) = 26H

(13): "2" = 32H, (14): "6" = 36H

Example 3 In the case of a read command (R) with XOR set for BCC

(1)	(2)	(3)	(4)	(5)	(6)	(7)	(8)	(9)	(10)	(12)	(13)	(14)	(15)
STX	0	1	1	R	0	1	0	0	0	ETX	5	0	CR

$$02H \oplus 30H \oplus 31H \oplus 31H \oplus 52H \oplus 30H \oplus 31H \oplus 30H \oplus 30H \oplus 03H = 50H$$

⊕ = XOR (exclusive OR)

Low position 1 byte of result of operation (50H) = 50H
 (13): "5" = 35H, (14): "0" = 30H

j: End character (delimiter) [(15): 1 digit/CR]

- Indicates that it is the end of the communication message.

(4) Basic format portions I and II common condition

- 1) if abnormalities as listed below are found in the basic format portions, there will be no response:
 - There is a hardware error.
 - Machine address or sub-address is different from that of the designated instrument.
 - Any of the characters specified in the above communication format is not in its specified position.
 - The result of BCC operation differs from BCC data.
- 2) Conversion of data: Every 4 bits of binary data are converted to ASCII data.
- 3) <A> through <F> in hexadecimal numbers are converted to ASCII data by using capital letters.

(5) Outline of text portion

The text portion changes according to the types of commands and responses.
 For details of the text portion, see 5-3. Details of read commands (R) and 5-4. Details of write commands (W).

d: Type of commands [(5): 1 digit]

- **"R"** (52H/capital letter) : Indicates that it is a read command or a response to read command.
Used to read (take) various data of FP93 from personal computer, PLC, etc.
- **"W"** (57H/uppercase character): : Indicates that it is a Write command or a response to write command.
Used to write (change) various data in FP93 from personal computer, PLC, etc.
- **"B"** (42H/uppercase character): : Indicates that it is a broadcast command.
- There is no response when any other abnormal character besides **"R"** and **"W"** is recognized.

e: Starting address [(6), (7), (8), (9): 4 digits]

- For a read command (R) or a write command (W), designates a starting address of where to read from or write in.
- A starting address is designated by binary number 16-bit (1 word/0 to 65535) data.
- 16-bit data are split into 4-bit groups and converted to ASCII data.

Binary (16 bits)	D15,D14,D13,D12 0 0 0 0	D11,D10,D9,D8 0 0 0 1	D7, D6, D5, D4 1 0 0 0	D3, D2, D1, D0 1 1 0 0
Hex	0H "0"	1H "1"	8H "8"	CH "C"
ASCII data	30H (6)	31H (7)	38H (8)	43H (9)

- For data addresses, refer to 6. Details of communication data addresses.

f: The number of data [(10): 1 digit]

- For a read command (R) or a write command (W), designates the number of data to be read or written.
- The number of data is designated in the following range by converting binary number 4-bit data to ASCII data:
"0" (30H) (one) to "9" (39H) (ten)
- For write commands, the number is fixed to "0" (30H) (one).
- The actual number of data is as follows: <the number of data = designated numerical value of data + 1>

g: Data [(11): The number of digits depends on the number of data]

- Designates data to be written (data to be changed) for write command (W) or data to be read for response to a read command (R).
- The data format is as follows:

g (11)

“ , ” 2CH	1st data				2nd data				nth data			
	High position 1st digit	2nd digit	3rd digit	Low position 4th digit	High position 1st digit	2nd digit	3rd digit	Low position 4th digit	High position 1st digit	2nd digit	3rd digit	Lower position 4th digit

- Data is always preceded by comma (“ , ” 2CH) to show the subsequent portion is data.
- No punctuation code is used between data and data.
- The number of data is determined by the number of data (f: (10)) of the communication command format.
- Each data is expressed by binary 16 bits (1 word), excluding a decimal point, as a unit. The position of the decimal point is fixed in each data.
- 16-bit data are split into 4-bit groups and respectively converted to ASCII data.
- For details of data, see “5-3. Details of read command (R)” and “5-4. Details of write command (W).”

e: Response code [(6), (7): 2 digits]

- Designates a response code to a read command (R) or a write command (W).
- Binary 8-bit data (0 to 255) are split to high position 4 bits and low position 4 bits and respectively converted to ASCII data.

(6): ASCII data converted from high position 4 bits.
 (7): ASCII data converted from low position 4 bits.

- In the case of normal response, “0” (30H), “0” (30H) is designated.
- In the case of abnormal response, abnormal code No. is converted to ASCII data and designated.
- For details of response codes, refer to “5-5. Details of response codes.”

5-3. Details of read command (R)

Read command (R) used by a personal computer, PLC or the like to read (take) various data in FP93.

(1) Read command (R) format

- The format of the text portion of a read command (R) is shown below:
 (The basic format portions I and II are common to all commands and responses.)

Text section

d	e				f
(5)	(6)	(7)	(8)	(9)	(10)
R	0	4	0	0	4
52H	30H	34H	30H	30H	34H

d: Indicates that it is a read command.
 e: Designates the starting address of data to be read.
 f: Designates how many data (words) are to be read from the starting address.

- The above command means the following:

Starting address of data to be read = 0400H (hexadecimal)
 = 0000 0100 0000 0000 (binary)

The number of data to be read = 4H (Hexadecimal)
 = 0100 (Binary)
 = 4 (decimal)

(The actual number of data) = 5 (4 + 1)

Thus, the command designates reading of 5 data from the data address 0400H.

(2) Normal response format to read command (R)

- The following is the normal response format (text section) to the Read commands (R).
(The basic format portions I and II are common to all commands and responses.)

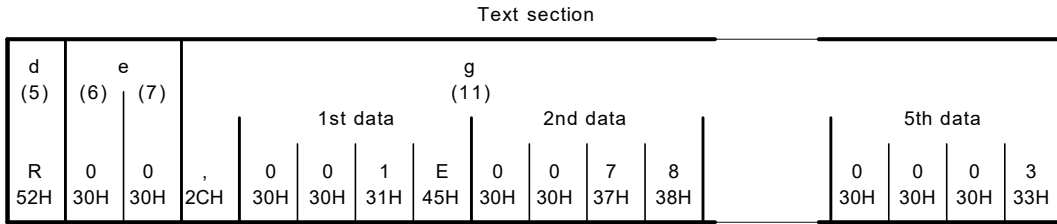

- d ((5)) : <R (52H)> indicates that it is a response to a read command (R) is inserted.
- e ((6) to (7)): The response code <0 0 (30H, 30H)> indicates that is a normal response to the read command (R) is inserted.
- g ((11)) : Response data to the read command is inserted.
The data format is as follows:
 - To begin with <, (2CH)> indicates the head of data is inserted.
 - Then, data in the number according to <the number of data to be read> are inserted one by one, starting from the <data of starting address for reading>.
 - Nothing is inserted between the respective data.
 - The respective data comprise binary 16-bit (1 word) data, excluding a decimal point, and are converted, 4 bits as a unit, to ASCII data and inserted.
 - The position of decimal point is fixed in the respective data.
 - The number of characters of response data is as follows:
Number of characters = 1 + 4 x number of data to be read.
- To the above read command (R), the following data are returned as a response:

		Data address 16 bits (1 word)	Data 16 bits (1 word)		
		Hexadecimal	Hexadecimal	Decimal	
Read starting address (0400H)	→	0	0400	001E	30
		1	0401	0078	120
		2	0402	001E	30
		3	0403	0000	0
		4	0404	0003	3

The number of data
To be read (4H: 5)

Thus, the data mentioned above can be read.

(3) Abnormal response format to read command (R)

- The following is the abnormal response format (text portion) to read commands (R):
(The basic format portions I and II are common to all commands and responses.)

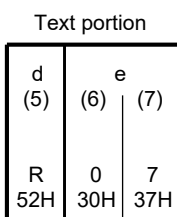

- d ((5)) : <R (52H)> indicates that it is a response to a read command (R) is inserted.
- e ((6) to (7)): A response code indicates that it is an abnormal response to read command (R) is inserted.
- For details of abnormal response code, refer to 5-5. Details of response codes.
- No response data are inserted in an abnormal response.

5-4. Details of write command (W) / Broadcast Command (B)

A write command (W) is used by a personal computer, PLC, etc., to write (change) various data in FP93.

If communication mode type is COM2, the communication mode parameter must be changed to communication mode when using the write command. As this parameter is unable to be changed from LOC to COM by front key operation, however, the change should be made by the following command transmission: (In the case of address = 01, sub address = 1, start character = STX and BBC operation = addition).

■ Command format

STX	0	1	1	W	0	1	8	C	0	,	0	0	0	1	ETX	E	7	CR
02H	30H	31H	31H	57H	30H	31H	38H	43H	30H	2CH	30H	30H	30H	31H	03H	45H	37H	0DH

When a normal response is returned for the command given above, the COM LED on the front panel lights and mode type changes to communication mode.

(1) Write command (W) / Broadcast command (B) format

- The following is the text format of a write command.
(The basic format portions I and II are common to all commands and responses.)

Text Portion

d	e				f	g				
(5)	(6)	(7)	(8)	(9)	(10)	(11)				
W/B	0	4	0	0	0	Data to be written				
57H/42H	30H	34H	30H	30H	30H	2CH	30H	30H	32H	38H

- d ((5)) : Shows that it is a write command / Broadcast.
Shows "W" (57H)
Shows "B" (42H)
- e ((6) to (9)): Designates starting address of data to written (change).
- f ((10)) : Designates the number of data to be written (change).
- g ((11)) : Designates data to be written (change).
 - To begin with <, (2CH)> indicating the head of data is inserted.
 - Then, data to be written (changed) are inserted.
 - The respective data comprise binary 16-bit (1 word) data, excluding a decimal point, and are converted, 4 bits as a unit, to ASCII data and inserted.
 - The position of decimal point is fixed in the respective data.
- The above command is as following:

Starting address of data to be written	= 0400H	(Hexadecimal)
	= 0000 0100 0000 0000	(Binary)
Number of write data	= 0H	(Hexadecimal)
	= 0000	(Binary)
	= 0	(Decimal)
(Actual number of data)	= one (0 + 1)	
Data to be written	= 0028H	(Hexadecimal)
	= 0000 0000 0010 1000	(Binary)
	= 40	(Decimal)

Thus, writing (changing) of data address 0400H and one piece of data (40: decimal) is designated.

Data address		Data	
16 bits (1 word)		16 bits (1 word)	
Hexadecimal	Decimal	Hexadecimal	Decimal
0400	1024	0028	40
0401	1025	0078	120
0402	1026	001E	30

Address (400H) → 0
The number of data to be written: one (01)

(2) Normal response format to write command (W)

- The following is the normal response format (text section) to a write command (W). (The basic format portions I and II are common to all commands and responses.)

Text portion

d (5)	e (6) (7)	
W 57H	0 30H	0 30H

- d ((5)) : <W (57H)> indicates that it is a response to a write command (W) is inserted.
- e ((6) to (7)): A response code <0 0 (30H and 30H)> indicates that it is a normal response to the write command (W) is inserted.

(3) Abnormal response format to write command (W)

- The following shows is the abnormal response format (text portion) to a write command (W). (The basic format portions I and II are common to all commands and responses.)

Text portion

d (5)	e (6) (7)	
W 57H	0 30H	9 39H

- d ((5)) : <W (57H)> indicates that it is a response to a write command (W) is inserted.
- e ((6) to (7)): A response code indicates that it is an abnormal response to the write command (W) is inserted.
- For details of abnormal codes, refer to 5-5 Details. of response codes.

(4) Details of Broadcast Command (B)

- Broadcast command (B) is used to simultaneously write (change) data from the master computer or PLC to all devices supporting Broadcast command.
- There is no communication response in Broadcast command.

■ Broadcast Command Format

For details on parameters in which broadcast is possible, refer to “7. Communication Data Address List.”

Example AT (auto-tuning) execution

Device address: 00, Sub-address: 1

STX	0	0	1	B	0	1	8	4	,	0	0	0	1	ETX	9	2	CR
02H	30H	30H	31H	42H	30H	31H	38H	34H	2CH	30H	30H	30H	31H	03H	39H	32H	0DH

5-5. Details of response codes

(1) Type of response codes

- Communication responses to the read command (R) and write command (W) always contain response codes.
- Response codes are divided broadly into two types:

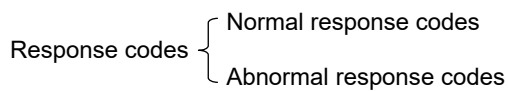

- A response code comprises 8 bits data of binary numbers (0 to 255).
- The types of response codes are listed below:

A List of Response Code

Response Code		Type of code	Description
Binary numbers	ASCII		
0000 0000	“0”, “0”: 30H, 30H	Normal response	Normal response to read command (R) or write command (W)
0000 0001	“0”, “1”: 30H, 31H	Hardware error in text portion	When hardware error such as framing overrun or parity error has been detected in data in the text portion.
0000 0111	“0”, “7”: 30H, 37H	Format error text portion	Format of text portion is different from what was fixed.
0000 1000	“0”, “8”: 30H, 38H	Error in data of text portion, data address or the number of data	Data of text portion is not in fixed format, or data address or the number of data is different from designated one.
0000 1001	“0”, “9”: 30H, 39H	Data error	Data to be written get beyond range in which Setting is possible.
0000 1010	“0”, “A”: 30H, 41H	Execution command error	Execution command (such as AT command) was received in conditions where that execution command is not acceptable.
0000 1011	“0”, “B”: 30H, 42H	Write mode error	Some types of data are unable to be changed at certain points in time. Write command containing such data was received at such a time.
0000 1100	“0”, “C”: 30H, 43H	Specification or option error	Write command containing data of specification or option which was not added was received.

(2) Priority order of response codes

- The smaller the value of the response code, the higher the priority of the response code;
When two or more response codes are generated, a response code of higher order is returned.

6. MODBUS protocol overview

MODBUS protocol includes ASCII and RTU transmission modes.

6-1. Transmission mode overview

(1) ASCII mode

Eight-bit binary data in the command is divided into top and bottom 4 bits and is transmitted as ASCII characters in hexadecimal notation.

■ Data configuration

Data Format : Selection of 7E1, 7E2, 7N1 or 7N2
Error check : LRC (horizontal redundancy test)
Data transmission interval : Max. 1 sec.

(2) RTU mode

Eight-bit binary data in the command is transmitted as is.

■ Data configuration

Data Format : Selection of 8E1, 8E2, 8N1 or 8N2
Error check : CRC-16 (cycle redundancy test)
Data transmission interval : 3.5 character transmission time or less

6-2. Message configuration

(1) ASCII mode

Configured to begin with start character [: (colon) (3AH)] and end with end character [CR (carriage return) (0DH)] + [LF (line feed) (0AH)].

Header (:)	Slave address	Function code	Data	Error check LRC	Delimiter (CR)	Delimiter (LF)
------------	---------------	---------------	------	-----------------	----------------	----------------

(2) RTU mode

Configured to begin after idling over the 3.5 character transmission time and end when idling over the 3.5 character transmission time elapses.

Idle 3.5 character	Slave address	Function code	Data	Error check CRC	Idle 3.5 character
--------------------	---------------	---------------	------	-----------------	--------------------

6-3. Slave address

Slave addresses are slave machine numbers 1–255.

The master can identify slaves individually by specifying slave address by request message.

The master is informed which slave is responding by setting slave address and returning it for the response message on the slave side.

Slave address 0 is a broadcast address and can specify all the slaves. In the event of broadcast, the slave side does not return the response.

6-4. Function code

The function code specifies the type of action to the slave.

Function code	Details
03 (03H)	Slave setting value and information read
06 (06H)	Slave write

The function code is also used to show if the response is normal (affirmative response) or what sort of error (negative response) is occurring when the slave returns a response message to the master.

With affirmative response, the original function code is set and returned.

With a negative response, the highest bit of the original function code is set to "1" and returned.

If for instance the function code is mistakenly set to 10H and a request message is sent to the slave, because it is a nonexistent function code, the highest bit is set to "1" and returned as 90H.

Also for a negative response, in order to inform the master what sort of error has occurred, an abnormal code is set in the data of the response message and sent.

Error code	Details
1 (01H)	Illegal function (nonexistent function)
2 (02H)	Illegal data address (nonexistent data address)
3 (03H)	Illegal data value (value outside setting range)

6-5. Data

Configuration of data differs according to the function code.

With request messages from master machines, it consists of data items, number of data items and set data.

With response messages from slave machines, it consists of number of bytes relative to the request and data, or abnormal code, etc., for negative response. The valid range of data is -32768 to 32767.

6-6. Error check

The error check method differs according to transmission mode.

(1) ASCII mode

Error check in the ASCII mode calculates LRC from slave address to final data item; the 8-bit calculated data is converted to ASCII character 2 character and set following the data.

■ LRC calculation method

1. Prepare a message in RTU mode.
2. Add from slave address to final data item and substitute for X.
3. Take the complement of X (bit inverse) and substitute for X.
4. Add 1 to X and substitute for X.
5. Set X as LRC following the data.
6. Convert message to ASCII characters.

(2) RTU mode

Error check in the RTU mode calculates CRC-16 from slave address to final data item; the 16-bit calculated data is set in bottom/top order following the data.

■ CRC-16 calculation method

CRC formula divides data to be sent by generating polynomial and the remainder is added to the end of the data and sent.

Generating polynomial: $X^{16} + X^{15} + X^2 + 1$

1. Initialize CRC data (X). (FFFFH)
2. Take the first data item and exclusive OR (XOR) and substitute for X.
3. Shift X 1 bit to the right and substitute for X.
4. If carry is enabled by shifting, take XOR by results X of (3) and fixed value (A001H) and substitute for X.
If carry is not enabled, proceed to 5.
5. Repeat steps 3 and 4 until shifted 8 times.
6. Take the next data item and XOR of X and substitute for X.
7. Repeat steps 3–5.
8. Repeat steps 3–5 up to the final data item.

X is set as CRC-16 in message following the data in bottom/top order.

6-7. Sample messages

(1) ASCII mode

■ Machine No. 1, SV read

- Request message from master machine

Header	Slave address	Function code	Data address	No. of data items	Error check LRC	Delimiter
(:)	(01H)	(03H)	(0300H)	(0001H)	(F8H)	(CR · LF)
1	2	2	4	4	2	2

← No. of characters (17)

- Response message from slave when normal (SV = 10.0°C).

Header	Slave address	Function code	No. of response bytes	Data	Error check LRC	Delimiter
(:)	(01H)	(03H)	(02H)	(0064H)	(96H)	(CR · LF)
1	2	2	2	4	2	2

← No. of characters (15)

- Response message from slave when abnormal (data item mistaken)

Header	Slave address	Function code	Error code	Error check LRC	Delimiter
(:)	(01H)	(83H)	(02H)	(7AH)	(CR · LF)
1	2	2	2	2	2

← No. of characters (11)

With response messages when an error occurs, "1" is set as the highest bit of the function code (83H). Abnormal code 02H is returned (nonexistent data address) as response message of error contents.

■ Machine No. 1, SV = 10.0°C write

- Request message from master machine

Header	Slave address	Function code	Data address	Data	Error check LRC	Delimiter
(:)	(01H)	(06H)	(0300H)	(0064H)	(92H)	(CR · LF)
1	2	2	4	4	2	2

← No. of characters (17)

- Response message from slave when normal (SV = 10.0°C).

Header	Slave address	Function code	Data address	Data	Error check LRC	Delimiter
(:)	(01H)	(06H)	(0300H)	(0064H)	(92H)	(CR · LF)
1	2	2	4	4	2	2

← No. of characters (17)

- Response message from slave when abnormal (value set outside range)

Header	Slave address	Function code	Error code	Error check LRC	Delimiter
(:)	(01H)	(86H)	(03H)	(76H)	(CR · LF)
1	2	2	2	2	2

← No. of characters (11)

With response messages when an error occurs, "1" is set as the highest bit of the function code (86H). Abnormal code 03H is returned (value set outside range) as response message of error contents.

(2) RTU mode

■ Machine No. 1, SV read

- Request message from master machine

Idle 3.5 character	Slave address	Function code	Data address	No. of data items	Error check CRC	Idle 3.5 character
	(01H)	(03H)	(0300H)	(0001H)	(844EH)	
	1	1	2	2	2	

← No. of characters (8)

- Response message from slave when normal (SV = 10.0°C).

Idle 3.5 character	Slave address	Function code	No. of response bytes	Data	Error check CRC	Idle 3.5 character
	(01H)	(03H)	(02H)	(0064H)	(B9AFH)	
	1	1	1	2	2	

← No. of characters (7)

- Response message from slave when abnormal (data item mistaken)

Idle 3.5 character	Slave address (01H)	Function code (83H)	Error code (02H)	Error check LRC (C0F1H)	Idle 3.5 character
	1	1	1	2	

← No. of characters (5)

With response messages when an error occurs, "1" is set as the highest bit of the function code (83H). Abnormal code 02H is returned (nonexistent data address) as response message of error contents.

■ Machine No. 1, SV 10.0°C setting

- Request message from master machine

Idle 3.5 character	Slave address (01H)	Function code (06H)	Data address (0300H)	Data (0064H)	Error check CRC (8865H)	Idle 3.5 character
	1	1	2	2	2	

← No. of characters (8)

- Response message from slave when normal (SV = 10.0°C).

Idle 3.5 character	Slave address (01H)	Function code (06H)	Data address (0300H)	Data (0064H)	Error check CRC (8865H)	Idle 3.5 character
	1	1	2	2	2	

← No. of characters (8)

- Response message from slave when abnormal (value set outside range)

Idle 3.5 character	Slave address (01H)	Function code (86H)	Error code (03H)	Error check CRC (0261H)	Idle 3.5 character
	1	1	1	2	

← No. of characters (5)

With response messages when an error occurs, "1" is set as the highest bit of the function code (86H). Abnormal code 03H is returned (value set outside range) as response message of error contents.

7. Communication data address

7-1. Details of communication data addresses

(1) Data address and read/write

- In a data address, binary numbers (16-bit data) are expressed by hexadecimal numbers, with 4 bits as a unit.
- R/W/B means that data are capable of being read and written.
- R means that data are only for reading.
- W/B means that data are only for writing.
- If a write-only data address is specified by read command (R), or if a read-only data address is specified by write command (W), a data address error results and abnormal response code is returned.

(2) Data address and the number of data

- If a data address not given in the data addresses for FP93 is specified as the front data address, a data address error results and abnormal response code is returned.
- If the front data address is among the given data addresses and the data address to which the number of data items is added makes it outside the given data addresses, a data number error results and abnormal response code is returned.

(3) Data

- Since data comprise binary numbers (16-bit data) without a decimal point, the form of data, whether there is a decimal point or not, etc., have to be confirmed. (See the instruction manual of the instrument itself.)

Example: How to express data with decimal point

			Hexadecimal data
20.0%	→	200	→ 00C8
99.99	→	9999	→ 270F
-40.00°C	→	-4000	→ F060

- In data of which the unit is UNIT, the position of decimal point depends on the measuring range.
- In other data than the above, binary numbers with code (16-bit data: -32768 to 32767) are used.

Example: How to express 16-bit data

Data with code		Data without code	
Decimal	Hexadecimal	Decimal	Hexadecimal
0	0000	0	0000
1	0001	1	0001
⋮	⋮	⋮	⋮
32767	7FFF	32767	7FFF
-32768	8000	32768	8000
-32767	8001	32769	8001
⋮	⋮	⋮	⋮
-2	FFFE	65534	FFFE
-1	FFFF	65535	FFFF

(4) <Spare> of parameter portion

- When a <spare> portion is read by a read command (R), 0000H data is returned.
- When data is written in a <spare> portion by a write command (W), ordinary response code "0," "0" (30H, 30H) is returned but no change of data is carried out.

(5) Option-related parameters

- If the data address of a parameter not added as an optional item is specified, abnormal response code is returned for both the read command (R) and write command (W).

(6) Parameters not shown in front panel displays owing to action specifications or setting specifications

- Even parameters which are not shown (used) on the front panel displays owing to action specifications or setting specifications are possible to be read and written in communication.

(7) Executing Broadcast

- Broadcast command is usable to all addresses in which a "W" command can be used.

7-2. Communication data address list

Data address (hex)	Parameter	Setting range	R/W/B
0040		Series code 1	R
0041		Series code 2	R
0042		Series code 3	R
0043		Series code 4	R

Unless four series codes from 0x0040 are read at a time, an error code (08) will be returned.

- The address listed above is product ID data area and data are ASCII data, 8 bits as a unit. Therefore, one address represents two data.
- A series code is expressed by 8 data maximum and a surplus area is filled with 00H data.

Example 1: FP93

Address	H	L	H	L
0040	"F"	, "P"	46H	, 50H
0041	"9"	, "3"	39H	, 33H
0042			00H	, 00H
0043			00H	, 00H

0100	PV_W	Measured value	R
0101	SV_W	SV value in execution	R
0102	OUT1_W	Control output value	R
0103	Spare	Fixed to 0000H	R
0104	EXE_FLG	Action flag (bit without action = 0)	R
0105	EV_FLG	Event, DO output flag (without option = 0000H)	R
0106	Spare	Fixed to 0000H	R
0107	EXE_PID	PID No. in execution	R

- Details of EXE_FLG and EV_FLG are as follows:

	D15	D14	D13	D12	D11	D10	D9	D8	D7	D6	D5	D4	D3	D2	D1	D0
EXE_FLG:	0	0	0	0	0	0	AT/W	COM	0	0	0	0	0	0	MAN	AT
EV_FLG:	0	0	0	0	0	0	0	0	0	DO4	DO3	DO2	DO1	EV3	EV2	EV1

- Higher limit side : PV_SO, CJ_SO, b--- = 7FFFH
- Lower limit side : PV_SO, CJ_SO = 8000H

AT/W : AT standby

010B	DI_FLG	DI input state flag	R
------	--------	---------------------	---

- DI_FLG: Details are shown below.

	D15	D14	D13	D12	D11	D10	D9	D8	D7	D6	D5	D4	D3	D2	D1	D0
DI_FLG:	0	0	0	0	0	0	0	0	0	0	0	0	D14	D13	D12	D11

0110	UNIT	Unit of input: 0: "°C" 1: "°F"	R
0111	RANGE	See 8-1. Table of measuring range codes.	R
0112	Spare	Spare	R
0113	DP	0: None, 1: 0.1, 2: 0.01, 3: 0.001	R
0114	SC_L	-1999 to 9989 digit	R
0115	SC_H	-1989 to 9999 digit	R

0120	E_PRG	Program action flag	R
0121	E_PTIN	Pattern No. in execution	R
0122	Spare	Spare	R
0123	E_RPT	The number of patterns executed	R
0124	E_STP	Step number in execution	R
0125	E_TIM	Remaining time of step in execution	R
0126	E_PID	PID No. in execution	R

- E_PRG: Details are shown below.

	D15	D14	D13	D12	D11	D10	D9	D8	D7	D6	D5	D4	D3	D2	D1	D0
E_PRG:	PRG	0	0	0	0	UP	LVL	DW	0	0	0	0	0	GUA	HLD	RUN
PRG	1: PRG,	0: FIX		GUA	1: GUA,	0: NOT GUA										
UP	1: UP,	0: NOT UP		HLD	1: HLD,	0: NOT HLD										
LVL	1: LVL,	0: NOT LVL		RUN	1: RUN,	0: NOT RUN										
DW	1: DW,	0: NOT DW														

- When program is reset (RST), execution data turns to 7FFEh

0182	OUT1_W	Control output set value in manual operation	W/B
0183	Spare	Spare	W/B
0184	AT	0 = Not in execution, 1 = In execution	W/B
0185	MAN	0 = AUTO, 1 = MAN	W/B

018C	COM	0 = LOC, 1 = COM	W/B
------	-----	------------------	-----

0190	RST	0 = RST, 1 = RUN	W/B
0191	HLD	0 = Release of HLD, 1 = HLD	W/B
0192	ADV	0 = No execution, 1 = ADV	W/B

Data address (hex)	Parameter	Setting range	R/W/B
0300	SV1	FIX SV value	R/W/B
030A	SV_L	Set value limiter on lower limit side	R/W/B
030B	SV_H	Set value limiter on higher limit side	R/W/B
0400	PB1	Control output proportional band 1	R/W/B
0401	IT1	Control output integral time 1	R/W/B
0402	DT1	Control output derivative time 1	R/W/B
0403	MR1	Manual reset	R/W/B
0404	DF1	Hysteresis	R/W/B
0405	011_L	Control output lower limit output limiter 1	R/W/B
0406	011_H	Control output higher limit output limiter 1	R/W/B
0407	SF1	Control output target value function 1	R/W/B
0408	PB2	Control output proportional band 2	R/W/B
0409	IT2	Control output integral time 2	R/W/B
040A	DT2	Control output derivative time 2	R/W/B
040B	MR2	Manual reset 2	R/W/B
040C	DF2	Control output hysteresis 2	R/W/B
040D	012_L	Control output lower limit output limiter 2	R/W/B
040E	012_H	Control output higher limit output limiter 2	R/W/B
040F	SF2	Control output target value function 2	R/W/B
0410	PB3	Control output proportional band 3	R/W/B
0411	IT3	Control output integral time 3	R/W/B
0412	DT3	Control output derivative time 3	R/W/B
0413	MR3	Manual reset 3	R/W/B
0414	DF3	Control output hysteresis 3	R/W/B
0415	013_L	Control output lower limit output limiter 3	R/W/B
0416	013_H	Control output higher limit output limiter 3	R/W/B
0417	SF3	Control output target value function 3	R/W/B
0418	PB4	Control output proportional band 4	R/W/B
0419	IT4	Control output integral time 4	R/W/B
041A	DT4	Control output derivative time 4	R/W/B
041B	MR4	Manual reset 4	R/W/B
041C	DF4	Control output hysteresis 4	R/W/B
041D	014_L	Control output lower limit output limiter 4	R/W/B
041E	014_H	Control output higher limit output limiter 4	R/W/B
041F	SF4	Control output target value function 4	R/W/B
0420	PB5	Control output proportional band 5	R/W/B
0421	IT5	Control output integral time 5	R/W/B
0422	DT5	Control output derivative time 5	R/W/B
0423	MR5	Manual reset 5	R/W/B
0424	DF5	Control output hysteresis 5	R/W/B
0425	015_L	Control output lower limit output limiter 5	R/W/B
0426	015_H	Control output higher limit output limiter 5	R/W/B
0427	SF5	Control output target value function 5	R/W/B
0428	PB6	Control output proportional band 6	R/W/B
0429	IT6	Control output integral time 6	R/W/B
042A	DT6	Control output derivative time 6	R/W/B
042B	MR6	Manual reset 6	R/W/B
042C	DF6	Control output hysteresis 6	R/W/B
042D	016_L	Control output lower limit output limiter 6	R/W/B
042E	016_H	Control output higher limit output limiter 6	R/W/B
042F	SF6	Control output target value function 6	R/W/B
04C0	ZSP1	Zone 1 SP	R/W/B
04C1	ZSP2	Zone 2 SP	R/W/B
04C2	ZSP3	Zone 3 SP	R/W/B
04CA	ZHYS	Zone hysteresis	R/W/B
04CB	ZPID	Zone PID (0: OFF, 1: ON)	R/W/B
04DF	DFMD	Hysteresis Mode 0 = CENTER, 1 = SV_OFF, 2 = SV_ON	R/W/B
04FE	STBY	Event output at reset (0: OFF, 1: ON)	R/W/B

Data address (hex)	Parameter	Setting range	R/W/B
0500	EV1_MD	Event 1 mode (See 8-2. Table of EV/DO types.)	R/W/B
0501	EV1_SP	Event 1 set value of FIX (See 8-2. Table of EV/DO types.) Even when event mode is <i>OFF</i> or <i>So</i> , it is possible to change set data through communication but it is initialized when the event mode is changed. (A range allowing writing is -1999 to 9999.)	R/W/B
0502	EV1_DF	Event 1 hysteresis	R/W/B
0503	EV1_STB	Event 1 standby actions 1: Alarm action without standby 2: Alarm action with standby (when power is plied) 3: Alarm action with standby (when power is applied and when SV is changed) 4: Control action without standby	R/W/B
0508	EV2_MD	Event 2 mode (See 8-2. Table of EV/DO types.)	R/W/B
0509	EV2_SP	Event 2 set value of FIX (See 8-2. Table of EV/DO types.) Even when event mode is <i>OFF</i> or <i>So</i> , it is possible to change set data through communication but it is initialized when the event mode is changed. (A range allowing writing is -1999 to 9999.)	R/W/B
050A	EV2_DF	Event 2 hysteresis	R/W/B
050B	EV2_STB	Event 2 standby actions 1: Alarm action without standby 2: Alarm action with standby (upon applying power) 3: Alarm action with standby (upon applying power and changing SV) 4: Control action without standby	R/W/B
0510	EV3_MD	Event 3 mode (See 8-2. Table of EV/DO types.)	R/W/B
0511	EV3_SP	Event 3 set value of FIX (See 8-2. Table of EV/DO types.) Even when event mode is <i>OFF</i> or <i>So</i> , it is possible to change set data through communication but it is initialized when the event mode is changed. (A range allowing writing is -1999 to 9999.)	R/W/B
0512	EV3_DF	Event 3 hysteresis	R/W/B
0513	EV3_STB	Event 3 standby actions 1: Alarm action without standby 2: Alarm action with standby (upon applying power) 3: Alarm action with standby (upon applying power and changing SV) 4: Control action without standby	R/W/B
0518	DO1_MD	DO1 mode (See 8-2. Table of EV/DO types.) (option)	R/W/B
0520	DO2_MD	DO2 mode (See 8-2. Table of EV/DO types.) (option)	R/W/B
0528	DO3_MD	DO3 mode (See 8-2. Table of EV/DO types.) (option)	R/W/B
0530	DO4_MD	DO4 mode (See 8-2. Table of EV/DO types.) (option)	R/W/B
0581	DI2	DI2 (See 8-3. Table of DI types.)	R/W/B
0582	DI3	DI3 (See 8-3. Table of DI types.)	R/W/B
0583	DI4	DI4 (See 8-3. Table of DI types.)	R/W/B
05A0	AO1_MD	Analog output mode: 0 = PV, 1 = SV, 2 = OUT (option)	R/W/B
05A1	AO1_L	Analog output scale lower limit value (option)	R/W/B
05A2	AO1_H	Analog output scale higher limit value (option)	R/W/B
05B0	COM_MEM	Communication memory mode: 0 = EEP, 1 = RAM, 2 = r_E (option)	R/W/B
05B1	COM_KIND	Communication mode type: 0 = COM1, 1 = COM2 (option)	R/W/B
0600	ACTMD	Output characteristic: 0 = RA, 1 = DA	R/W/B
0601	01_CYC	Control output proportional cycle	R/W/B
0611	KLOCK	Keylock: 0 = OFF, Release of keylock 1 = Keylock of screen groups 3, 4 and 5 (except communication mode and special keys on communication speed screen) 2 = Keylock of screen groups 1, 2, 3, 4 and 5 (except communication mode and special keys on communication speed screen) 3 = Keylock of all screens except RUN/RST on basic screen, communication mode and special keys on communication speed screen.	R/W/B

Data address (hex)	Parameter	Setting range	R/W/B
0701	PV_B	PV bias	R/W/B
0702	PV_F	PV filter	R/W/B
071E	RUN_DIMD	RUN/RST DI mode (0:EDG, 1:LVL)	R/W/B
0800	PRG_MD	Program mode (0: PRG, 1: FIX)	R/W/B
0801	Spare	Spare	R/W/B
0802	ST_PTIN	Start pattern No.	R/W/B
0815	PEFIX	FIX shift at program end (0: OFF, 1: ON)	R/W/B
0818	PTN_MOD	Pattern No.	R/W/B
0819	TIM_MOD	Time mode (0: hour/minute, 1: minute/second)	R/W/B
081A	SHT_MOD	With/without power failure compensation (0: OFF, 1:ON)	R/W/B
081B	SCO_MOD	Input abnormality mode (0: HLD, 1: RUN, 2: RST)	R/W/B
0820	FIX_PID No.	FIX PID No.	R/W/B
0882	P01_STP	Pattern No. 01, The number of steps	R/W/B
0883	P01_RPT	Pattern No. 01, The number of pattern executions	R/W/B
0884	P01_ST_SV	Pattern No. 01, Start SV value	R/W/B
0885	P01_GUA_Z	Pattern No. 01, Guarantee Soak Zone (OFF, 1 to 999 digit)	R/W/B
0886	Spare	Spare	R/W/B
0887	P01_PV_ST	Pattern No. 01, PV start	R/W/B
0888	Spare	Spare	R/W/B
0889	P01EV1	Pattern No. 01, EV 1 Level value	R/W/B
088A	P01EV2	Pattern No. 01, EV 2 Level value	R/W/B
088B	P01EV3	Pattern No. 01, EV 3 Level value	R/W/B
088E	P01_TS1STP	Pattern No. 01, Time signal 1, ON/OFF STP No.	R/W/B
088F	P01_TS1_ON	Pattern No. 01, Time signal 1, ON TIME	R/W/B
0890	P01_TS1_OFF	Pattern No. 01, Time signal 1, OFF TIME	R/W/B
0891	P01_TS2STP	Pattern No. 01, Time signal 2, ON/OFF STP No.	R/W/B
0892	P01_TS2_ON	Pattern No. 01, Time signal 2, ON TIME	R/W/B
0893	P01_TS2_OFF	Pattern No. 01, Time signal 2, OFF TIME	R/W/B

• TS1TSP and TS2STP: Details are shown below

D15 D14 D13 D12 D11 D10 D9 D8 D7 D6 D5 D4 D3 D2 D1 D0
 <----- ON STP NO -----> <----- OFF STP NO ----->

08A0	P01_S01_SV	Pattern No. 01, Step No. 01, SV value	R/W/B
08A1	P01_S01_TM	Pattern No. 01, Step No. 01, Step time	R/W/B
08A2	P01_S01_PE	Pattern No. 01, Step No. 01, PID No.	R/W/B
08A3	Spare	Spare	R/W/B
08A4	P01_S02_SV	Pattern No. 01, Step No. 02, SV value	R/W/B
08A5	P01_S02_TM	Pattern No. 01, Step No. 02, Step time	R/W/B
08A6	P01_S02_PE	Pattern No. 01, Step No. 02, PID No.	R/W/B
08A7	Spare	Spare	R/W/B
08A8	P01_S03_SV	Pattern No. 01, Step No. 03, SV value	R/W/B
08A9	P01_S03_TM	Pattern No. 01, Step No. 03, Step time	R/W/B
08AA	P01_S03_PE	Pattern No. 01, Step No. 03, PID No.	R/W/B
08AB	Spare	Spare	R/W/B
08AC	P01_S04_SV	Pattern No. 01, Step No. 04, SV value	R/W/B
08AD	P01_S04_TM	Pattern No. 01, Step No. 04, Step time	R/W/B
08AE	P01_S04_PE	Pattern No. 01, Step No. 04, PID No.	R/W/B
08AF	Spare	Spare	R/W/B
08B0	P01_S05_SV	Pattern No. 01, Step No. 05, SV value	R/W/B
08B1	P01_S05_TM	Pattern No. 01, Step No. 05, Step time	R/W/B
08B2	P01_S05_PE	Pattern No. 01, Step No. 05, PID No.	R/W/B
08B3	Spare	Spare	R/W/B
08B4	P01_S06_SV	Pattern No. 01, Step No. 06, SV value	R/W/B
08B5	P01_S06_TM	Pattern No. 01, Step No. 06, Step time	R/W/B
08B6	P01_S06_PE	Pattern No. 01, Step No. 06, PID No.	R/W/B
08B7	Spare	Spare	R/W/B
08B8	P01_S07_SV	Pattern No. 01, Step No. 07, SV value	R/W/B
08B9	P01_S07_TM	Pattern No. 01, Step No. 07, Step time	R/W/B
08BA	P01_S07_PE	Pattern No. 01, Step No. 07, PID No.	R/W/B
08BB	Spare	Spare	R/W/B
08BC	P01_S08_SV	Pattern No. 01, Step No. 08, SV value	R/W/B
08BD	P01_S08_TM	Pattern No. 01, Step No. 08, Step time	R/W/B
08BE	P01_S08_PE	Pattern No. 01, Step No. 08, PID No.	R/W/B
08BF	Spare	Spare	R/W/B

Data address (hex)	Parameter	Setting range	R/W/B
08C0	P01 S09 SV	Pattern No. 01, Step No. 09, SV value	R/W/B
08C1	P01 S09 TM	Pattern No. 01, Step No. 09, Step time	R/W/B
08C2	P01 S09 PE	Pattern No. 01, Step No. 09, PID No.	R/W/B
08C3	Spare	Spare	R/W/B
08C4	P01 S10 SV	Pattern No. 01, Step No. 10, SV value	R/W/B
08C5	P01 S10 TM	Pattern No. 01, Step No. 10, Step time	R/W/B
08C6	P01 S10 PE	Pattern No. 01, Step No. 10, PID No.	R/W/B
08C7	Spare	Spare	R/W/B
08C8	P01 S11 SV	Pattern No. 01, Step No. 11, SV value	R/W/B
08C9	P01 S11 TM	Pattern No. 01, Step No. 11, Step time	R/W/B
08CA	P01 S11 PE	Pattern No. 01, Step No. 11, PID No.	R/W/B
08CB	Spare	Spare	R/W/B
08CC	P01 S12 SV	Pattern No. 01, Step No. 12, SV value	R/W/B
08CD	P01 S12 TM	Pattern No. 01, Step No. 12, Step time	R/W/B
08CE	P01 S12 PE	Pattern No. 01, Step No. 12, PID No.	R/W/B
08CF	Spare	Spare	R/W/B
08D0	P01 S13 SV	Pattern No. 01, Step No. 13, SV value	R/W/B
08D1	P01 S13 TM	Pattern No. 01, Step No. 13, Step time	R/W/B
08D2	P01 S13 PE	Pattern No. 01, Step No. 13, PID No.	R/W/B
08D3	Spare	Spare	R/W/B
08D4	P01 S14 SV	Pattern No. 01, Step No. 14, SV value	R/W/B
08D5	P01 S14 TM	Pattern No. 01, Step No. 14, Step time	R/W/B
08D6	P01 S14 PE	Pattern No. 01, Step No. 14, PID No.	R/W/B
08D7	Spare	Spare	R/W/B
08D8	P01 S15 SV	Pattern No. 01, Step No. 15, SV value	R/W/B
08D9	P01 S15 TM	Pattern No. 01, Step No. 15, Step time	R/W/B
08DA	P01 S15 PE	Pattern No. 01, Step No. 15, PID No.	R/W/B
08DB	Spare	Spare	R/W/B
08DC	P01 S16 SV	Pattern No. 01, Step No. 16, SV value	R/W/B
08DD	P01 S16 TM	Pattern No. 01, Step No. 16, Step time	R/W/B
08DE	P01 S16 PE	Pattern No. 01, Step No. 16, PID No.	R/W/B

• S**_TM: Details are shown below.

D15 D14 D13 D12 D11 D10 D9 D8 D7 D6 D5 D4 D3 D2 D1 D0
 <----- 0 to 9 * 10 h (m) -----> <----- 0 to 9 * 1 h (m) -----> <----- 0 to 5 * 10 m (s) -----> <----- 0 to 9 * 1 m (s) ----->

0902	P02 STP	Pattern No. 02, The number of steps	R/W/B
0903	P02 RPT	Pattern No. 02, The number of pattern executions	R/W/B
0904	P02 ST SV	Pattern No. 02, Start SV value	R/W/B
0905	P02 GUA Z	Pattern No. 02, Guarantee Soak Zone (OFF, 1 to 999 digit)	R/W/B
0906	Spare	Spare	R/W/B
0907	P02 PV_ST	Pattern No. 02, PV start	R/W/B
0908	Spare	Spare	R/W/B
0909	P02 EV1	Pattern No. 02, EV1 Level value	R/W/B
090A	P02 EV2	Pattern No. 02, EV2 Level value	R/W/B
090B	P02 EV3	Pattern No. 02, EV3 Level value	R/W/B

090E	P02 TS1STP	Pattern No. 02, Time signal 1, ON/OFF STP No.	R/W/B
090F	P02 TS1 ON	Pattern No. 02, Time signal 1, ON TIME	R/W/B
0910	P02 TS1 OFF	Pattern No. 02, Time signal 1, OFF TIME	R/W/B
0911	P02 TS2STP	Pattern No. 02, Time signal 2, ON/OFF STP No.	R/W/B
0912	P02 TS2 ON	Pattern No. 02, Time signal 2, ON TIME	R/W/B
0913	P02 TS2 OFF	Pattern No. 02, Time signal 2, OFF TIME	R/W/B

• TS1STP and TS2STP: Details are shown below.

D15 D14 D13 D12 D11 D10 D9 D8 D7 D6 D5 D4 D3 D2 D1 D0
 <----- ON STP NO -----> <----- OFF STP NO ----->

0920	P02 S01 SV	Pattern No. 02, Step No. 01, SV value	R/W/B
0921	P02 S01 TM	Pattern No. 02, Step No. 01, Step time	R/W/B
0922	P02 S01 PE	Pattern No. 02, Step No. 01, PID No.	R/W/B
0923	Spare	Spare	R/W/B
0924	P02 S02 SV	Pattern No. 02, Step No. 02, SV value	R/W/B
0925	P02 S02 TM	Pattern No. 02, Step No. 02, Step time	R/W/B
0926	P02 S02 PE	Pattern No. 02, Step No. 02, PID No.	R/W/B
0927	Spare	Spare	R/W/B
0928	P02 S03 SV	Pattern No. 02, Step No. 03, SV value	R/W/B
0929	P02 S03 TM	Pattern No. 02, Step No. 03, Step time	R/W/B

Data address (hex)	Parameter	Setting range	R/W
092A	P02 S03 PE	Pattern No. 02, Step No. 03, PID No.	R/W/B
092B	Spare	Spare	R/W/B
092C	P02 S04 SV	Pattern No. 02, Step No. 04, SV value	R/W/B
092D	P02 S04 TM	Pattern No. 02, Step No. 04, Step time	R/W/B
092E	P02 S04 PE	Pattern No. 02, Step No. 04, PID No.	R/W/B
092F	Spare	Spare	R/W/B
0930	P02 S05 SV	Pattern No. 02, Step No. 05, SV value	R/W/B
0931	P02 S05 TM	Pattern No. 02, Step No. 05, Step time	R/W/B
0932	P02 S05 PE	Pattern No. 02, Step No. 05, PID No.	R/W/B
0933	Spare	Spare	R/W/B
0934	P02 S06 SV	Pattern No. 02, Step No. 06, SV value	R/W/B
0935	P02 S06 TM	Pattern No. 02, Step No. 06, Step time	R/W/B
0936	P02 S06 PE	Pattern No. 02, Step No. 06, PID No.	R/W/B
0937	Spare	Spare	R/W/B
0938	P02 S07 SV	Pattern No. 02, Step No. 07, SV value	R/W/B
0939	P02 S07 TM	Pattern No. 02, Step No. 07, Step time	R/W/B
093A	P02 S07 PE	Pattern No. 02, Step No. 07, PID No.	R/W/B
093B	Spare	Spare	R/W/B
093C	P02 S08 SV	Pattern No. 02, Step No. 08, SV value	R/W/B
093D	P02 S08 TM	Pattern No. 02, Step No. 08, Step time	R/W/B
093E	P02 S08 PE	Pattern No. 02, Step No. 08, PID No.	R/W/B
093F	Spare	Spare	R/W/B
0940	P02 S09 SV	Pattern No. 02, Step No. 09, SV value	R/W/B
0941	P02 S09 TM	Pattern No. 02, Step No. 09, Step time	R/W/B
0942	P02 S09 PE	Pattern No. 02, Step No. 09, PID No.	R/W/B
0943	Spare	Spare	R/W/B
0944	P02 S10 SV	Pattern No. 02, Step No. 10, SV value	R/W/B
0945	P02 S10 TM	Pattern No. 02, Step No. 10, Step time	R/W/B
0946	P02 S10 PE	Pattern No. 02, Step No. 10, PID No.	R/W/B
0947	Spare	Spare	R/W/B
0948	P02 S11 SV	Pattern No. 02, Step No. 11, SV value	R/W/B
0949	P02 S11 TM	Pattern No. 02, Step No. 11, Step time	R/W/B
094A	P02 S11 PE	Pattern No. 02, Step No. 11, PID No.	R/W/B
094B	Spare	Spare	R/W/B
094C	P02 S12 SV	Pattern No. 02, Step No. 12, SV value	R/W/B
094D	P02 S12 TM	Pattern No. 02, Step No. 12, Step time	R/W/B
094E	P02 S12 PE	Pattern No. 02, Step No. 12, PID No.	R/W/B
094F	Spare	Spare	R/W/B
0950	P02 S13 SV	Pattern No. 02, Step No. 13, SV value	R/W/B
0951	P02 S13 TM	Pattern No. 02, Step No. 13, Step time	R/W/B
0952	P02 S13 PE	Pattern No. 02, Step No. 13, PID No.	R/W/B
0953	Spare	Spare	R/W/B
0954	P02 S14 SV	Pattern No. 02, Step No. 14, SV value	R/W/B
0955	P02 S14 TM	Pattern No. 02, Step No. 14, Step time	R/W/B
0956	P02 S14 PE	Pattern No. 02, Step No. 14, PID No.	R/W/B
0957	Spare	Spare	R/W/B
0958	P02 S15 SV	Pattern No. 02, Step No. 15, SV value	R/W/B
0959	P02 S15 TM	Pattern No. 02, Step No. 15, Step time	R/W/B
095A	P02 S15 PE	Pattern No. 02, Step No. 15, PID No.	R/W/B
095B	Spare	Spare	R/W/B
095C	P02 S16 SV	Pattern No. 02, Step No. 16, SV value	R/W/B
095D	P02 S16 TM	Pattern No. 02, Step No. 16, Step time	R/W/B
095E	P02 S16 PE	Pattern No. 02, Step No. 16, PID No.	R/W/B

- S**_TM: Details are shown below.

D15 D14 D13 D12 D11 D10 D9 D8 D7 D6 D5 D4 D3 D2 D1 D0
 <----- 0 to 9 * 10 h (m) -----> <----- 0 to 9 * 1 h (m) -----> <----- 0 to 5 * 10 m (s) -----> <----- 0 to 9 * 1 m (s) ----->

- Supplementary explanation of Pattern No. 02, Step No. 01 to Step No. 16:
 Note that information has different meaning by the number of patterns.

The number of patterns	Maximum number of steps of each pattern	Meaning of Pattern No. 02 Step No. 01 to Step No. 16 information
1	64	Information of Step No. 17 to Step No. 32 of Pattern 1
2	32	Information of Step No. 17 to Step No. 32 of Pattern 1
4	16	Information of Step No. 01 to Step No. 16 of Pattern 2

Data address (hex)	Parameter	Setting range	R/W
0982	P03 STP	Pattern No. 03, The number of steps	R/W/B
0983	P03 RPT	Pattern No. 03, The number of pattern executions	R/W/B
0984	P03 ST SV	Pattern No. 03, Start SV value	R/W/B
0985	P03 GUA Z	Pattern No. 03, Guarantee Soak Zone (OFF, 1 to 999 digit)	R/W/B
0986	Spare	Spare	R/W/B
0987	P03 PV ST	Pattern No. 03, PV start	R/W/B
0988	Spare	Spare	R/W/B
0989	P03 EV1	Pattern No. 03, EV1 Level value	R/W/B
098A	P03 EV2	Pattern No. 03, EV2 Level value	R/W/B
098B	P03 EV3	Pattern No. 03, EV3 Level value	R/W/B

098E	P03 TS1STP	Pattern No. 03, Time signal 1, ON/OFF STP No.	R/W/B
098F	P03 TS1 ON	Pattern No. 03, Time signal 1, ON TIME	R/W/B
0990	P03 TS1 OFF	Pattern No. 03, Time signal 1, OFF TIME	R/W/B
0991	P03 TS2STP	Pattern No. 03, Time signal 2, ON/OFF STP No.	R/W/B
0992	P03 TS2 ON	Pattern No. 03, Time signal 2, ON TIME	R/W/B
0993	P03 TS2 OFF	Pattern No. 03, Time signal 2, OFF TIME	R/W/B

• TS1STP and TS2STP: Details are shown below.

D15 D14 D13 D12 D11 D10 D9 D8 D7 D6 D5 D4 D3 D2 D1 D0
 <----- ON STP NO -----> <----- OFF STP NO ----->

09A0	P03 S01 SV	Pattern No. 03, Step No. 01, SV value	R/W/B
09A1	P03 S01 TM	Pattern No. 03, Step No. 01, Step time	R/W/B
09A2	P03 S01 PE	Pattern No. 03, Step No. 01, PID No.	R/W/B
09A3	Spare	Spare	R/W/B
09A4	P03 S02 SV	Pattern No. 03, Step No. 02, SV value	R/W/B
09A5	P03 S02 TM	Pattern No. 03, Step No. 02, Step time	R/W/B
09A6	P03 S02 PE	Pattern No. 03, Step No. 02, PID No.	R/W/B
09A7	Spare	Spare	R/W/B
09A8	P03 S03 SV	Pattern No. 03, Step No. 03, SV value	R/W/B
09A9	P03 S03 TM	Pattern No. 03, Step No. 03, Step time	R/W/B
09AA	P03 S03 PE	Pattern No. 03, Step No. 03, PID No.	R/W/B
09AB	Spare	Spare	R/W/B
09AC	P03 S04 SV	Pattern No. 03, Step No. 04, SV value	R/W/B
09AD	P03 S04 TM	Pattern No. 03, Step No. 04, Step time	R/W/B
09AE	P03 S04 PE	Pattern No. 03, Step No. 04, PID No.	R/W/B
09AF	Spare	Spare	R/W/B
09B0	P03 S05 SV	Pattern No. 03, Step No. 05, SV value	R/W/B
09B1	P03 S05 TM	Pattern No. 03, Step No. 05, Step time	R/W/B
09B2	P03 S05 PE	Pattern No. 03, Step No. 05, PID No.	R/W/B
09B3	Spare	Spare	R/W/B
09B4	P03 S06 SV	Pattern No. 03, Step No. 06, SV value	R/W/B
09B5	P03 S06 TM	Pattern No. 03, Step No. 06, Step time	R/W/B
09B6	P03 S06 PE	Pattern No. 03, Step No. 06, PID No.	R/W/B
09B7	Spare	Spare	R/W/B
09B8	P03 S07 SV	Pattern No. 03, Step No. 07, SV value	R/W/B
09B9	P03 S07 TM	Pattern No. 03, Step No. 07, Step time	R/W/B
09BA	P03 S07 PE	Pattern No. 03, Step No. 07, PID No.	R/W/B
09BB	Spare	Spare	R/W/B
09BC	P03 S08 SV	Pattern No. 03, Step No. 08, SV value	R/W/B
09BD	P03 S08 TM	Pattern No. 03, Step No. 08, Step time	R/W/B
09BE	P03 S08 PE	Pattern No. 03, Step No. 08, PID No.	R/W/B
09BF	Spare	Spare	R/W/B
09C0	P03 S09 SV	Pattern No. 03, Step No. 09, SV value	R/W/B
09C1	P03 S09 TM	Pattern No. 03, Step No. 09, Step time	R/W/B
09C2	P03 S09 PE	Pattern No. 03, Step No. 09, PID No.	R/W/B
09C3	Spare	Spare	R/W/B
09C4	P03 S10 SV	Pattern No. 03, Step No. 10, SV value	R/W/B
09C5	P03 S10 TM	Pattern No. 03, Step No. 10, Step time	R/W/B
09C6	P03 S10 PE	Pattern No. 03, Step No. 10, PID No.	R/W/B
09C7	Spare	Spare	R/W/B
09C8	P03 S11 SV	Pattern No. 03, Step No. 11, SV value	R/W/B
09C9	P03 S11 TM	Pattern No. 03, Step No. 11, Step time	R/W/B
09CA	P03 S11 PE	Pattern No. 03, Step No. 11, PID No.	R/W/B
09CB	Spare	Spare	R/W/B
09CC	P03 S12 SV	Pattern No. 03, Step No. 12, SV value	R/W/B
09CD	P03 S12 TM	Pattern No. 03, Step No. 12, Step time	R/W/B
09CE	P03 S12 PE	Pattern No. 03, Step No. 12, PID No.	R/W/B
09CF	Spare	Spare	R/W/B

Data address (hex)	Parameter	Setting range	R/W/B
09D0	P03 S13 SV	Pattern No. 03, Step No. 13, SV value	R/W/B
09D1	P03 S13 TM	Pattern No. 03, Step No. 13, Step time	R/W/B
09D2	P03 S13 PE	Pattern No. 03, Step No. 13, PID No.	R/W/B
09D3	Spare	Spare	R/W/B
09D4	P03 S14 SV	Pattern No. 03, Step No. 14, SV value	R/W/B
09D5	P03 S14 TM	Pattern No. 03, Step No. 14, Step time	R/W/B
09D6	P03 S14 PE	Pattern No. 03, Step No. 14, PID No.	R/W/B
09D7	Spare	Spare	R/W/B
09D8	P03 S15 SV	Pattern No. 03, Step No. 15, SV value	R/W/B
09D9	P03 S15 TM	Pattern No. 03, Step No. 15, Step time	R/W/B
09DA	P03 S15 PE	Pattern No. 03, Step No. 15, PID No.	R/W/B
09DB	Spare	Spare	R/W/B
09DC	P03 S16 SV	Pattern No. 03, Step No. 16, SV value	R/W/B
09DD	P03 S16 TM	Pattern No. 03, Step No. 16, Step time	R/W/B
09DE	P03 S16 PE	Pattern No. 03, Step No. 16, PID No.	R/W/B

• S**_TM: Details are shown below.

D15 D14 D13 D12 D11 D10 D9 D8 D7 D6 D5 D4 D3 D2 D1 D0
 <----- 0 to 9 * 10 h (m) -----> <----- 0 to 9 * 1 h (m) -----> <----- 0 to 5 * 10 m (s) -----> <----- 0 to 9 * 1 m (s) ----->

• Supplementary explanation of Pattern No. 03, Step No. 01 to Step No. 16:
 Note that information has different meaning by the number of patterns.

The number of patterns	Maximum number of steps of each pattern	Meaning of Pattern No. 03 Step No. 01 to Step No. 16 information
1	64	Information of Step No. 33 to Step No. 48 of Pattern 1
2	32	Information of Step No. 01 to Step No. 16 of Pattern 2
4	16	Information of Step No. 01 to Step No. 16 of Pattern 3

0A02	P04 STP	Pattern No. 04, The number of steps	R/W/B
0A03	P04 RPT	Pattern No. 04, The number of pattern executions	R/W/B
0A04	P04 ST SV	Pattern No. 04, Start SV value	R/W/B
0A05	P04 GUA Z	Pattern No. 04, Guarantee Soak Zone (OFF, 1 to 999 digit)	R/W/B
0A06	Spare	Spare	R/W/B
0A07	P04 PV ST	Pattern No. 04, PV start	R/W/B
0A08	Spare	Spare	R/W/B
0A09	P04 EV1	Pattern No. 04, EV1 Level value	R/W/B
0A0A	P04 EV2	Pattern No. 04, EV2 Level value	R/W/B
0A0B	P04 EV3	Pattern No. 04, EV3 Level value	R/W/B

0A0E	P04 TS1STP	Pattern No. 04, Time signal 1, ON/OFF STP No.	R/W/B
0A0F	P04 TS1_ON	Pattern No. 04, Time signal 1, ON TIME	R/W/B
0A10	P04 TS1_OFF	Pattern No. 04, Time signal 1, OFF TIME	R/W/B
0A11	P04 TS2STP	Pattern No. 04, Time signal 2, ON/OFF STP No.	R/W/B
0A12	P04 TS2_ON	Pattern No. 04, Time signal 2, ON TIME	R/W/B
0A13	P04 TS2_OFF	Pattern No. 04, Time signal 2, OFF TIME	R/W/B

• TS1STP and TS2STP: Details are shown below.

D15 D14 D13 D12 D11 D10 D9 D8 D7 D6 D5 D4 D3 D2 D1 D0
 <----- ON STP NO -----> <----- OFF STP NO ----->

0A20	P04 S01 SV	Pattern No. 04, Step No. 01, SV value	R/W/B
0A21	P04 S01 TM	Pattern No. 04, Step No. 01, Step time	R/W/B
0A22	P04 S01 PE	Pattern No. 04, Step No. 01, PID No.	R/W/B
0A23	Spare	Spare	R/W/B
0A24	P04 S02 SV	Pattern No. 04, Step No. 02, SV value	R/W/B
0A25	P04 S02 TM	Pattern No. 04, Step No. 02, Step time	R/W/B
0A26	P04 S02 PE	Pattern No. 04, Step No. 02, PID No.	R/W/B
0A27	Spare	Spare	R/W/B
0A28	P04 S03 SV	Pattern No. 04, Step No. 03, SV value	R/W/B
0A29	P04 S03 TM	Pattern No. 04, Step No. 03, Step time	R/W/B
0A2A	P04 S03 PE	Pattern No. 04, Step No. 03, PID No.	R/W/B
0A2B	Spare	Spare	R/W/B
0A2C	P04 S04 SV	Pattern No. 04, Step No. 04, SV value	R/W/B
0A2D	P04 S04 TM	Pattern No. 04, Step No. 04, Step time	R/W/B
0A2E	P04 S04 PE	Pattern No. 04, Step No. 04, PID No.	R/W/B
0A2F	Spare	Spare	R/W/B
0A30	P04 S05 SV	Pattern No. 04, Step No. 05, SV value	R/W/B
0A31	P04 S05 TM	Pattern No. 04, Step No. 05, Step time	R/W/B
0A32	P04 S05 PE	Pattern No. 04, Step No. 05, PID No.	R/W/B
0A33	Spare	Spare	R/W/B

Data address (hex)	Parameter	Setting range	R/W
0A34	P04 S06_SV	Pattern No. 04, Step No. 06, SV value	R/W/B
0A35	P04 S06_TM	Pattern No. 04, Step No. 06, Step time	R/W/B
0A36	P04 S06_PE	Pattern No. 04, Step No. 06, PID No.	R/W/B
0A37	Spare	Spare	R/W/B
0A38	P04 S07_SV	Pattern No. 04, Step No. 07, SV value	R/W/B
0A39	P04 S07_TM	Pattern No. 04, Step No. 07, Step time	R/W/B
0A3A	P04 S07_PE	Pattern No. 04, Step No. 07, PID No.	R/W/B
0A3B	Spare	Spare	R/W/B
0A3C	P04 S08_SV	Pattern No. 04, Step No. 08, SV value	R/W/B
0A3D	P04 S08_TM	Pattern No. 04, Step No. 08, Step time	R/W/B
0A3E	P04 S08_PE	Pattern No. 04, Step No. 08, PID No.	R/W/B
0A3F	Spare	Spare	R/W/B
0A40	P04 S09_SV	Pattern No. 04, Step No. 09, SV value	R/W/B
0A41	P04 S09_TM	Pattern No. 04, Step No. 09, Step time	R/W/B
0A42	P04 S09_PE	Pattern No. 04, Step No. 09, PID No.	R/W/B
0A43	Spare	Spare	R/W/B
0A44	P04 S10_SV	Pattern No. 04, Step No. 10, SV value	R/W/B
0A45	P04 S10_TM	Pattern No. 04, Step No. 10, Step time	R/W/B
0A46	P04 S10_PE	Pattern No. 04, Step No. 10, PID No.	R/W/B
0A47	Spare	Spare	R/W/B
0A48	P04 S11_SV	Pattern No. 04, Step No. 11, SV value	R/W/B
0A49	P04 S11_TM	Pattern No. 04, Step No. 11, Step time	R/W/B
0A4A	P04 S11_PE	Pattern No. 04, Step No. 11, PID No.	R/W/B
0A4B	Spare	Spare	R/W/B
0A4C	P04 S12_SV	Pattern No. 04, Step No. 12, SV value	R/W/B
0A4D	P04 S12_TM	Pattern No. 04, Step No. 12, Step time	R/W/B
0A4E	P04 S12_PE	Pattern No. 04, Step No. 12, PID No.	R/W/B
0A4F	Spare	Spare	R/W/B
0A50	P04 S13_SV	Pattern No. 04, Step No. 13, SV value	R/W/B
0A51	P04 S13_TM	Pattern No. 04, Step No. 13, Step time	R/W/B
0A52	P04 S13_PE	Pattern No. 04, Step No. 13, PID No.	R/W/B
0A53	Spare	Spare	R/W/B
0A54	P04 S14_SV	Pattern No. 04, Step No. 14, SV value	R/W/B
0A55	P04 S14_TM	Pattern No. 04, Step No. 14, Step time	R/W/B
0A56	P04 S14_PE	Pattern No. 04, Step No. 14, PID No.	R/W/B
0A57	Spare	Spare	R/W/B
0A58	P04 S15_SV	Pattern No. 04, Step No. 15, SV value	R/W/B
0A59	P04 S15_TM	Pattern No. 04, Step No. 15, Step time	R/W/B
0A5A	P04 S15_PE	Pattern No. 04, Step No. 15, PID No.	R/W/B
0A5B	Spare	Spare	R/W/B
0A5C	P04 S16_SV	Pattern No. 04, Step No. 16, SV value	R/W/B
0A5D	P04 S16_TM	Pattern No. 04, Step No. 16, Step time	R/W/B
0A5E	P04 S16_PE	Pattern No. 04, Step No. 16, PID No.	R/W/B

• S**_TM: Details are shown below.

D15 D14 D13 D12 D11 D10 D9 D8 D7 D6 D5 D4 D3 D2 D1 D0
 <----- 0 to 9 * 10 h (m) -----> <----- 0 to 9 * 1 h (m) -----> <----- 0 to 5 * 10 m (s) -----> <----- 0 to 9 * 1 m (s) ----->

• Supplementary explanation of Pattern No. 04, Step No. 01 to Step No. 16:

Note that information has different meaning by the number of patterns.

The number of patterns	Maximum number of steps of each pattern	Meaning of Pattern No. 04 Step No. 01 to Step No. 16 information
1	64	Information of Step No. 49 to Step No. 64 of Pattern 1
2	32	Information of Step No. 17 to Step No. 32 of Pattern 2
4	16	Information of Step No. 01 to Step No. 16 of Pattern 4

8. Supplementary explanation

8-1. Table of measuring range codes

Input	Code	Type of Input	Measuring range (°C)	Measuring range (°F)	
Multi-input	Thermocouple	01	B *1	0 to 1800	0 to 3300
		02	R	0 to 1700	0 to 3100
		03	S	0 to 1700	0 to 3100
		04 *2	K	-199.9 to 400.0	-300 to 750
		05	K	0.0 to 800.0	0 to 1500
		06	K	0 to 1200	0 to 2200
		07	E	0 to 700	0 to 1300
		08	J	0 to 600	0 to 1100
		09 *2	T	-199.9 to 200.0	-300 to 400
		10	N	0 to 1300	0 to 2300
		11	PLII *3	0 to 1300	0 to 2300
		12	C(WRe5-26)	0 to 2300	0 to 4200
		13 *2	U *4	-199.9 to 200.0	-300 to 400
		14	L *4	0 to 600	0 to 1100
Multi-input	R.T.D.	31	Pt100	-200 to 600	-300 to 1100
		32	Pt100	-100.0 to 100.0	-150.0 to 200.0
		33	Pt100	-50.0 to 50.0	-50.0 to 120.0
		34	Pt100	0.0 to 200.0	0.0 to 400.0
		35	Jpt100	-200 to 500	-300 to 1000
		36	Jpt100	-100.0 to 100.0	-150.0 to 200.0
		37	Jpt100	-50.0 to 50.0	-50.0 to 120.0
		38	Jpt100	0.0 to 200.0	0.0 to 400.0
Multi-input	mV	71	-10 to 10 mV	Owing to scaling function, any measuring range can be set within the following range. Initial value: 0.0 to 100.0 Input scaling setting range : -1999 to 9999 digit Span : 10 to 5000 digit Position of decimal point : None 1, 2 or 3 decimal places Lower limit value < higher limit value	
		72	0 to 10 mV		
		73	0 to 20 mV		
		74	0 to 50 mV		
		75	10 to 50 mV		
		76	0 to 100 mV		
Multi-input	V	81	-1 to 1 V		
		82	0 to 1 V		
		83	0 to 2 V		
		84	0 to 5 V		
		85	1 to 5 V		
		86	0 to 0 V		
Current	mA	91	0 to 20 mA		
		92	4 to 20 mA		

Thermocouple B, R, S, K, E, J, T, N, C(WRe5-26): JIS/IEC

R.T.D Pt100: JIS/IEC; JPt100: JIS

*1 Thermocouple B: Accuracy guarantee not applicable to 400°C or 750°F and below.

*2 Thermocouple K, T, U: Accuracy of those whose readings are below -100°C is $\pm(0.7\% \text{ FS} + 1 \text{ digit})$.

*3 Thermocouple PLII: Platinel

*4 Thermocouple U, L: DIN 43710

When not designated, factory-set measuring range is K thermocouple (0.0–800.0°C).

8-2. Table of EV/DO types

EV/DO code	Event type	Value	Initial value	Setting range	EV/DO
<i>non</i>	None	0	-----	-----	EV/DO
<i>Hd</i>	Higher limit deviation	1	2000 digit	-1999 to 2000 digit	EV
<i>Ld</i>	Lower limit deviation	2	-1999 digit	-1999 to 2000 digit	EV
<i>od</i>	Outside higher/lower limit deviations	3	2000 digit	0 to 2000 digit	EV
<i>id</i>	Within higher/lower limit deviations	4	2000 digit	0 to 2000 digit	EV
<i>HR</i>	Higher limit absolute value	5	Higher limit of measuring range	Within measuring range	EV
<i>LR</i>	Higher limit absolute value	6	Lower limit of measuring range	Within measuring range	EV
<i>So</i>	Scaleover	7	EV/DO is continuously output during scaleover.		EV/DO
<i>Hold</i>	Hold	8	EV/DO is continuously output during HOLD.		EV/DO
<i>GUR</i>	Guarantee soak	9	EV/DO is continuously output during guarantee soak.		EV/DO
<i>tNS1</i>	Time signal 1	10	EV/DO is continuously output while time signal 1 is output.		EV/DO
<i>tNS2</i>	Time signal 2	11	EV/DO is continuously output while time signal 2 is output.		EV/DO
<i>run</i>	RUN status	12	EV/DO is continuously output while RUN is in execution.		EV/DO
<i>StPS</i>	Step signal	13	EV/DO is output when step signal is output.		EV/DO
<i>EndS</i>	End signal	14	EV/DO is output when end signal is output.		EV/DO
<i>Fix</i>	FIX	15	EV/DO is continuously output during FIX.		EV/DO

8-3. Table of DI types

DI code	Event type	Value	Sense	Setting range
<i>non</i>	None	0	-----	-----
<i>Hold</i>	Hold	1	Level	Hold when DI turns ON.
<i>Adv</i>	Advance	2	Edge	Advance when DI turns ON.
<i>Fix</i>	FIX level	3	Level	FIX action when DI turns ON.
<i>StP2</i>	Start pattern No. 2 bits	4	Level	Level Start pattern No. is specified by 2 bits by using 2 DIs. Setting possible only by DI3.
<i>StP3</i>	Start pattern No. 3 bits	5	Level	Start pattern No. is specified by 3 bits by using 3 DIs. Setting possible only by DI3.

9. ASCII code list

	b7b6b5	000	001	010	011	100	101	110	111
b4 to b1		0	1	2	3	4	5	6	7
0000	0	NUL	TC7 (DLE)	SP	0	@	P	`	p
0001	1	TC1 (SOH)	DC1	!	1	A	Q	a	q
0010	2	TC2 (STX)	DC2	,,	2	B	R	b	r
0011	3	TC3 (ETX)	DC3	#	3	C	S	c	s
0100	4	TC4 (EOT)	DC4	\$	4	D	T	d	t
0101	5	TC5 (ENQ)	TC8 (NAK)	%	5	E	U	e	u
0110	6	TC6 (ACK)	TC9 (SYN)	&	6	F	V	f	v
0111	7	BEL	TC10 (ETB)	,	7	G	W	g	w
1000	8	FE0 (BS)	CAN	(8	H	X	h	x
1001	9	FE1 (HT)	EM)	9	I	Y	i	y
1010	A	FE2 (LF)	SUB	*	:	J	Z	j	z
1011	B	FE3 (VT)	ESC	+	;	K	[k	{
1100	C	FE4 (FF)	IS4 (FS)	,	<	L	\	l	
1101	D	FE5 (CR)	IS3 (GS)	_	=	M]	m	}
1110	E	SO	IS2 (RS)	.	>	N	^	n	~
1111	F	SI	IS1 (US)	/	?	O	_	o	DEL

The contents of this instruction manual are subject to change without notice for improvement.

Temperature and Humidity Control Specialists
SHIMADEN CO., LTD.

Head Office: 2-30-10 Kitamachi, Nerima-Ku, Tokyo 179-0081 Japan

Phone: +81-3-3931-7891 Fax: +81-3-3931-3089

E-MAIL: exp-dept@shimaden.co.jp URL: <https://www.shimaden.co.jp>

PRINTED IN JAPAN