

# How to Change the Chart Speed

## - SR102 Series Chart Recorder -

### Step 1: Removing the transport screw

The inner unit is fixed by a transport screw. To change the chart speed, the inner unit has to be unfix. Therefore, remove the transport screw as illustrated below.

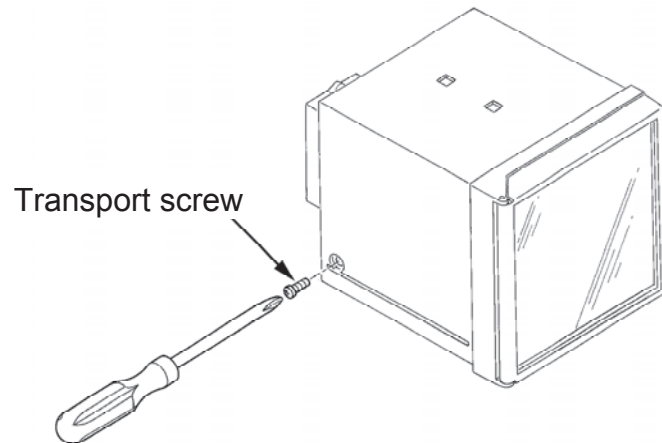

### Step 2: Turning the power off

Open the front door and turn off the power switch which is located at the lower right.

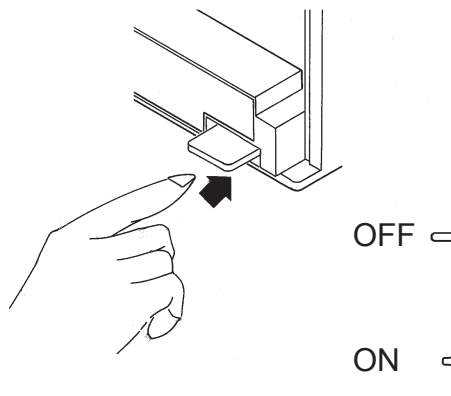

Step 3: Pulling out the inner unit

Pull out the inner unit while pressing down the metal lock lever located at the lower right of the inner unit.

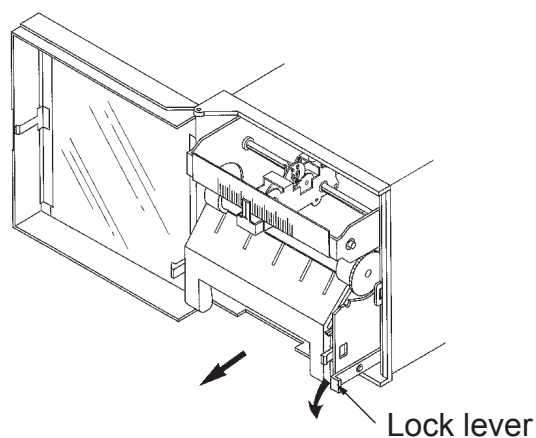

Step 4: Removing the chart cassette

Remove the chart cassette from the main unit while lightly pressing the stoppers located at the right and left sides of the chart cassette.

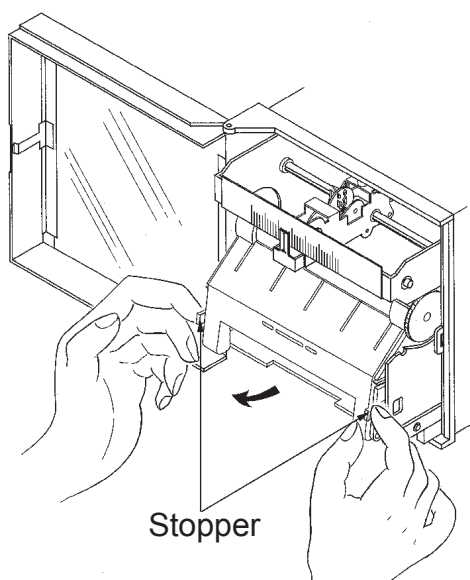

Step 5: Removing the lock screw

Remove the fall prevention lock screw for the inner unit.

Then, pull the inner unit so that the inner unit can be taken out completely.

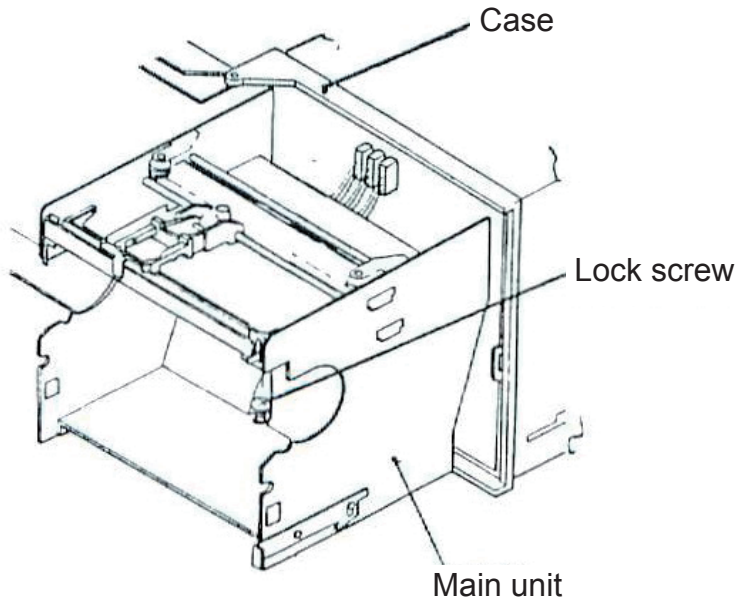

Step 6: Replacing the chart (paper feeding gears)

The gears are mounted on the left side of the inner unit as illustrated below.

Replace the gears fixed on the upper side of the inner unit and try different gear combinations to change the chart speed (three combinations in total).

These gears can be removed by hand.

